



EV SERIES 50 HZ

VERTICAL MULTISTAGE PUMPS



INDEX

VERTICAL MULTISTAGE PUMPS	2
Family curves.....	3
Pump identification code.....	3
TABLES OF HYDRAULIC PERFORMANCE AT 50 HZ	4
EV 1-3.....	4
EV 6-10.....	5
EV 15-20.....	6
EV 30-45.....	7
EV 65-95.....	8
SPARE PARTS AND MATERIALS	9
EV 1/.../A - 3/.../A - 6/.../A - 10/.../A.....	10
EV 15/.../A - 20/.../A	12
EV 30-45-65-95	14
MOTORS AEG.....	16
Motors spare parts.....	18
MECHANICAL SEAL SPECIFICATIONS	19
COMPATIBILITY OF FLUIDS AND MATERIALS.....	20
PERFORMANCE CURVES AND TECHNICAL DATA	21
EV 1.....	23
EV 3.....	29
EV 6.....	35
EV 10.....	41
EV 15.....	47
EV 20.....	51
EV 30.....	55
EV 45.....	61
EV 65.....	65
EV 95.....	69
DIMENSIONS OF COUNTERFLANGES	72

NOTE: Franklin Electric S.r.l. reserves the right to amend specification without prior notice
 For the most up-to-date product information, visit franklinwater.eu.

VERTICAL MULTISTAGE PUMPS

APPLICATIONS

- Boiler feed
- Circulation of hot and cold water for heating, cooling and conditioning systems
- Handling of water, free of suspended solids, in the civil, industrial and agricultural sector
- Irrigation systems
- Pressure boosting and water supply systems
- Wash down unit
- Water treatment plants

FEATURES

- All wetted parts in stainless steel (Inox version)
- Compact and solid structure
- Diffuser bushing made of graphite for durability against dry running (EV 30-45-65-95)
- Easy disassembly without any special tool
- Easy installation in-line ports
- Stainless steel impeller and diffuser for corrosion resistance
- Oversize ball bearing (bearing bracket) ensures motor-bearing long life and eliminates axial and other adjustments of moving parts
- WRAS certified PPS (EV 1-3-6-10-15-20) / PTFE (EV 30-45-65-95)
- Easy to replace floating neck rings guarantee long-lasting performance
- Removal of the mechanical seal without disassembling the pump; for models higher than 4 kW no need to dismantle the motor
- Replaceable stainless steel wear ring in the neck of the impeller
- Shaft bearing and journal sleeve made of tungsten carbide
- Standard mechanical seal (EN 12756 ex DIN 24960) WRAS certified; balanced version for EV 30-45-65-95
- Standard IE3 motor without oversize bearing, size B14 up to 4 kW / size B5 from 5.5 kW and above
- Tungsten carbide intermediate bearing to control and eliminate vibration and stabilize the rotor with a large number of stages

SPECIFICATIONS

- Flow: up to 120 m³/h at 50 Hz
- Head: up to 320 m at 50 Hz
- Direction of rotation: clockwise looking at the pump from the top
- Discharge and Suction port: Oval, Round flanges, Victaulic and Clamp connections
- Hydraulic characteristics are guaranteed, according to ISO Standard 9906:2012, grade 3B
- Liquid temperature range: from -15 °C to +120 °C
- Materials: suitable for handling potable water (materials approved according to WRAS, ACS)
- Maximum working pressure: Oval flange 16 Bar; Round Flange, Victaulic and Clamp connections 25 bar
- Motor powers from 0.37 to 45 kW at 50 Hz
- AISI 304 Standard for models EV 1-3-6-10-15-20

AVAILABLE ON REQUEST

- AISI 304 version for models EV 30-45-65-95
- Special materials for the mechanical seal, gaskets and elastomers
- Balanced mechanical seal EN 12756 for EV 1-3-6-10-15-20
- Oval counter flanges (EV 1-3-6-10-15-20)
- Round counter flanges

FAMILY CURVES

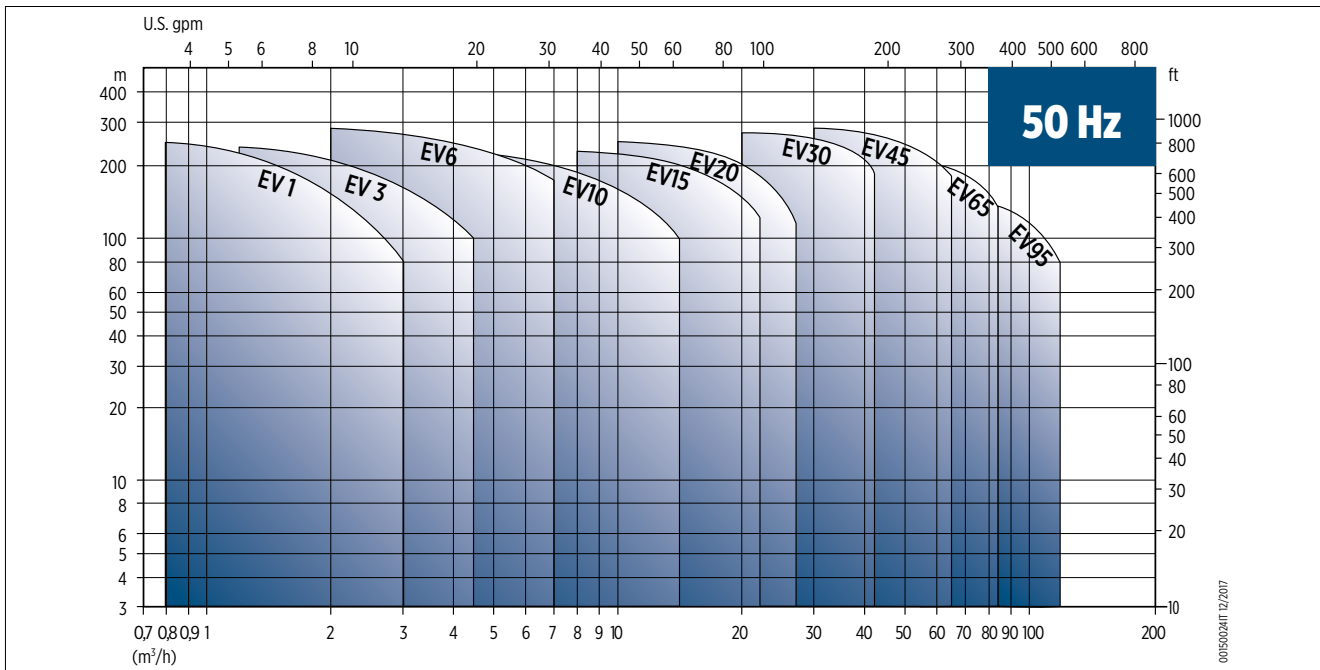

PUMP IDENTIFICATION CODE

EV 30 / 15 F G 015 E1

- If empty: pump without motor "IE..": motor efficiency class
- If empty: Std. version
- If empty: Std. version, "P": Passivated
- If empty: Std. version, "H": High pressure
- Type of mechanical seal and O-ring
- Mechanical seal: if empty: Std., "B": balanced
- Type of motor: if empty: "without motor", "T": three-phase, "M": single-phase
- No. of poles in motor: if empty: "2 poles", "4": 4 poles
- Frequency: if empty: 50 Hz; "6": 60 Hz
- Motor power: (kW x 10)
- Material: "G": cast iron/Inox; "I": AISI304 (EN 1.4301); "N": AISI316 (EN 1.4401)
- Flanges: "F": round; "T": oval; "V": Victaulic; "C": clamp
- Number of trimmed impellers, if empty: none
- Number of stages/impellers
- Nominal flow in m³/h
- Pump model

Version	Pump body/Hydraulics	EV 1	EV 3	EV 6	EV 10	EV 15	EV 20	EV 30	EV 45	EV 65	EV 95
I	AISI 304 / AISI 304	●	●	●	●	●	●	○	○	○	○
G	CAST IRON / AISI 304							●	●	●	●
N	AISI 316 / AISI 316	●	●	●	●	●	●	●	●	●	●

● = Std. version ○ = Available on request

Flange models	Maximum working pressure [bar]									
	EV 1	EV 3	EV 6	EV 10	EV 15	EV 20	EV 30	EV 45	EV 65	EV 95
T version	16	16	16	16	16	16				
F (PN25), V and C version	26	26	26	26	26	26				
F version (PN16)							16	16	16	16
F version (PN25/40)							40	40	25	25
Maximum inlet pressure (HT)	refer to the tables of hydraulic performance									

The Inlet pressure of the pump plus the pressure inside the pump must not exceed the maximum working pressure

TABLES OF HYDRAULIC PERFORMANCE AT 50 HZ

EV 1-3

Pump model	RATED POWER		Q = DELIVERY										
			H1	l/min 0	8.3	16.7	25.0	33.3	42	50.0	58.3	67	75.0
	[kW]	[HP]	Bar	m ³ /h 0	0.5	1	1.5	2	2.5	3	3.5	4	4.5
H = TOTAL HEAD - METERS COLUMN OF WATER [m]													
EV 1/2	0.37	0.5	20	14.5	13.5	12.5	11.5	9.5	7.5				
EV 1/3	0.37	0.5	20	21.5	20	19	17	14	11				
EV 1/4	0.37	0.5	20	28	26.5	24.5	22	18.5	14				
EV 1/5	0.37	0.5	20	35	33	30.5	27	22.5	17				
EV 1/6	0.37	0.5	20	41.5	39	36	32	26.5	19.5				
EV 1/7	0.37	0.5	20	48	45	41.5	36.5	30	22				
EV 1/8	0.55	0.75	20	55	52	48	42.5	35	26				
EV 1/9	0.55	0.75	20	61.5	58	53	47	39	28.5				
EV 1/10	0.55	0.75	20	68	64	58.5	51.5	43	31.5				
EV 1/11	0.55	0.75	20	74.5	69.5	64	56.5	46.5	34				
EV 1/12	0.75	1	20	83	78.5	72	64	53	39.5				
EV 1/13	0.75	1	20	89.5	84.5	77.5	68.5	57	42				
EV 1/14	0.75	1	20	96	90.5	83	73	60.5	44.5				
EV 1/15	0.75	1	20	102.5	96	88	78	64	47				
EV 1/17	1.1	1.5	20	118	111.5	103	91.5	76	56.5				
EV 1/19	1.1	1.5	20	131	123.5	114	101	84	62				
EV 1/22	1.1	1.5	20	150.5	141.5	130	115	95	69.5				
EV 1/23	1.5	2	20	160.5	152	140	124.5	104	77.5				
EV 1/25	1.5	2	20	174	164	151.5	134.5	112	83.5				
EV 1/27	1.5	2	20	187	176.5	162.5	144	120	88.5				
EV 1/30	1.5	2	20	206.5	194.5	179	158	131	96.5				
EV 1/32	2.2	3	20	224.5	213	197	175.5	147.5	110.5				
EV 1/34	2.2	3	20	238	225.5	208.5	185.5	155.5	116.5				
EV 1/37	2.2	3	20	258	244	225.5	200.5	167.5	125				
EV 3/2	0.37	0.5	20	15		15	14.5	13.5	12.5	11.5	10	8	6
EV 3/3	0.37	0.5	20	22.5		22	21	20	18.5	17	14.5	12	8.5
EV 3/4	0.37	0.5	20	30		28.5	27.5	26	24	21.5	18.5	15	10.5
EV 3/5	0.55	0.75	20	37.5		36	34.5	32.5	30	27	23.5	18.5	13
EV 3/6	0.55	0.75	20	44.5		42.5	40.5	38.5	35.5	32	27	21.5	15
EV 3/7	0.75	1	20	52.5		50.5	48.5	46	43	38.5	33	26.5	19
EV 3/8	0.75	1	20	59.5		57.5	55	52	48	43.5	37	29.5	21
EV 3/9	0.75	1	20	67		64	61.5	58	53.5	48	41	32.5	22.5
EV 3/10	1.1	1.5	20	75		72.5	70	66.5	61.5	55.5	48	38.5	27.5
EV 3/11	1.1	1.5	20	82.5		79.5	76.5	72.5	67	60.5	52	42	29.5
EV 3/12	1.1	1.5	20	89.5		86	83	78.5	72.5	65	56	45	31.5
EV 3/13	1.1	1.5	20	96.5		93	89	84.5	78	70	60	47.5	33.5
EV 3/14	1.5	2	20	105.5		102	98.5	93.5	86.5	78	67.5	54.5	39.5
EV 3/15	1.5	2	20	112.5		109	105	99.5	92.5	83	71.5	58	41.5
EV 3/16	1.5	2	20	120		115.5	111.5	105.5	98	88	76	61	43.5
EV 3/17	1.5	2	20	127		122.5	118	111.5	103.5	93	80	64	45.5
EV 3/18	2.2	3	20	136.5		132.5	128	121.5	113.5	102.5	89	72.5	53
EV 3/19	2.2	3	20	144		139.5	134.5	128	119	107.5	93.5	76	55.5
EV 3/21	2.2	3	20	158.5		153.5	148	140.5	130.5	118	102	83	60
EV 3/23	2.2	3	20	173		167.5	161.5	153	142	128	110.5	89.5	64.5
EV 3/25	2.2	3	20	187.5		181	174.5	165.5	153.5	138	119	96	68.5
EV 3/27	3	4	20	205.5		199.5	193	184	171.5	155	135	110.5	81
EV 3/29	3	4	20	220		213.5	206.5	196.5	183.5	166	144	117.5	86
EV 3/31	3	4	20	235		228	220.5	209.5	195	176.5	153	124.5	91
EV 3/33	3	4	20	249.5		242	234	222	206.5	187	162	131.5	95.5

EV 6-10

Pump model	RATED POWER		Q = DELIVERY															
			H1	1/min 0	42	50.0	58.3	67	75.0	83.3	90	100.0	116.7	133	150.0	166.7	183	233.3
	[kW]	[HP]	Bar	m ³ /h 0	2.5	3	3.5	4	4.5	5	5.4	6	7	8	9	10	11	14
			H = TOTAL HEAD - METERS COLUMN OF WATER [m]															
EV 6/2	0.37	0.5	20	15	14	13.5	13	12.5	12	11.5	11	10	8					
EV 6/3	0.37	0.5	20	22.5	20.5	19.5	19	18	17	16	15.5	14	11					
EV 6/4	0.55	0.75	20	29.5	27	26	25	24	22.5	21.5	20.5	18.5	14.5					
EV 6/5	0.75	1	20	37.5	34.5	33.5	32	30.5	29	27.5	26	24	19					
EV 6/6	0.75	1	20	44.5	41	39.5	37.5	36	34	32.5	30.5	28	22					
EV 6/7	1.1	1.5	20	52.5	49	47	45	43	41	39	37	34	27					
EV 6/8	1.1	1.5	20	59.5	55	53.5	51	48.5	46.5	44	42	38.5	30.5					
EV 6/9	1.1	1.5	20	67	61.5	59	56.5	54	51.5	48.5	46	42.5	33.5					
EV 6/10	1.5	2	20	75	70	67.5	65	62	59	56	53.5	49	39					
EV 6/11	1.5	2	20	82.5	76.5	73.5	71	67.5	64.5	61	58	53.5	42.5					
EV 6/12	1.5	2	20	89.5	83	80	76.5	73	69.5	65.5	62.5	57.5	45.5					
EV 6/13	1.5	2	20	97	89	86	82	78.5	74.5	70.5	67	61.5	48.5					
EV 6/14	2.2	3	20	105.5	99	95.5	92	88	83.5	79.5	76	70	56					
EV 6/15	2.2	3	20	113	105.5	102	98	93.5	89	84.5	80.5	74	59.5					
EV 6/16	2.2	3	20	120.5	112	108	104	99	94.5	89.5	85.5	78.5	62.5					
EV 6/17	2.2	3	20	127.5	118.5	114.5	109.5	105	99.5	94.5	90	83	66					
EV 6/18	2.2	3	20	135	125	120.5	115.5	110.5	105	99.5	94.5	87	69					
EV 6/19	2.2	3	20	142	131.5	126.5	121.5	115.5	110	104	99	91	72					
EV 6/20	3	4	20	152	142.5	138	133	127	121	115	110	101.5	82					
EV 6/21	3	4	20	159	149.5	144.5	139	133	127	120.5	115	106	85.5					
EV 6/23	3	4	20	174	163	157.5	151.5	144.5	138	131	125	115	92.5					
EV 6/25	3	4	20	189	175.5	170	164	157.5	150.5	142.5	135.5	123.5	98.5					
EV 6/28	4	5.5	20	214	200.5	194.5	188	181	173.5	164.5	156.5	143	115.5					
EV 6/30	4	5.5	20	229	214	207.5	200.5	193	184.5	175.5	167	152.5	122.5					
EV 6/33	4	5.5	20	251.5	234.5	227	219.5	211	201.5	191	182	166	133.5					
EV 6/36	5.5	7.5	20	275	257.5	249.5	241.5	232.5	222.5	211.5	201.5	184	148.5					
EV 10/2	0.75	1	20	20								18.5	17.5	17	16	15	13.5	9
EV 10/3	1.1	1.5	20	30								27.5	26.5	25.5	24	22.5	20.5	13.5
EV 10/4	1.5	2	20	40.5								37	35.5	34	32.5	30.5	28	18
EV 10/5	1.5	2	20	50.5								45.5	43.5	41.5	39.5	37	33.5	21.5
EV 10/6	2.2	3	20	61								56	54	51.5	49	46	42	27.5
EV 10/7	2.2	3	20	70.5								64.5	62	59.5	56	52.5	48	31
EV 10/8	3	4	20	81.5								75.5	73	70	66.5	62.5	57.5	38
EV 10/9	3	4	20	91.5								84.5	81.5	78	74	69.5	64	42
EV 10/10	4	5.5	20	102.5								96	93	89	84.5	79.5	73.5	49
EV 10/11	4	5.5	20	113								105	101.5	97.5	92.5	87	80.5	53.5
EV 10/12	4	5.5	20	123								114	110	105.5	100.5	94	87	57.5
EV 10/13	4	5.5	20	133								123	118.5	113.5	108	101	93.5	61.5
EV 10/15	5.5	7.5	20	153.5								142.5	138	132	125.5	118	109	72
EV 10/17	5.5	7.5	20	173.5								160.5	155	148.5	141	132.5	122	80.5
EV 10/19	7.5	10	20	195								182	176	169	160.5	151	139.5	93
EV 10/21	7.5	10	20	215.5								200	193.5	185.5	176.5	166	153	101.5
EV 10/23	7.5	10	20	235.5								218.5	211	202	192	180.5	166.5	110
EV 10/24	11	15	20	248								234	227	218	208	196	182	122.5

EV 15-20

Pump model	RATED POWER		Q = DELIVERY												
			H1	l/min 0	133	167	200	233	266	300	333	367	400	433.5	466.5
	[kW]	[HP]	Bar	m ³ /h 0	8	10	12	14	16	18	20	22	24	26	28
			H = TOTAL HEAD METERS COLUMN OF WATER [m]												
EV 15/1	1.1	1.5	20	14.5	13	12.5	12	11.5	10.5	9.5	8.5	7	5.5		
EV 15/2	2.2	3	20	29	26	25	24	23	21.5	19.5	17	14	11		
EV 15/3	3	4	20	43.5	39	38	36.5	34.5	32.5	29.5	26	21.5	17		
EV 15/4	4	5.5	20	58	52.5	51	49	46.5	44	40.5	35.5	29.5	23.5		
EV 15/5	4	5.5	20	72.5	65.5	63.5	60.5	57.5	54.5	49.5	43	36	28.5		
EV 15/6	5.5	7.5	20	87.5	79.5	77	74	71	67	61.5	54	46	36.5		
EV 15/7	5.5	7.5	20	102	92	89	86	82	77.5	70.5	62	52.5	41.5		
EV 15/8	7.5	10	20	117	106.5	103	99.5	95	90	82.5	72.5	62	49		
EV 15/9	7.5	10	20	131.5	119	115.5	111	106	100.5	92	81	69	54.5		
EV 15/10	11	15	20	147.5	134.5	131	126.5	121	115	106	94	80.5	65		
EV 15/11	11	15	20	162	148	143.5	139	133	126.5	116.5	103	88.5	71		
EV 15/12	11	15	20	176.5	161	156.5	151	144.5	137.5	126.5	112	96	77		
EV 15/13	11	15	20	191	174.5	169	163.5	156.5	148.5	136.5	120.5	103	82.5		
EV 15/14	11	15	20	205.5	187.5	182	175.5	168	159	146	129	110.5	88		
EV 15/15	15	20	20	221	201	195.5	188.5	180.5	171.5	157.5	139.5	119.5	95.5		
EV 15/16	15	20	20	235.5	214	208	200.5	192	182.5	167.5	148	126.5	101.5		
EV 15/17	15	20	20	249.5	227.5	220.5	213	203.5	193	177.5	156.5	134	107		
EV 20/1	1.1	1.5	20	15.5		13.5	13	13	12.5	12	11	10	8.5	7.5	6
EV 20/2	2.2	3	20	31		27.5	27	26	25	24	22.5	20.5	18	15	12
EV 20/3	3	4	20	46.5		41.5	40.5	39.5	38	36.5	34.5	31	27.5	23	18.5
EV 20/4	4	5.5	20	62.5		56	55	53.5	51.5	49.5	46.5	42.5	37	31.5	25.5
EV 20/5	5.5	7.5	20	78		70	68.5	66.5	64.5	62	58	53	47	40	32.5
EV 20/6	7.5	10	20	94.5		86.5	84.5	82.5	80	77.5	73.5	67.5	60	52	42.5
EV 20/7	7.5	10	20	110		100.5	98	95.5	93	90	85	77.5	69	59.5	48.5
EV 20/8	11	15	20	126.5		117	114	112	109	106	100.5	92.5	82.5	72	59.5
EV 20/9	11	15	20	142.5		131	128	125.5	122	118.5	112.5	103.5	92.5	80.5	66.5
EV 20/10	11	15	20	158		145.5	142	139	135	131.5	124.5	114	102	88.5	73
EV 20/11	15	20	20	174		160	156.5	153	149	144.5	137	126	113	98	81
EV 20/12	15	20	20	189.5		174.5	170.5	167	162	157.5	149	137	122.5	106.5	87.5
EV 20/13	15	20	20	205		188.5	184	180	175	170	161	147.5	132	114.5	94
EV 20/14	15	20	20	220.5		202.5	198	193.5	188	182.5	172.5	158	141	122	100.5
EV 20/15	18.5	25	20	237		217.5	212.5	208	202	196	185.5	170.5	152	132	108.5
EV 20/16	18.5	25	20	252.5		231.5	226	221	215	208.5	197	181	161.5	140	115
EV 20/17	18.5	25	20	268		245.5	240	234.5	227.5	221	209	191.5	171	148	121.5

EV 30-45

Pump model	RATED POWER		Q = DELIVERY									
			H1	l/min 0	417	500	583	667	750	900	1000	1083
	[kW]	[HP]	Bar	m ³ /h 0	25	30	35	40	45	54	60	65
	H = TOTAL HEAD METERS COLUMN OF WATER											
EV 30/1	2.2	3	20	24	19	17.5	16	13.5	11			
EV 30/2-2A	4	5.5	20	36	29.5	26.5	22.5	18	12.5			
EV 30/2-1A	4	5.5	20	42	34	31.5	27.5	23	18			
EV 30/2	5.5	7.5	20	48.5	39.5	36.5	33.5	29	23.5			
EV 30/3-2A	5.5	7.5	20	60	48	44	38	31.5	23.5			
EV 30/3-1A	7.5	10	20	66.5	54	50	45	38	30			
EV 30/3	7.5	10	20	73	59	55	50	43.5	35.5			
EV 30/4-2A	7.5	10	20	84.5	68	62	55	46	35			
EV 30/4-1A	11	15	20	91.5	75.5	70	63	54.5	43.5			
EV 30/4	11	15	20	98	80.5	75	69	60	49.5			
EV 30/5-2A	11	15	20	109.5	89.5	83	74	63	49.5			
EV 30/5-1A	11	15	10	115.5	94.5	88	79.5	68.5	55			
EV 30/5	15	20	11	122.5	100	93.5	85.5	75	61.5			
EV 30/6-2A	15	20	11	134	109.5	101.5	91	78	61.5			
EV 30/6-1A	15	20	12	140	114.5	106.5	96.5	83.5	67			
EV 30/6	15	20	13	146.5	119.5	111.5	102	89	73			
EV 30/7-2A	15	20	13	158	128.5	119	107	91.5	72.5			
EV 30/7-1A	15	20	14	164	133.5	124	112.5	97	78			
EV 30/7	18.5	25	15	171	139.5	130	119	103.5	85			
EV 30/8-2A	18.5	25	15	182.5	148.5	137.5	124	106	84.5			
EV 30/8-1A	18.5	25	15	188.5	153.5	142.5	129.5	111.5	90			
EV 30/8	18.5	25	15	194.5	158.5	147.5	134.5	117	95.5			
EV 30/9-2A	22	30	17	208.5	171	159	144	124.5	100.5			
EV 30/9-1A	22	30	17	214.5	176.5	164.5	150	130	106			
EV 30/9	22	30	20	221	181.5	169.5	155.5	136	112			
EV 30/10-2A	22	30	20	233	191	177.5	161	139	112			
EV 30/10-1A	22	30	20	239	196	182.5	166.5	144.5	117.5			
EV 30/10	30	40	20	246.5	203.5	190.5	175	153.5	126.5			
EV 30/11-2A	30	40	20	258	213	198.5	180.5	156.5	127			
EV 30/11-1A	30	40	20	264.5	218	204	186	162	133			
EV 30/11	30	40	20	271	223.5	209	192	168	138.5			
EV 30/12-2A	30	40	20	282.5	233	217	197.5	171	139			
EV 30/12-1A	30	40	20	289	238	222.5	203	177	145			
EV 30/12	30	40	20	295	243	227.5	208.5	182.5	150.5			
EV 30/13-2A	30	40	20	307	252.5	235.5	214	185.5	151			
EV 30/13-1A	30	40	20	313	258	240.5	220	191.5	156.5			
EV 30/13	30	40	20	319.5	263	246	225.5	197	162.5			
EV 45/1-1A	3	4	20	19			16.5	15.5	14.5	11.5	9.5	7.5
EV 45/1	4	5.5	20	24.5			21.5	21	19.5	17	15.5	13.5
EV 45/2-2A	5.5	7.5	20	38.5			33	31	28.5	23	18.5	14.5
EV 45/2	7.5	10	20	48.5			43	41.5	39	34	30.5	26.5
EV 45/3-2A	11	15	20	63			56	53.5	50	42	36	30
EV 45/3	11	15	20	73.5			65.5	63	60	52.5	47	41
EV 45/4-2A	15	20	8	87.5			77.5	74	69.5	59.5	51	43
EV 45/4	15	20	11	97.5			86.5	84	79.5	69.5	62	54.5
EV 45/5-2A	18.5	25	11	112			99	94.5	89	76.5	66	56
EV 45/5	18.5	25	14	122			108	104.5	99	86.5	77	67.5
EV 45/6-2A	22	30	14	137.5			122	117.5	110.5	95.5	83.5	72
EV 45/6	22	30	17	147.5			131.5	127	121	106	95	83.5
EV 45/7-2A	30	40	17	162.5			145	139.5	132	115	101	87.5
EV 45/7	30	40	20	172.5			154.5	149.5	142.5	125.5	112	99
EV 45/8-2A	30	40	20	187			167	160.5	152	132	116.5	101
EV 45/8	30	40	20	197			176.5	170.5	162.5	142.5	127.5	112.5
EV 45/9-2A	37	50	20	211.5			188.5	181.5	172	149.5	132	114.5
EV 45/9	37	50	20	221.5			198	191.5	182	160	143	126
EV 45/10-2A	37	50	20	235.5			210	202	191.5	166.5	147	127.5
EV 45/10	37	50	20	246			219	212	201.5	177	158	139
EV 45/11-2A	45	60	20	261			233	224.5	213	186	164.5	143.5
EV 45/11	45	60	20	271			242.5	234.5	223.5	196.5	175.5	155
EV 45/12-2A	45	60	20	285.5			254.5	245.5	232.5	203	179.5	156.5
EV 45/12	45	60	20	295.5			264	255.5	243	213.5	191	168.5
EV 45/13-2A	45	60	20	309.5			276	266	252.5	220.5	195	170

EV 65-95

Pump model	RATED POWER		Q = DELIVERY													
			H1	l/min 0	500	600	700	750	900	1000	1200	1300	1417	1600	1800	1967
	[kW]	[HP]	Bar	m ³ /h 0	30	36	42	45	54	60	72	78	85	96	108	118
			H = TOTAL HEAD - METERS COLUMN OF WATER													
EV 65/1-1A	4	5.5	20	19.5	19	18.5	18	17.5	16.5	15.5	12.5	11	9			
EV 65/1	5.5	7.5	20	28	25	24.5	24	23.5	22.5	22	20	18.5	16.5			
EV 65/2-2A	7.5	10	20	39	37.5	36.5	35.5	35	33	31	25	22	17.5			
EV 65/2-1A	11	15	20	48	44.5	43.5	42.5	42	40	38.5	34	31	26.5			
EV 65/2	11	15	20	56.5	51	49.5	48.5	48	46	45	41	38.5	34.5			
EV 65/3-2A	15	20	20	67.5	63.5	62	60.5	59.5	56.5	54	46.5	42	35.5			
EV 65/3-1A	15	20	20	76	69.5	68	66.5	65.5	62.5	60.5	53.5	49.5	43			
EV 65/3	18.5	25	20	84.5	76	74	72.5	71.5	69	67	61.5	57.5	51.5			
EV 65/4-2A	18.5	25	20	95.5	88.5	86	84	83	79	75.5	66	60.5	52			
EV 65/4-1A	22	30	20	105	96	93.5	91.5	90.5	87	84	75.5	70	62			
EV 65/4	22	30	20	113.5	102.5	100	97.5	96.5	92.5	90.5	83	78	70			
EV 65/5-2A	30	40	20	125	116	113	110.5	109	104.5	101	90	83	72.5			
EV 65/5-1A	30	40	20	133.5	122.5	119	116.5	115	110.5	107.5	97.5	90.5	80.5			
EV 65/5	30	40	20	142	129	125.5	122.5	121	116.5	114	105	98.5	88.5			
EV 65/6-2A	30	40	20	153	141.5	137.5	134.5	133	127.5	123	110	102	89.5			
EV 65/6-1A	37	50	20	162	148	144	141	139	133.5	129.5	117.5	109.5	97.5			
EV 65/6	37	50	20	170	154	150	147	145	139.5	136	125	117.5	105.5			
EV 65/7-2A	37	50	20	181.5	166.5	162.5	158.5	156.5	150	145	130.5	120.5	106.5			
EV 65/7-1A	37	50	20	189.5	173	168.5	164.5	162.5	156	151.5	138	128.5	114.5			
EV 65/7	45	60	20	199	180.5	175.5	172	169.5	163.5	159.5	147	138	124			
EV 65/8-2A	45	60	20	210	193	188	184	181.5	174	168.5	152	141.5	125			
EV 65/8-1A	45	60	20	218.5	199.5	194	190	187.5	180	175	159.5	149	133			
EV 65/8	45	60	20	227	206	200	196	193.5	186	181.5	167	157	141			
EV 95/1-1A	5.5	7.5	20	22				21	20.5	20	19	17.5	16.5	13.5	10	6.5
EV 95/1	7.5	10	20	30.5				27.5	26	25.5	24	23.5	22	20	17	13.5
EV 95/2-2A	11	15	20	44.5				43	42	41	38.5	36.5	34	28.5	21.5	15
EV 95/2	15	20	20	62				55.5	53	51.5	49	47.5	45	41	35	28.5
EV 95/3-2A	18.5	25	20	75.5				70.5	68	66.5	62.5	59.5	56	48.5	38.5	28.5
EV 95/3	22	30	20	93.5				84	80.5	78	74	72	69	62.5	53.5	44
EV 95/4-2A	30	40	20	108				100	97	94.5	89	85.5	81	71.5	59	46
EV 95/4	30	40	20	125.5				112.5	108	105	99.5	96.5	92.5	84	72	60
EV 95/5-2A	37	50	20	139				127.5	123.5	120	113.5	109	103.5	92	76	60
EV 95/5	37	50	20	156				140	134.5	130.5	123.5	120	114.5	104.5	89	74
EV 95/6-2A	45	60	20	170.5				156	150.5	146.5	138.5	134	127	113.5	94.5	75.5
EV 95/6	45	60	20	188				169	161.5	157	149	144.5	138.5	126	108	89.5

Spare parts and materials

EV 1/.../A - 3/.../A - 6/.../A - 10/.../A

CONFIGURATION FROM 5.5 KW WITH MOTOR ADAPTER

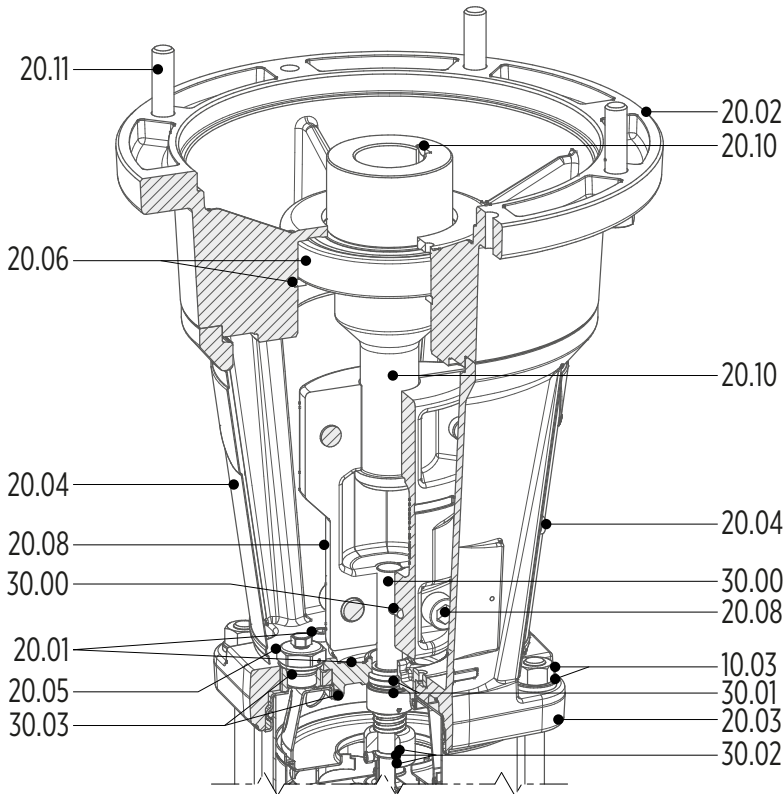

CONFIGURATION UP TO 4 KW

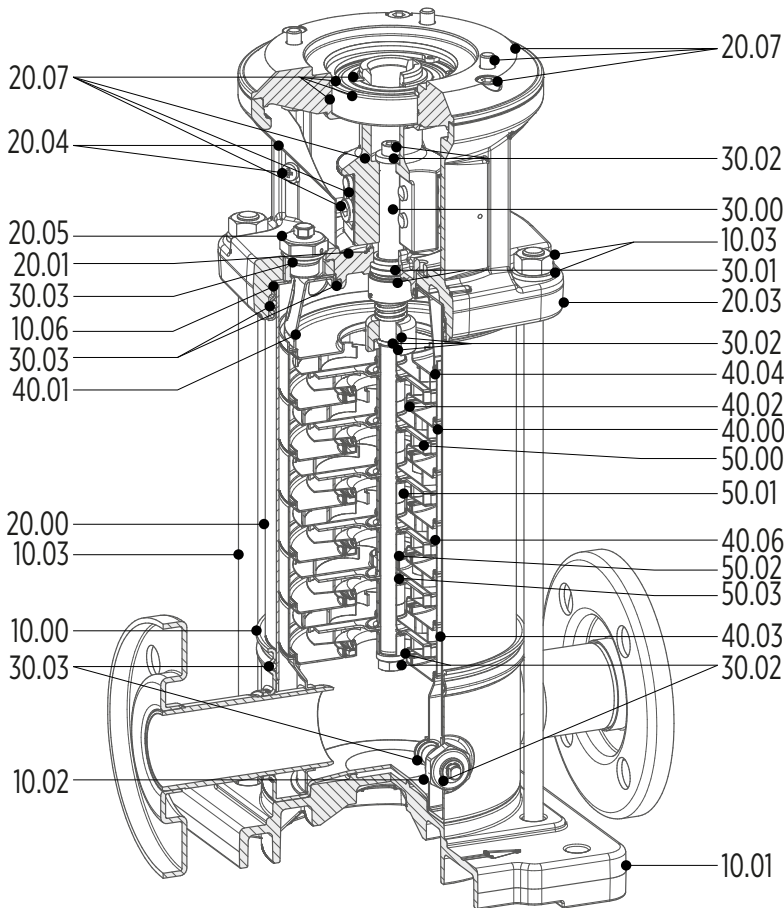

0003010 09/2019

PARTS IN CONTACT WITH LIQUID

Ref. No	Parts description	Material	Reference standard			
			I version		N version	
			ASTM	DIN/EN	ASTM	DIN/EN
10.00	Pump casing	Stainless Steel	AISI 304	1.4301	AISI 316L	1.4404
10.02	Draining plug	Stainless Steel	AISI 304	1.4301	AISI 316	1.4401
10.06	Upper flange	Stainless Steel	AISI 304	1.4301	AISI 316L	1.4404
20.00	Outer case	Stainless Steel	AISI 304	1.4301	AISI 316L	1.4404
20.01	Mechanical seal housing	Stainless Steel	CF 8 / AISI 304	1.4308	CF 8M / AISI 316	1.4408
20.05	Filling plug	Stainless Steel	AISI 304	1.4301	AISI 316	1.4401
30.00	Pump shaft	Stainless Steel	AISI 304	1.4301	AISI 316L	1.4404
30.01	Kit mechanical seal	Stainless steel, Carbon graphite, Silicon Carbide (SiC), EPDM	-	-	-	-
30.02	Mechanical seal fastening kit	Stainless Steel	AISI 304	1.4301	AISI 316	1.4401
30.03	Kit O-rings	EPDM	-	-	-	-
40.00	Stage housing and diffuser	Stainless Steel	AISI 304	1.4301	AISI 316L	1.4404
40.01	Stage Centering outlet	Stainless Steel	AISI 304	1.4301	AISI 316L	1.4404
40.02	Floating neck ring	Stainless steel, PPS	AISI 304	1.4301	AISI 316	1.4401
40.03	Initial stage housing	Stainless Steel	AISI 304	1.4301	AISI 316L	1.4404
40.04	Last Stage with diffuser	Stainless Steel	AISI 304	1.4301	AISI 316L	1.4404
40.06	Stage housing and diffuser with bearing	Stainless Steel, Tungsten carbide (WC)	AISI 304	1.4301	AISI 316	1.4401
50.00	Impeller	Stainless Steel	AISI 304	1.4301	AISI 316L	1.4404
50.01	Impeller spacer	Stainless Steel	AISI 304	1.4301	AISI 316L	1.4404
50.02	Intermediary sleeve	Tungsten Carbide (WC)	-	-	-	-
50.03	Intermediary sleeve spacer	Stainless Steel	AISI 304	1.4301	AISI 316L	1.4404

SPARE PARTS LIST

Ref. No	Parts description
10.00	Pump casing
10.01	Pump base
10.02	Draining plug
10.03	Tie bolts, washers and nuts
10.06	Upper flange
20.00	Outer case
20.01	Mechanical seal housing
20.02	Motor flange
20.03	Motor bracket
20.04	Coupling guard
20.05	Filling plug
20.06	Kit bearings
20.07	Motor flange, coupling and bearing kit
20.08	Coupling
20.10	Motor shaft adapter

Ref. No	Parts description
20.11	Lifting eyelets and bolts
30.00	Pump shaft
30.01	Kit mechanical seal
30.02	Mechanical seal fastening kit
30.03	Kit O-rings
40.00	Stage housing and diffuser
40.01	Stage Centering outlet
40.02	Floating neck ring
40.03	Initial stage housing
40.04	Last Stage with diffuser
40.06	Stage housing and diffuser with bearing
50.00	Impeller
50.01	Impeller spacer
50.02	Intermediate sleeve
50.03	Intermediate sleeve spacer

EV 15/.../A - 20/.../A

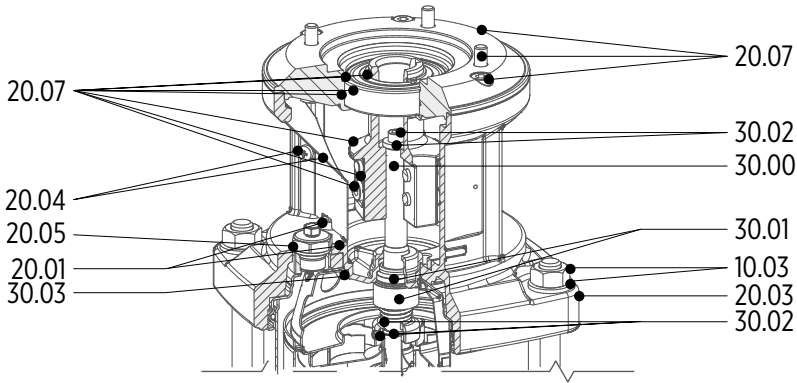

CONFIGURATION UP TO 4 KW

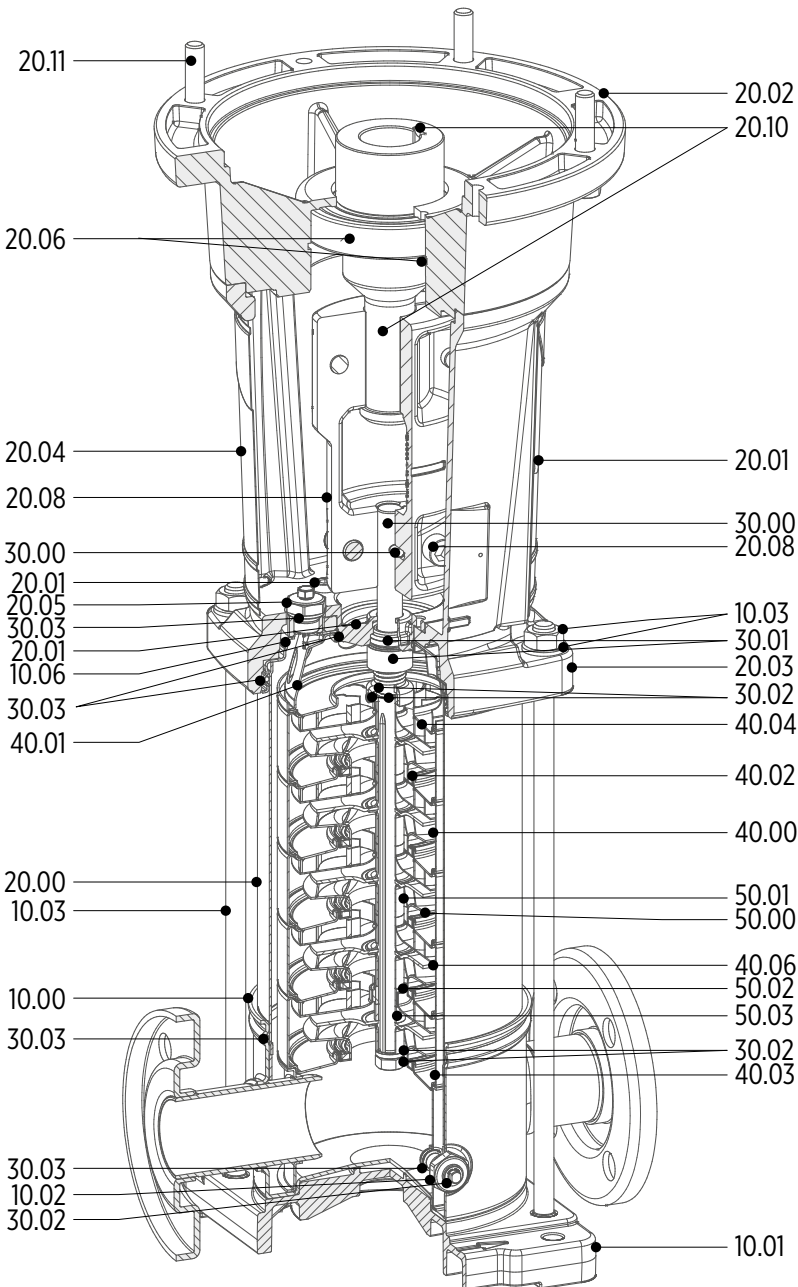

CONFIGURATION FROM 5.5 KW WITH MOTOR ADAPTER

6102/6111/030

PARTS IN CONTACT WITH LIQUID

Ref. No	Parts description	Material	Reference standard			
			I version		N version	
			ASTM	DIN/EN	ASTM	DIN/EN
10.00	Pump casing	Stainless Steel	AISI 304	1.4301	AISI 316L	1.4404
10.02	Draining plug	Stainless Steel	AISI 304	1.4301	AISI 316	1.4401
10.06	Upper flange	Stainless Steel	AISI 304	1.4301	AISI 316L	1.4404
20.00	Outer case	Stainless Steel	AISI 304	1.4301	AISI 316L	1.4404
20.01	Mechanical seal housing	Stainless Steel	CF 8 / AISI 304	1.4308	CF 8M / AISI 316	1.4408
20.05	Filling plug	Stainless Steel	AISI 304	1.4301	AISI 316	1.4401
30.00	Pump shaft	Stainless Steel	AISI 304	1.4301	AISI 316L	1.4404
30.01	Kit mechanical seal	Stainless steel, Carbon graphite, Silicon Carbide (SiC), EPDM	-	-	-	-
30.02	Mechanical seal fastening kit	Stainless Steel	AISI 304	1.4301	AISI 316	1.4401
30.03	Kit O-rings	EPDM	-	-	-	-
40.00	Stage housing and diffuser	Stainless Steel	AISI 304	1.4301	AISI 316L	1.4404
40.01	Stage Centering outlet	Stainless Steel	AISI 304	1.4301	AISI 316L	1.4404
40.02	Floating neck ring	Stainless steel, PPS	AISI 304	1.4301	AISI 316	1.4401
40.03	Initial stage housing	Stainless Steel	AISI 304	1.4301	AISI 316L	1.4404
40.04	Last Stage with diffuser	Stainless Steel	AISI 304	1.4301	AISI 316L	1.4404
40.06	Stage housing and diffuser with bearing	Stainless Steel, Tungsten carbide (WC)	AISI 304	1.4301	AISI 316	1.4401
50.00	Impeller	Stainless Steel	AISI 304	1.4301	AISI 316L	1.4404
50.01	Impeller spacer	Stainless Steel	AISI 304	1.4301	AISI 316L	1.4404
50.02	Intermediary sleeve	Tungsten Carbide (WC)	-	-	-	-
50.03	Intermediary sleeve spacer	Stainless Steel	AISI 304	1.4301	AISI 316	1.4401

SPARE PARTS LIST

Ref. No	Parts description
10.00	Pump casing
10.01	Pump base
10.02	Draining plug
10.03	Tie bolts, washers and nuts
10.06	Upper flange
20.00	Outer case
20.01	Mechanical seal housing
20.02	Motor flange
20.03	Motor bracket
20.04	Coupling guard
20.05	Filling plugs
20.06	Kit bearings
20.07	Motor flange, coupling and bearing kit
20.08	Coupling
20.10	Motor shaft adapter

Ref. No	Parts description
20.11	Lifting eyelets and bolts
30.00	Pump shaft
30.01	Kit mechanical seal
30.02	Mechanical seal fastening kit
30.03	Kit O-rings
40.00	Stage housing and diffuser
40.01	Stage Centering outlet
40.02	Floating neck ring
40.03	Initial stage housing
40.04	Last Stage with diffuser
40.06	Stage housing and diffuser with bearing
50.00	Impeller
50.01	Impeller spacer
50.02	Intermediate sleeve
50.03	Intermediate sleeve spacer

EV 30-45-65-95

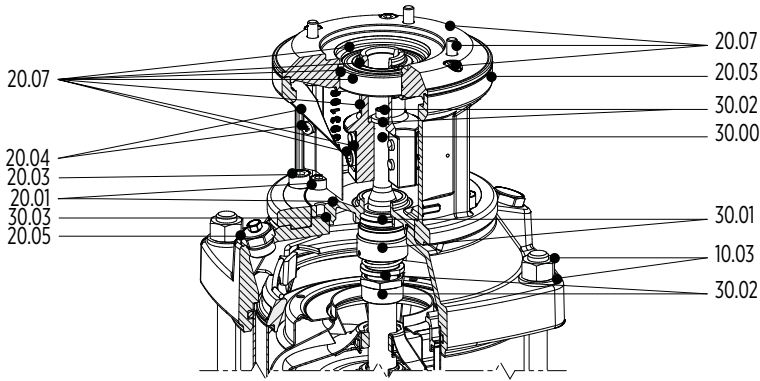

CONFIGURATION UP TO 4 KW

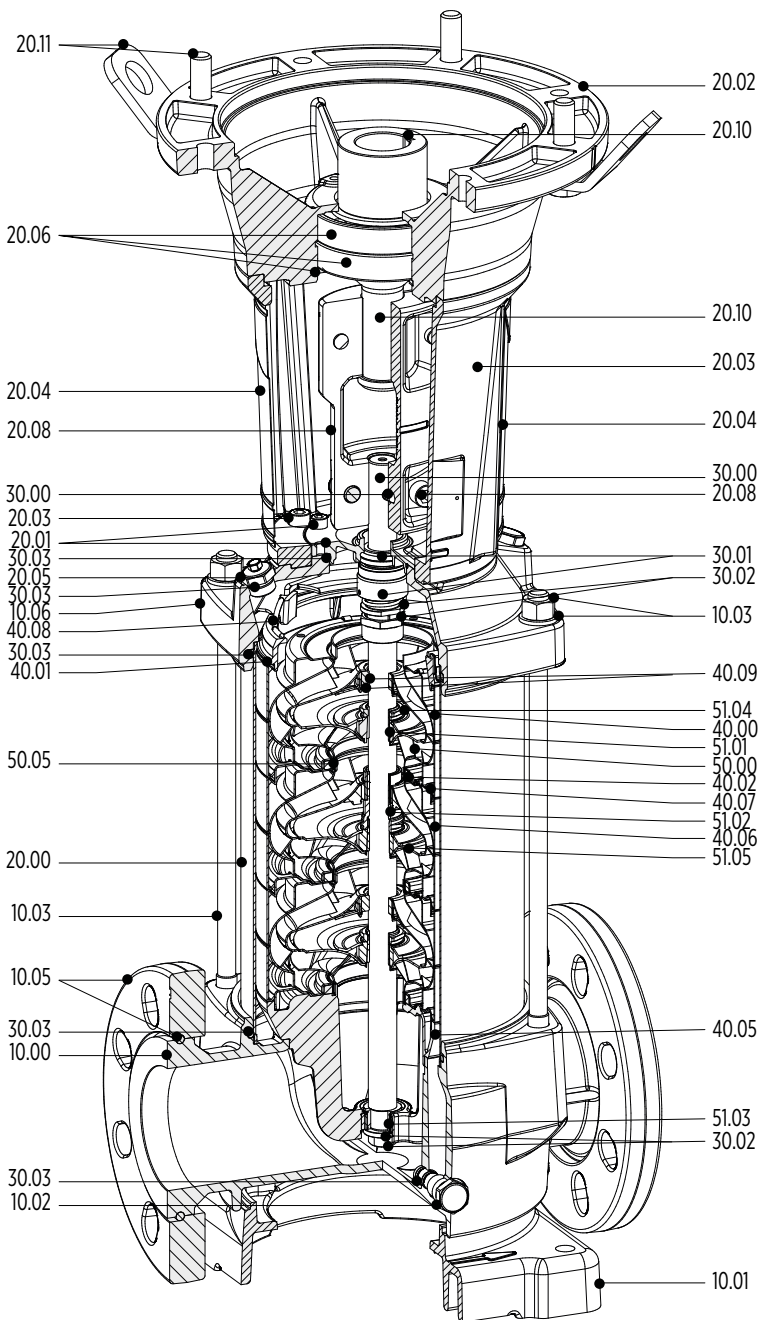

CONFIGURATION FROM 5.5 KW WITH MOTOR ADAPTER

00153012 09/2019

PARTS IN CONTACT WITH LIQUID

Ref. No	Parts description	Material	Reference standard			
			G version		N version	
			ASTM	DIN/EN	ASTM	DIN/EN
10.00	Pump casing	Cast Iron / Stainless Steel	A48 Class 35	GJL-250	CF 8M / AISI 316	1.4408
10.02	Draining plug	Stainless Steel	AISI 304	1.4301	AISI 316	1.4401
10.06	Upper flange	Cast Iron / Stainless Steel	A48 Class 35	GJL-250	CF 8M / AISI 316	1.4408
20.00	Outer case	Stainless Steel	AISI 304	1.4301	AISI 316L	1.4404
20.01	Mechanical seal housing	Stainless Steel	CF 8 / AISI 304	1.4308	CF 8M / AISI 316	1.4408
20.05	Filling plugs	Stainless Steel	AISI 304	1.4301	AISI 316	1.4401
30.00	Pump shaft	Stainless Steel	AISI 431	1.4057	AISI 329	1.4460
30.01	Kit mechanical seal	Stainless steel, Carbon graphite, Silicon Carbide (SiC), EPDM	-	-	-	-
30.02	Mechanical seal fastening kit	Stainless Steel	AISI 316	1.4401	AISI 316	1.4401
30.03	Kit O-rings	EPDM	-	-	-	-
40.00	Stage housing and diffuser	Stainless Steel	AISI 304	1.4301	AISI 316L	1.4404
40.01	Stage Centering outlet (only for EV 65 and 95)	Stainless Steel	CF 8 / AISI 304	1.4308	CF 8M / AISI 316	1.4408
40.02	Floating neck ring	PTFE	-	-	-	-
40.05	Stage Centering inlet	Stainless Steel, Tungsten Carbide (WC)	AISI 316	1.4401	AISI 316	1.4401
40.06	Stage housing and diffuser with bearing	Stainless Steel, Tungsten Carbide (WC)	AISI 304	1.4301	AISI 316	1.4401
40.07	Flange clamping neck ring	Stainless Steel	AISI 304	1.4301	AISI 316L	1.4404
40.08	Spring ring	Stainless Steel	AISI 316	1.4401	AISI 316	1.4401
40.09	Secondary sleeve with ring	Stainless Steel, Carbon graphite	AISI 316	1.4401	AISI 316	1.4401
50.00	Impeller	Stainless Steel	AISI 304	1.4301	AISI 316L	1.4404
50.05	Wear ring	Stainless Steel	AISI 304	1.4301	AISI 316L	1.4404
51.01	Split cone	Stainless Steel	AISI 304	1.4301	AISI 316	1.4401
51.02	Intermediary sleeve nut	Stainless Steel, Tungsten Carbide (WC)	AISI 316	1.4401	AISI 316	1.4401
51.03	Journal sleeve	Stainless Steel, Tungsten Carbide (WC)	AISI 316	1.4401	AISI 316	1.4401
51.04	Split cone nut	Stainless Steel	AISI 304	1.4301	AISI 316L	1.4404
51.05	Intermediate impeller with screw	Stainless Steel	AISI 304	1.4301	AISI 316L	1.4404

SPARE PARTS LIST

Ref. No	Parts description
10.00	Pump casing
10.01	Pump base
10.02	Draining plug
10.03	Tie bolts, washers and nuts
10.05	Kit flanges ring
10.06	Upper flange
20.00	Outer case
20.01	Mechanical seal housing
20.02	Motor flange
20.03	Motor bracket
20.04	Coupling guard
20.05	Filling plugs
20.06	Kit bearings
20.07	Motor flange, coupling and bearing kit
20.08	Coupling
20.10	Motor shaft adapter
20.11	Lifting eyelets and bolts
30.00	Pump shaft

Ref. No	Parts description
30.01	Kit mechanical seal
30.02	Mechanical seal fastening kit
30.03	Kit O-rings
40.00	Stage housing and diffuser
40.01	Stage Centering outlet (ONLY 65/95 vers.)
40.02	Floating neck ring
40.05	Stage Centering inlet
40.06	Stage housing and diffuser with bearing
40.07	Flange clamping neck ring
40.08	Spring ring
40.09	Secondary sleeve with ring
50.00	Impeller
50.05	Wear ring
51.01	Split cone
51.02	Intermediate sleeve nut
51.03	Journal sleeve
51.04	Split cone nut
51.05	Intermediate impeller with screw

MOTORS AEG

FEATURES

- Protection degree: IP55
- Max ambient temperature: 40 °C
- Insulation class: F
- Size B14 up to 4 kW, size B5 from 5.5 kW and above
- **The pumps are according to EU regulation No 640/2009**
For more information please consult the documents "Energy efficiency_EV" in our website franklinwater.eu available in "download" section of product page.



SINGLE-PHASE MOTORS

- Standard Voltage: 230 V
- Capacitor inside terminal box

SINGLE-PHASE MOTORS DESIGNED FOR RANGE OF RATED VOLTAGE 230 V 50 Hz											
POWER		IEC Size	Constr.design	I _N [A] 230 V	min ⁻¹	M _N [Nm]	η %	cos φ	I _A /I _N	M _A /M _N	Weight [Kg]
[kW]	[HP]										
0.37	0.5	71	B14	3.1	2780	1.3	57.6	0.89	3.1	0.8	7.1
0.55	0.75	71	B14	3.9	2740	1.9	69.0	0.89	3.5	0.7	8.5
0.75	1	80	B14	5.3	2800	2.6	65.0	0.95	4.1	0.6	11.4
1.1	1.5	80	B14	6.5	2730	3.8	74.0	0.97	3.6	0.5	11.8
1.5	2	90	B14	9.3	2835	5.1	73.0	0.90	3.9	0.5	17.3
2.2	3	90	B14	14.6	2770	7.6	73.0	0.90	4.3	0.2	19.3

THREE-PHASE MOTORS – ENERGY EFFICIENT

- High Efficiency three-phase motors from 0.75 kW in compliance with high efficiency IE3
- The standard design includes the following basic features to give a high level of flexibility:
 - Multi Mount Construction for an easy change of terminal box position
 - Terminal box rotates by 90° to allow cable entry from any direction
 - Easy-to-change flanges with over-sized and smaller-sized dimensions
 - Possibility to apply oil seal at drive end
 - Standard Voltage up to 3 kW 230/400 V, 400/690 V from 4 kW and above

THREE-PHASE MOTORS DESIGNED FOR RANGE OF RATED VOLTAGE 400 V 50 Hz															
Efficiency class	POWER		IEC Size	Constr. Design	I _N [A] Δ 230 V	I _N [A] Y 400 V	I _N [A] Δ 400V	I _N [A] Y 690V	min ⁻¹	M _N [Nm]	η %	cos φ	I _s /I _N	M _s /M _N	Weight [Kg]
	[kW]	[HP]													
IE2	0.37	0.5	71	B14	1.7	1.0	-	-	2820	1.3	70.0	0.78	4.7	3.6	5.8
	0.55	0.75	71	B14	2.6	1.5	-	-	2830	1.9	71.0	0.77	4.8	3.2	6.2
IE3	0.75	1	80	B14	2.9	1.7	-	-	2910	2.5	82.0	0.78	8.9	4.7	9.5
	1.1	1.5	80	B14	4.2	2.4	-	-	2870	3.7	82.7	0.76	9.3	5	11.1
	1.5	2	90	B14	5.2	3.0	-	-	2875	5.0	84.2	0.85	8.4	3.6	14.0
	2.2	3	90	B14	8.0	4.6	-	-	2880	7.3	86.5	0.82	9.2	4	16.0
	3	4	100	B14	9.7	5.6	-	-	2900	9.9	87.1	0.89	8.8	5.5	22.8
	4	5.5	112	B14	-	-	8	4.6	2900	13	88.1	0.83	10.7	5.1	26.5
	5.5	7.5	132	B5	-	-	10.2	5.9	2935	17.9	89.2	0.87	11.2	4.2	33.6
	7.5	10	132	B5	-	-	14.4	8.3	2930	24.5	90.1	0.84	10.4	4.5	36.0
	11	15	160	B5	-	-	19.9	11.5	2935	35.8	91.2	0.89	9.7	4.4	62.0
	15	20	160	B5	-	-	26.8	15.5	2915	49.2	91.9	0.88	9.6	3.7	68.0
	18.5	25	160	B5	-	-	33.0	19.1	2950	59.9	92.4	0.88	10.7	4.6	104.0
	22	30	180	B5	-	-	39.4	22.8	2950	71.3	92.7	0.87	10.4	4.5	106.0
	30	40	200	B5	-	-	52.7	30.5	2925	97.9	93.3	0.88	6.7	2.4	276.0
	37	50	200	B5	-	-	63.3	36.6	2930	120.6	93.7	0.90	6.3	2.3	283.0
45	60	225	B5	-	-	78.5	45.4	2930	146.7	94.0	0.88	6.9	2.3	370.0	

NEW INTERNATIONAL EFFICIENCY CLASSES OF MOTORS – IE CODE

The new IEC 60034-30:2008 defines the efficiency classes of motors worldwide.

IE1 = Standard Efficiency (comparable to EFF2)

IE2 = High Efficiency (comparable to EFF1)

IE3 = Premium Efficiency

The efficiency levels according to IEC 60034-30 are measured based on the test methods defined in IEC 60034-2-1:2007.

The IEC 60034-30 only defines requirements of efficiency classes and aims to create provisions for international consistency.

It does not define which motors must be supplied with which efficiency level. This is subject to respective regional legislation.

OUTPUT [Kw]	IE1 code Standard Efficiency			IE2 code Standard Efficiency			IE3 code Standard Efficiency		
	2 poles	4 poles	6 poles	2 poles	4 poles	6 poles	2 poles	4 poles	6 poles
0.75	72.1	72.1	70.0	77.4	79.6	75.9	80.7	82.5	78.9
1.1	75.0	75.0	72.9	79.6	81.4	78.1	82.7	84.1	81.0
1.5	77.2	77.2	75.2	81.3	82.8	79.8	84.2	85.3	82.5
2.2	79.7	79.7	77.7	83.2	84.3	81.8	85.9	86.7	84.3
3	81.5	81.5	79.7	84.6	85.5	83.3	87.1	87.7	85.6
4	83.1	83.1	81.4	85.8	86.6	84.6	88.1	88.6	86.8
5.5	84.7	84.7	83.1	87.0	87.7	86.0	89.2	89.6	88.0
7.5	86.0	86.0	84.7	88.1	88.7	87.2	90.1	90.4	89.1
11	87.6	87.6	86.4	89.4	89.8	88.7	91.2	91.4	90.3
15	88.7	88.7	87.7	90.3	90.6	89.7	91.9	92.1	91.2
18.5	89.3	89.3	88.6	90.9	91.2	90.4	92.4	92.6	91.7
22	89.9	89.9	89.2	91.3	91.6	90.9	92.7	93.0	92.2
30	90.7	90.7	90.2	92.0	92.3	91.7	93.3	93.6	92.9
37	91.2	91.2	90.8	92.5	92.7	92.2	93.7	93.9	93.3
45	91.7	91.7	91.4	92.9	93.1	92.7	94.0	94.2	93.7

Efficiency values according to IEC 60034-30:2008.

Efficiency standard calculation: IEC 60034-2-1:2007

NOISE

The noise level of an electrical machine is determined by measuring the sound pressure level in accordance with curve A of the sound level meter to EN 60651 and is indicated in dB (A). The permitted noise levels of electrical machines are fixed in EN 60034 - 9 (IEC 34-9). The noise level of the motors is below these limit values. Structure-borne sound measurements are carried out in an anechoic testing chamber to EN 21680-ISO 1680. The speed is corresponding to a main frequency of 50 Hz and the number of poles.

Noise levels

The noise values listed below refer to 50 Hz at rated voltage with a tolerance of up to +3 dB (A). Values for pole-changing motors are available on request. For 60 Hz supply, the values are 3-5 dB (A) higher. Sound pressure level (L_{pA}) and sound power level (L_{WA}) refers to three-phase motors with single-speed, dimensions and output ratings as per IEC 60072.

Frame size	2 pole		4 pole	
	L _{WA}	L _{pA}	L _{WA}	L _{pA}
56	57	48	47	38
63	58	49	47	38
71	61	52	51	42
80	72	60	60	48
90	74	62	61	49
100	78	66	62	50
112	80	68	65	53
132	81	72	71	59
160	87	74	75	62
180	90	77	78	66
200	91	78	80	68
225	92	80	88	76

MOTORS SPARE PARTS

UP TO 4 KW

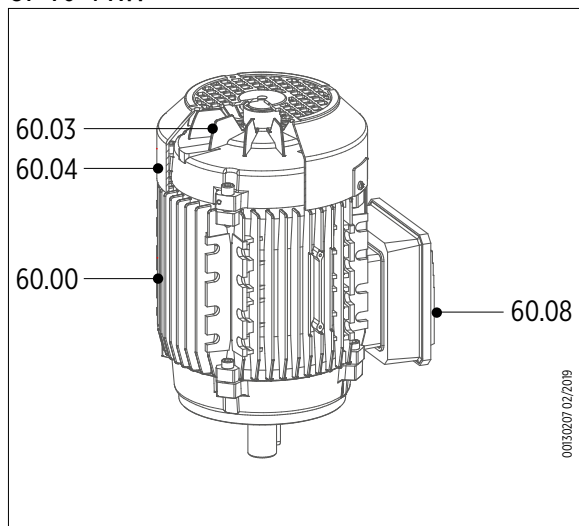

FROM 5.5 KW

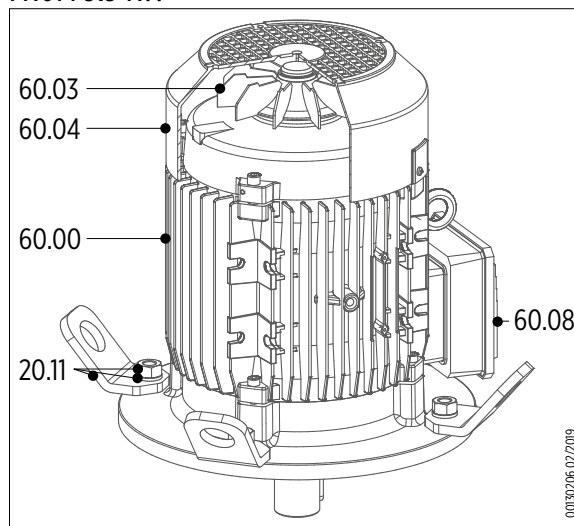

Ref. N.	Parts description
20.11	Lifting eyelets and bolts
60.00	Motor assembly
60.03	Fan
60.04	Fan cover and screws
60.08	Terminal box cover and base

MECHANICAL SEAL SPECIFICATIONS

(in accordance with EN 12756)

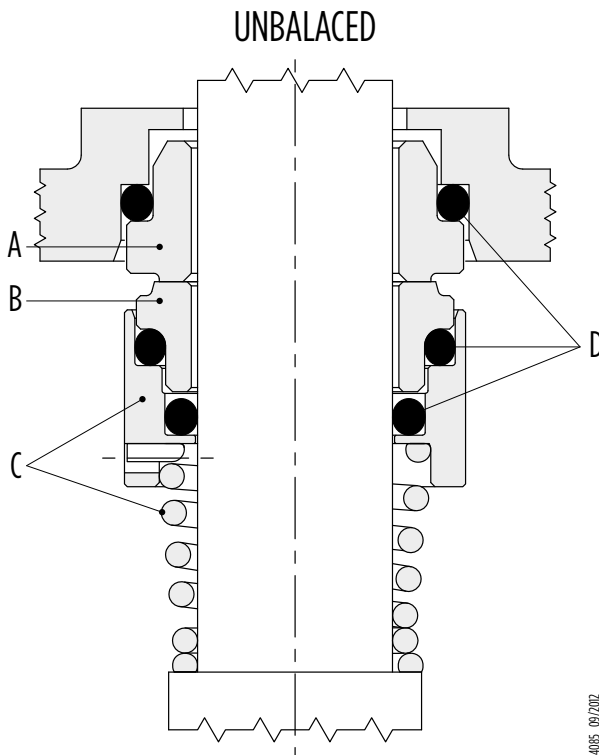

0014085 09/2012

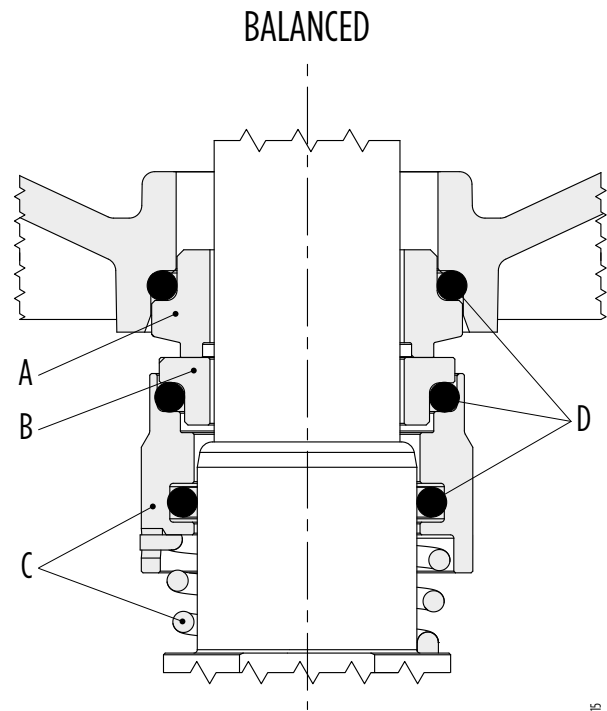

0014115 02/2015

STANDARD VERSION -UNBALANCED

Model	Type				Position				Temperature [°C]
					A Stationary part	B Rotating part	C Other components	D Elastomers	
E1*	B	Q	G	E	Graphite	Silicon carbide	AISI 316	EPDM	-15 /+120

AVAILABLE ON REQUEST

Model	Type				Position				Temperature [°C]
					A Stationary part	B Rotating part	C Other components	D Elastomers	
E2*	Q	Q	G	E	Silicon carbide	Silicon carbide	AISI 316	EPDM	-10 /+120
V3*	Q	Q	G	V	Silicon carbide	Silicon carbide	AISI 316	FKM	-10 /+120
V4*	B	Q	G	V	Graphite	Silicon carbide	AISI 316	FKM	-10 /+120
E5*	U	U	G	E	Tungsten carbide	Tungsten carbide	AISI 316	EPDM	-10 /+120
V6*	U	U	G	V	Tungsten carbide	Tungsten carbide	AISI 316	FKM	-10 /+120

* All models are available in balanced version "B..." (ex. E1 - standard version --> BE1 - balanced version)

Type	Material
B	Graphite
E	EPDM
G	AISI 316
Q	Silicon carbide
V	FKM
U	Tungsten carbide

COMPATIBILITY OF FLUIDS AND MATERIALS

Liquids (aqueous solutions)	Concentration [%]	Temperature Min/Max [°C]	EV models		
			G	I	N
Acetic acid	80	-10 ÷ +70			E1
Aluminium sulfate	30	-5 ÷ +50			E2
Ammonia in water	25	-20 ÷ +50		E1	E1
Ammonium sulfate	10	-10 ÷ +60			E2
Benzoic acid	70	0 ÷ +70			V4
Caustic soda	25	0 ÷ +70	E2	E2	E2
Chloroform	100	-10 ÷ +30	V4	V4	V4
Citric acid	5	-10 ÷ +70		E1	E1
Copper sulfate	20	+0 ÷ +30			V3
Deionised, demineralised water	100	-25 ÷ +110	E2	E2	E2
Diathermic oil	100	-5 ÷ +110	V4	V4	V4
Emulsion oil and water	-	-5 ÷ +90	V4	V4	V4
Ethylene glycol	30	-30 ÷ +120		E1	E1
Ferrous sulfate and ferric sulfate	10	+5 ÷ +30			E1
Formic acid	5	-15 ÷ +25		E1	E1
Glycerine	100	+20 ÷ +90	V4	V4	V4
Hydrochloric acid	2	-5 ÷ +25			V3
Mineral oil	100	-5 ÷ +110	V4	V4	V4
Nitric acid	50	-5 ÷ +30		V3	V3
Perchloroethylene	100	-10 ÷ +30	V4	V4	V4
Phosphates-polyphosphates	10	-5 ÷ +90		V3	V3
Phosphoric acid	10	-5 ÷ +30			E1
Propylene glycol	30	-30 ÷ +120	V3	V3	V3
Sea water *	-	-	-	-	-
Sodium bicarbonate (Baking soda)	6	+5 ÷ +60			E1
Sodium hypochlorite	1	-10 ÷ +25			V3
Sodium nitrate	10	+5 ÷ +60		V3	V3
Sodium sulfate	15	-10 ÷ +40	E2	E2	E2
Sulphuric acid	2	-10 ÷ +25	E2	E2	E2
Tannic acid	20	0 ÷ +50			E1
Tartaric acid	50	-10 ÷ +25		V3	V3
Trichloroethylene	100	-10 ÷ +40	V4	V4	V4
Vegetable oil	100	-5 ÷ +110	E1	E1	E1
Water	100	-5 ÷ +120	E1	E1	E1

* For sea water application, please contact the Technical Department.

The table is to be considered as a general guide. It is important to consider the specific working conditions, in particular the concentration of the pumped liquid, the specific weight of the liquid and/or viscosity, the liquid temperature and pressure. All these conditions are relevant for the motor and pump performance. When pumping dangerous liquids, it is recommended to take safety precautions. For further details, please contact Franklin Electric.

Performance Curves and Technical Data

EV 1 - 3 - 6 - 10 - 15 - 20 - 30 - 45 - 65 - 95
50 HZ

The pumps are according to EU regulation No 547/2012

For more information please consult the documents "Energy efficiency_EV" in our website franklinwater.eu available in "download" section of product page.



EV 1 - 50 Hz

TECHNICAL DATA

Pump Model	MOTOR		Dimensions [mm]											Weight [kg]			
			L1		L2		L3	L4	L5	M		D1		D2	L1+L2	Pump	Motor
	[kW]	Dim	F	1-PHASE	3-PHASE	T	V	C	1-PHASE	3-PHASE	1-PHASE	3-PHASE					
EV 1/2	0.37	71	313	216	216	288	288	288	134	110	139	139	170	529	11.5	5.8	17.3
EV 1/3	0.37	71	336	216	216	311	311	311	134	110	139	139	170	552	12	5.8	17.8
EV 1/4	0.37	71	358	216	216	333	333	333	134	110	139	139	170	574	12.5	5.8	18.3
EV 1/5	0.37	71	381	216	216	356	356	356	134	110	139	139	170	597	13	5.8	18.8
EV 1/6	0.37	71	403	216	216	378	378	378	134	110	139	139	170	619	13.5	5.8	19.3
EV 1/7	0.37	71	426	216	216	401	401	401	134	110	139	139	170	642	14	5.8	19.8
EV 1/8	0.55	71	448	216	216	423	423	423	134	110	139	139	170	664	14.5	6.2	20.7
EV 1/9	0.55	71	471	216	216	446	446	446	134	110	139	139	170	687	15	6.2	21.2
EV 1/10	0.55	71	493	216	216	468	468	468	134	110	139	139	170	709	15.5	6.2	21.7
EV 1/11	0.55	71	516	216	216	491	491	491	134	110	139	139	170	732	16	6.2	22.2
EV 1/12	0.75	80	538	232	232	513	513	513	150	129	160	160	170	770	16.5	9.5	26
EV 1/13	0.75	80	561	232	232	536	536	536	150	129	160	160	170	793	17	9.5	26.5
EV 1/14	0.75	80	583	232	232	558	558	558	150	129	160	160	170	815	17	9.5	26.5
EV 1/15	0.75	80	606	232	232	581	581	581	150	129	160	160	170	838	17.5	9.5	27
EV 1/17	1.1	80	651	232	232	626	626	626	150	129	160	160	170	883	18.5	11.1	29.6
EV 1/19	1.1	80	696	232	232	671	671	671	150	129	160	160	170	928	19.5	11.1	30.6
EV 1/22	1.1	80	763	232	232	738	738	738	150	129	160	160	170	995	21	11.1	32.1
EV 1/23	1.5	90	796	267	267	771	771	771	160	138	180	180	170	1063	22	14	36
EV 1/25	1.5	90	841	267	267	-	816	816	160	138	180	180	170	1108	23	14	37
EV 1/27	1.5	90	886	267	267	-	861	861	160	138	180	180	170	1153	24	14	38
EV 1/30	1.5	90	953	267	267	-	928	928	160	138	180	180	170	1220	25	14	39
EV 1/32	2.2	90	998	267	267	-	973	973	160	138	180	180	170	1265	26	16	42
EV 1/34	2.2	90	1043	267	267	-	1018	1018	160	138	180	180	170	1310	27	16	43
EV 1/37	2.2	90	1111	267	267	-	1086	1086	160	138	180	180	170	1378	28.5	16	44.5

DIMENSIONAL DRAWINGS

F Version

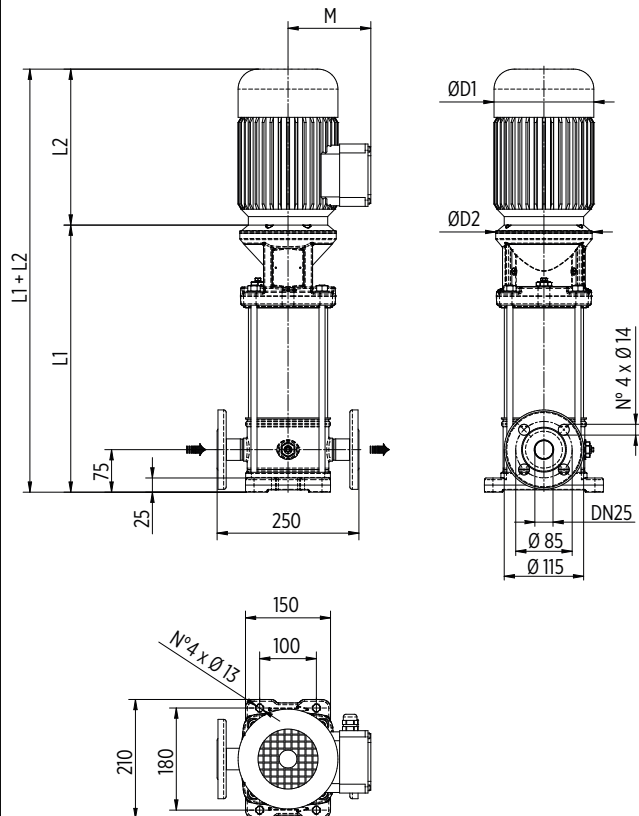

Round flanges on body type PN25: the pump is supplied without counterflanges (Optional accessories, including bolts and joints)

T Version

available from EV1/2 to EV1/23

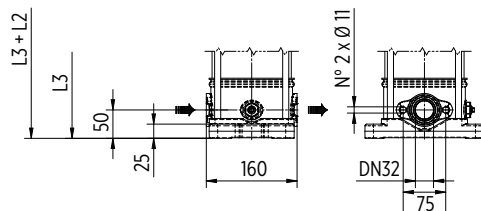

Oval flanges on body type PN16: the pump is supplied without threaded oval counter flanges (Optional accessories, including bolts and joints)

V Version

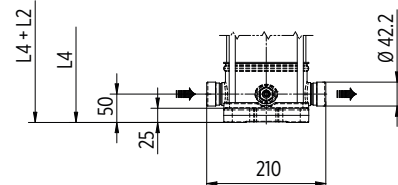

Connections with rapid fittings type "Victaulic": the pump is supplied without the collars (Optional accessories)

C Version

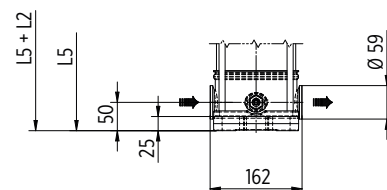

Connections with round fittings type Clamp-FlexiClamp: the pump is supplied without collars (Optional accessories)

0015009BEN 02/2018

EV 1 - PERFORMANCE CURVES AT 50 Hz

MEI ≥ 0,70

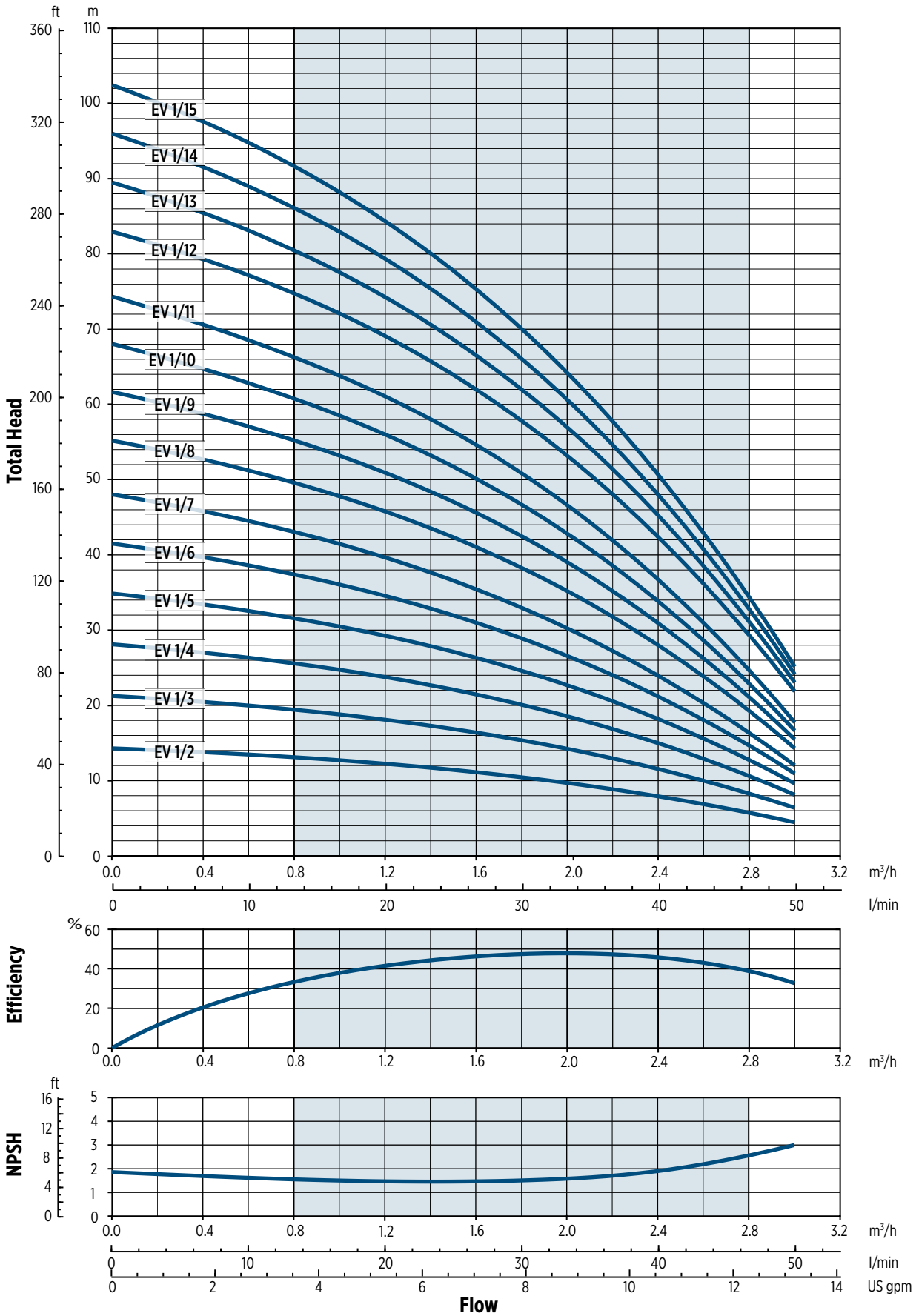

002014AEN 02/2018

The hydraulic characteristics are guaranteed, according to ISO Standard 9906:2012, grade 3B

EV 1 - PERFORMANCE CURVES AT 50 Hz

MEI ≥ 0,70

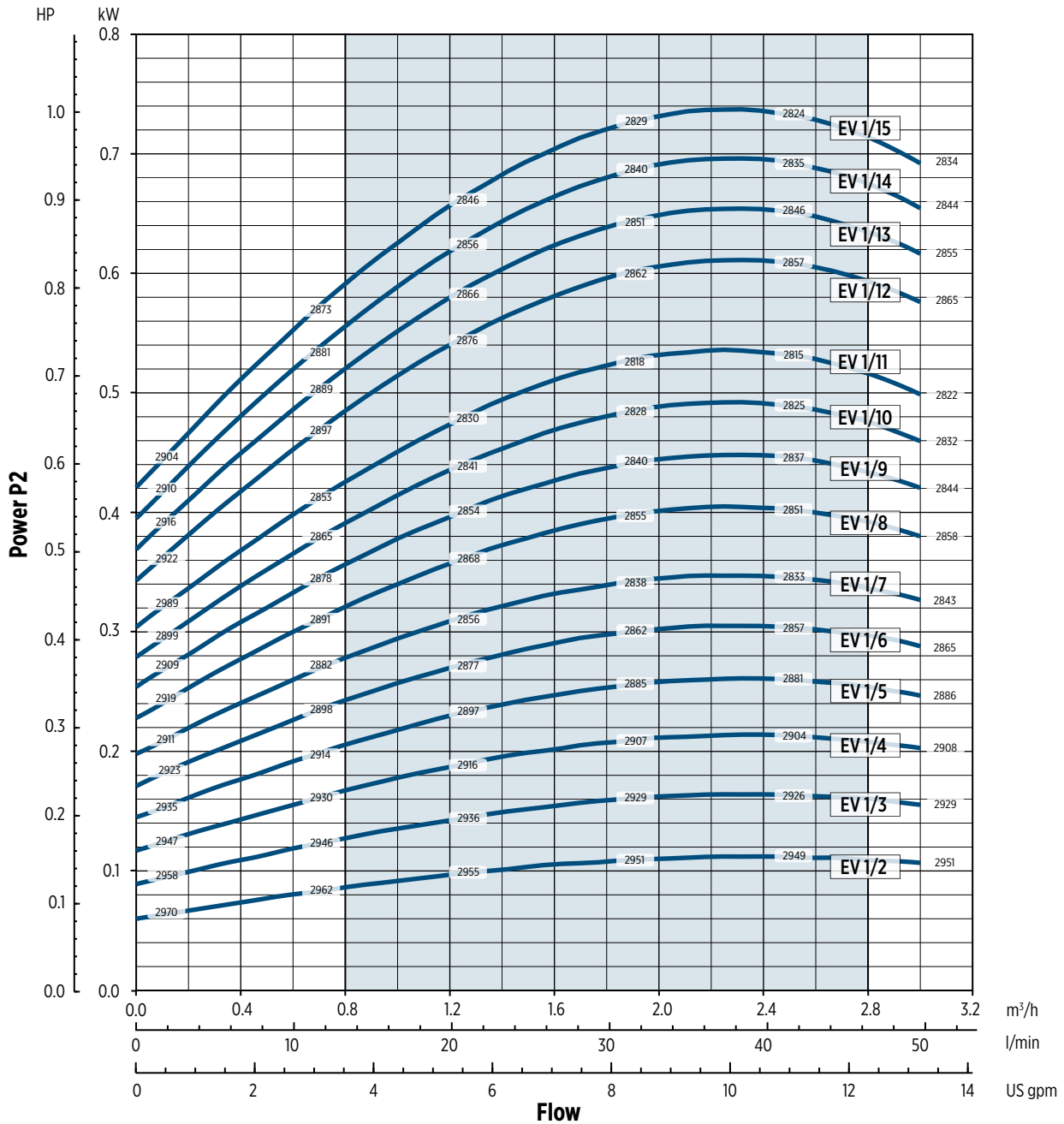

002014AEN 02/2018

Performance curves of Q, H and P depend on the rpm number according to the following formula:

$$Q_2 = Q_1 \cdot \left(\frac{n_2}{n_1}\right), \quad H_2 = H_1 \cdot \left(\frac{n_2}{n_1}\right)^2, \quad P_2 = P_1 \cdot \left(\frac{n_2}{n_1}\right)^3, \quad \eta \text{ remains approximately the same.}$$

The rpm number related to the performance curves (Q-H-P) is indicated in the power chart.

Performance curves (Q-H-P) will change according to the formulas above.

Q=Capacity, H=Head, P=Power, h=Efficiency

EV 1 - PERFORMANCE CURVES AT 50 Hz

MEI ≥ 0,70

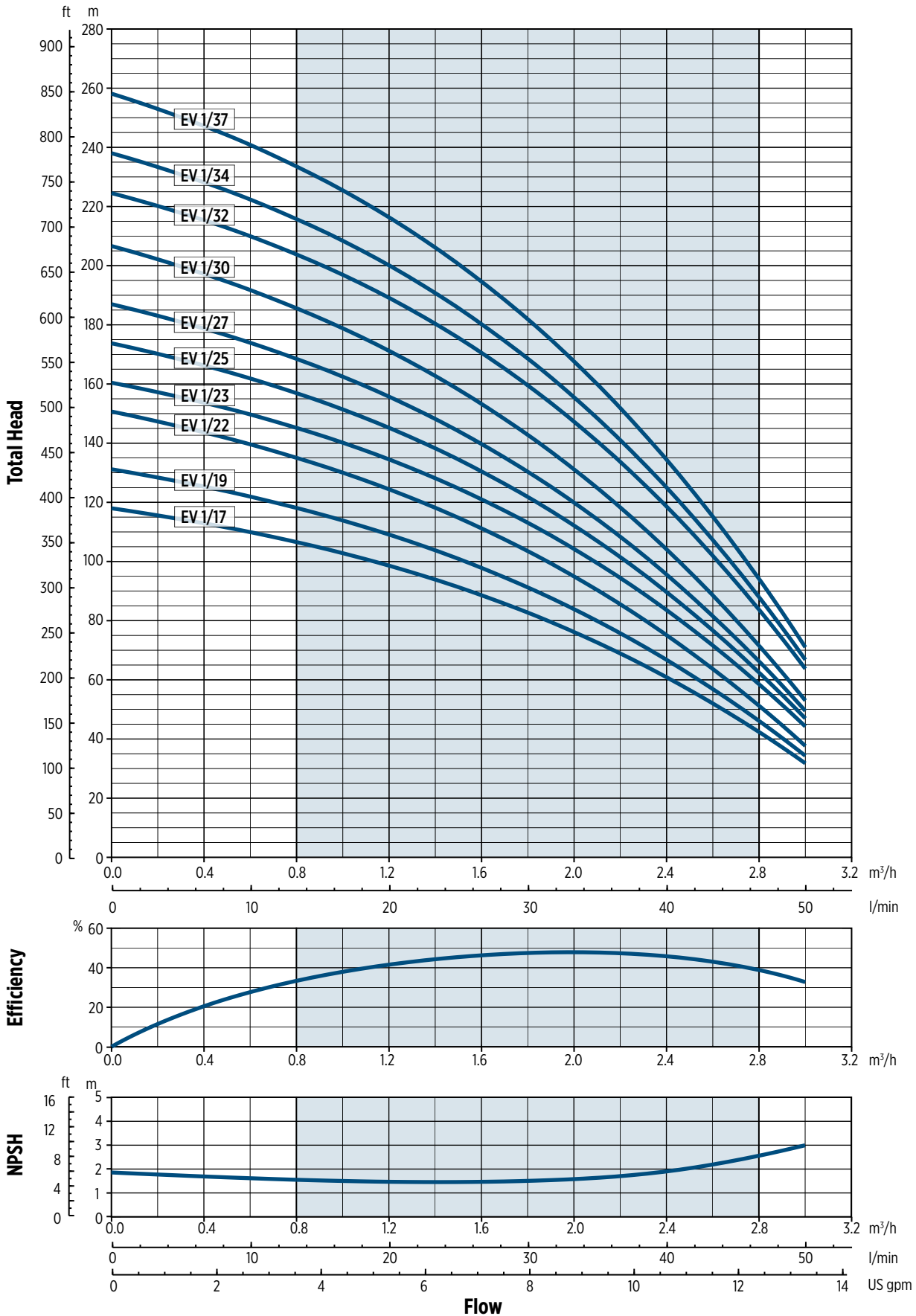

002014BEN02208

The hydraulic characteristics are guaranteed, according to ISO Standard 9906:2012, grade 3B

EV 1 - PERFORMANCE CURVES AT 50 Hz

MEI ≥ 0,70

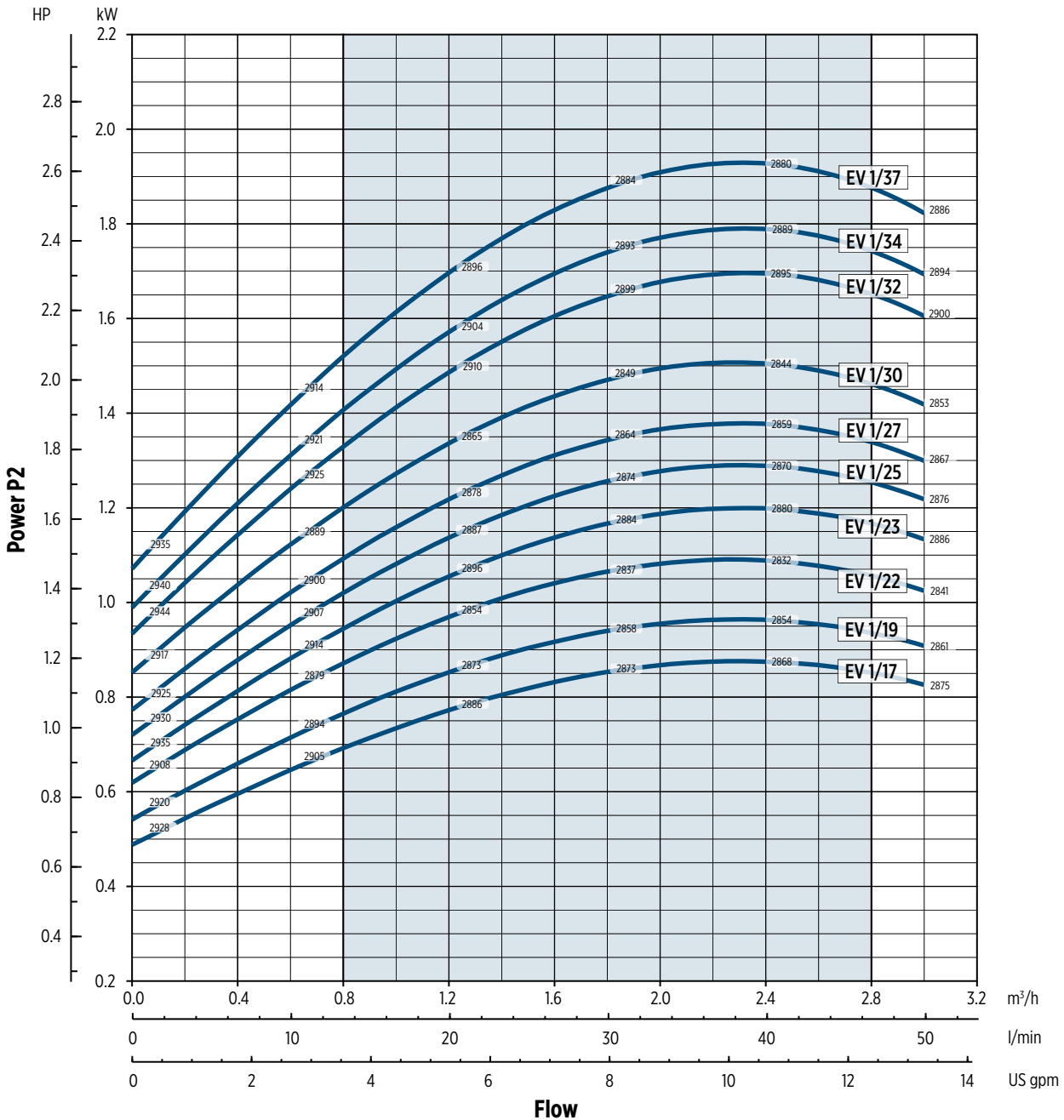

01020114BEN 02/2018

Performance curves of Q, H and P depend on the rpm number according to the following formula:

$$Q_2 = Q_1 \cdot \left(\frac{n_2}{n_1}\right), \quad H_2 = H_1 \cdot \left(\frac{n_2}{n_1}\right)^2, \quad P_2 = P_1 \cdot \left(\frac{n_2}{n_1}\right)^3, \quad \eta \text{ remains approximately the same.}$$

The rpm number related to the performance curves (Q-H-P) is indicated in the power chart.

Performance curves (Q-H-P) will change according to the formulas above.

Q=Capacity, H=Head, P=Power, h=Efficiency



EV 3 - 50 Hz

TECHNICAL DATA

Pump Model	MOTOR		Dimensions [mm]										Weight [kg]				
			L1		L2		L3	L4	L5	M		D1		D2	L1+L2	Pump	Motor
	[kW]	Dim	F	1-PHASE	3-PHASE	T	V	C	1-PHASE	3-PHASE	1-PHASE	3-PHASE					
EV 3/2	0.37	71	313	216	216	288	288	288	134	110	139	139	170	529	11.5	5.8	17.3
EV 3/3	0.37	71	336	216	216	311	311	311	134	110	139	139	170	552	12	5.8	17.8
EV 3/4	0.37	71	358	216	216	333	333	333	134	110	139	139	170	574	12.5	5.8	18.3
EV 3/5	0.55	71	381	216	216	356	356	356	134	110	139	139	170	597	13	6.2	19.2
EV 3/6	0.55	71	403	216	216	378	378	378	134	110	139	139	170	619	13.5	6.2	19.7
EV 3/7	0.75	80	426	232	232	401	401	401	150	129	160	160	170	658	14	9.5	23.5
EV 3/8	0.75	80	448	232	232	423	423	423	150	129	160	160	170	680	14.5	9.5	24
EV 3/9	0.75	80	471	232	232	446	446	446	150	129	160	160	170	703	15	9.5	24.5
EV 3/10	1.1	80	493	232	232	468	468	468	150	129	160	160	170	725	15.5	11.1	26.6
EV 3/11	1.1	80	516	232	232	491	491	491	150	129	160	160	170	748	16	11.1	27.1
EV 3/12	1.1	80	538	232	232	513	513	513	150	129	160	160	170	770	16.5	11.1	27.6
EV 3/13	1.1	80	561	232	232	536	536	536	150	129	160	160	170	793	17	11.1	28.1
EV 3/14	1.5	90	593	267	267	568	568	568	160	138	180	180	170	860	18	14	32
EV 3/15	1.5	90	616	267	267	591	591	591	160	138	180	180	170	883	18.5	14	32.5
EV 3/16	1.5	90	638	267	267	613	613	613	160	138	180	180	170	905	18.5	14	32.5
EV 3/17	1.5	90	661	267	267	636	636	636	160	138	180	180	170	928	19	14	33
EV 3/18	2.2	90	683	267	267	658	658	658	160	138	180	180	170	950	19.5	16	35.5
EV 3/19	2.2	90	706	267	267	681	681	681	160	138	180	180	170	973	20	16	36
EV 3/21	2.2	90	751	267	267	726	726	726	160	138	180	180	170	1018	21	16	37
EV 3/23	2.2	90	796	267	267	-	771	771	160	138	180	180	170	1063	22	16	38
EV 3/25	2.2	90	841	267	267	-	816	816	160	138	180	180	170	1108	23	16	39
EV 3/27	3	100	896	-	306	-	871	871	-	145	-	196	170	1202	24.5	22.8	47.3
EV 3/29	3	100	941	-	306	-	916	916	-	145	-	196	170	1247	25.5	22.8	48.3
EV 3/31	3	100	986	-	306	-	961	961	-	145	-	196	170	1292	26.5	22.8	49.3
EV 3/33	3	100	1031	-	306	-	1006	1006	-	145	-	196	170	1337	27.5	22.8	50.3

DIMENSIONAL DRAWINGS

F Version

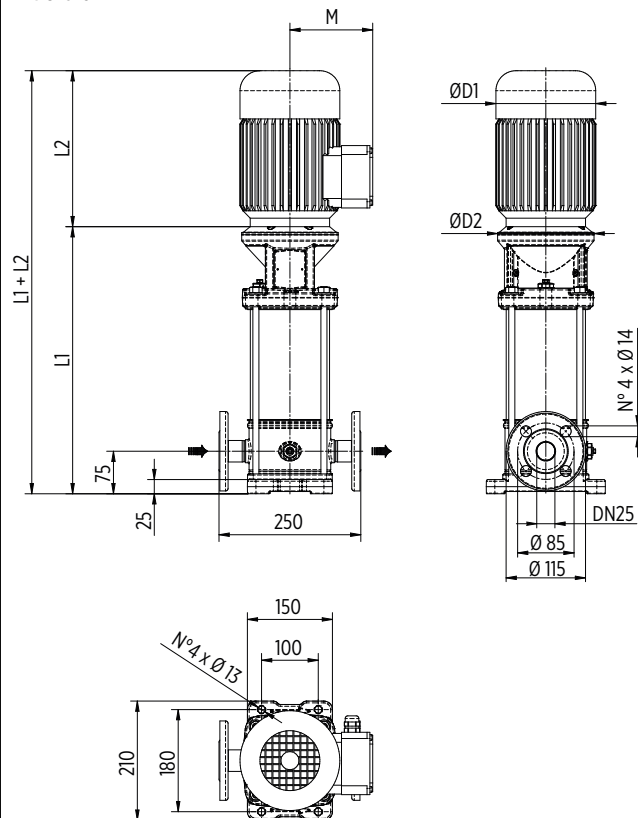

Round flanges on body type PN25: the pump is supplied without counterflanges (Optional accessories, including bolts and joints)

T Version

Available from EV3/2 to EV3/21

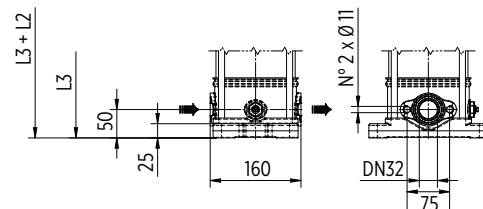

Oval flanges on body type PN16: the pump is supplied without threaded oval counter flanges (Optional accessories, including bolts and joints)

V Version

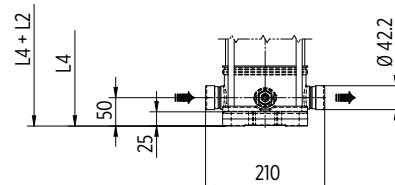

Connections with rapid fittings type "Victaulic": the pump is supplied without the collars (Optional accessories)

C Version

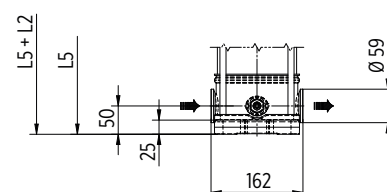

Connections with round fittings type Clamp-FlexiClamp: the pump is supplied without collars (Optional accessories)

00130099EN 02/2018

EV 3 - PERFORMANCE CURVES AT 50 Hz

MEI ≥ 0,70

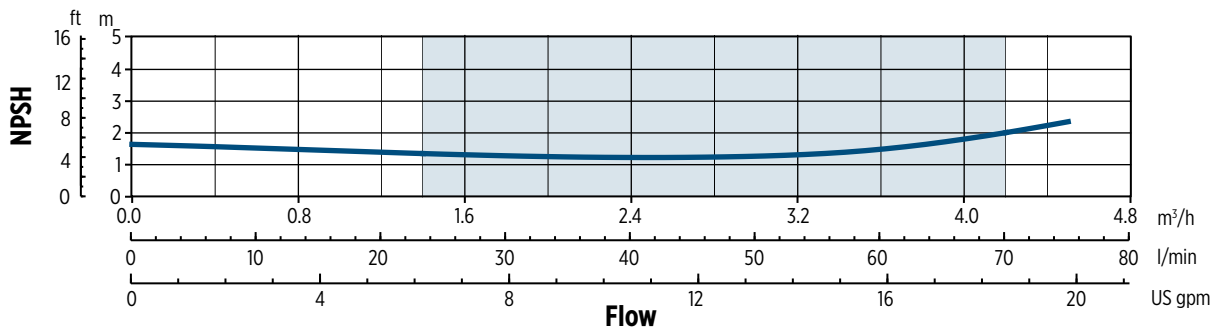
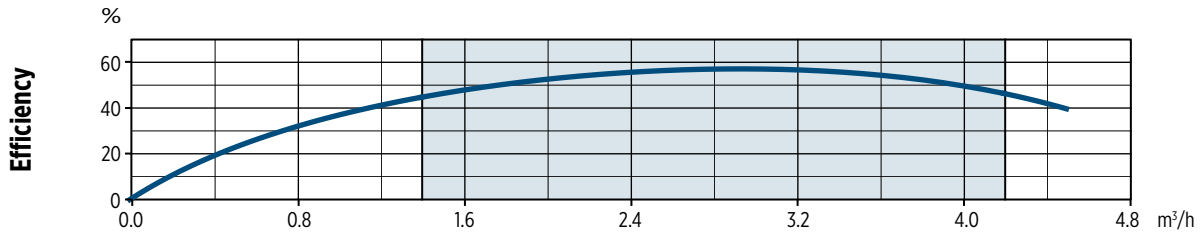
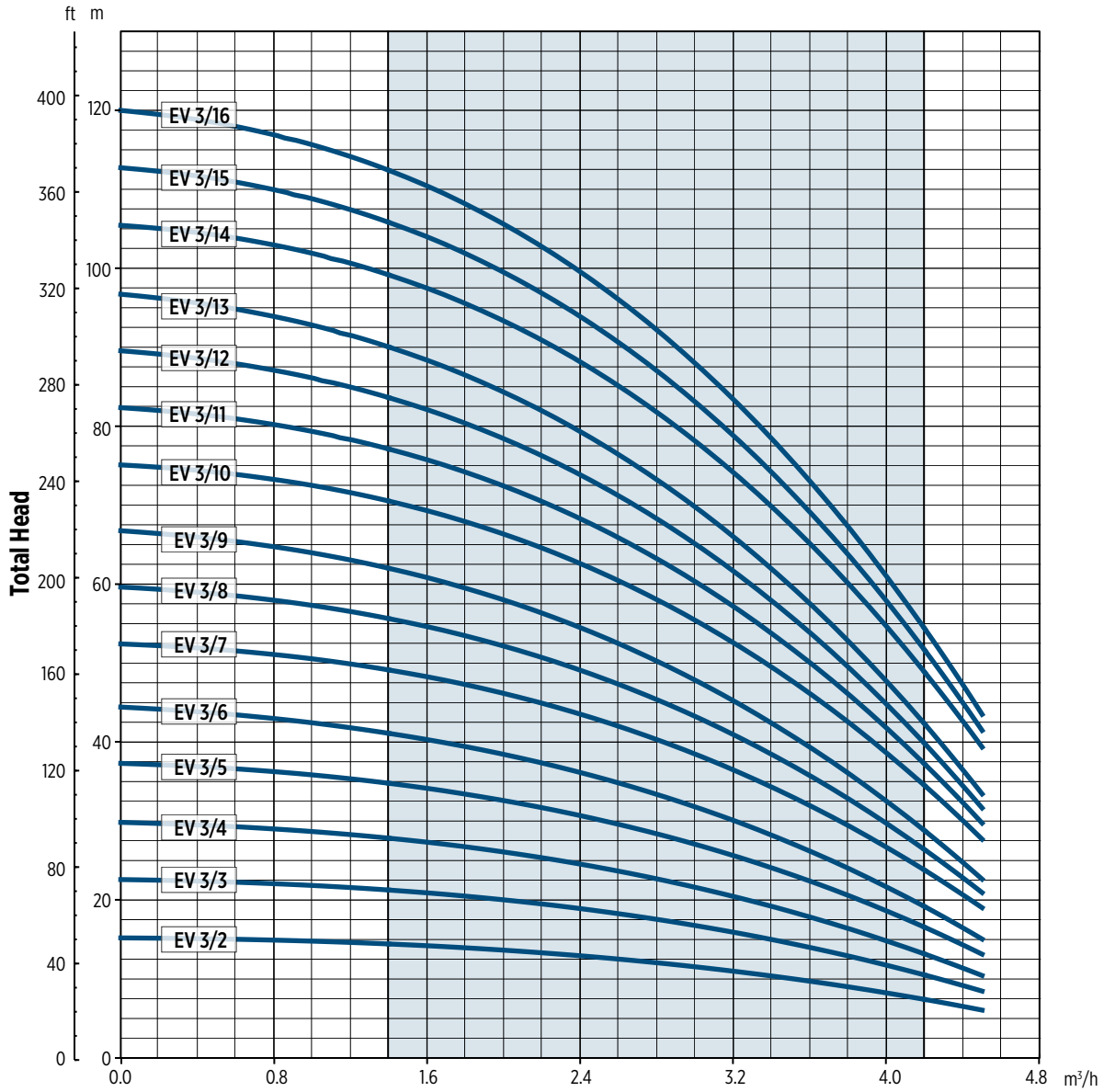

002015AEN 02/2018

The hydraulic characteristics are guaranteed, according to ISO Standard 9906:2012, grade 3B



EV 3 - PERFORMANCE CURVES AT 50 Hz

MEI ≥ 0,70

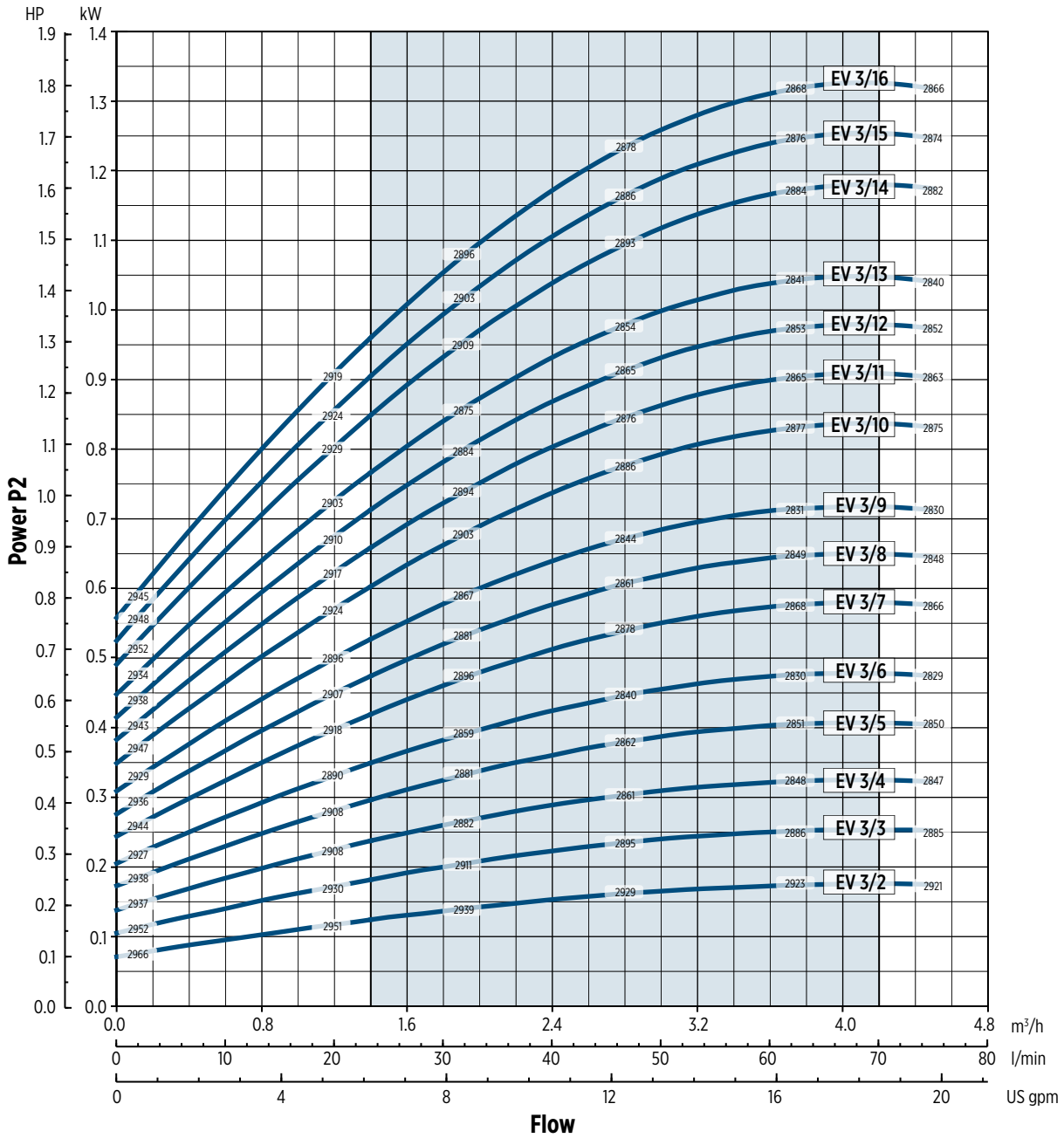

0002015AEN 02/2018

Performance curves of Q, H and P depend on the rpm number according to the following formula:

$$Q_2 = Q_1 \cdot \left(\frac{n_2}{n_1}\right), \quad H_2 = H_1 \cdot \left(\frac{n_2}{n_1}\right)^2, \quad P_2 = P_1 \cdot \left(\frac{n_2}{n_1}\right)^3, \quad \eta \text{ remains approximately the same.}$$

The rpm number related to the performance curves (Q-H-P) is indicated in the power chart.

Performance curves (Q-H-P) will change according to the formulas above.

Q=Capacity, H=Head, P=Power, h=Efficiency

EV 3 - PERFORMANCE CURVES AT 50 Hz

MEI ≥ 0,70

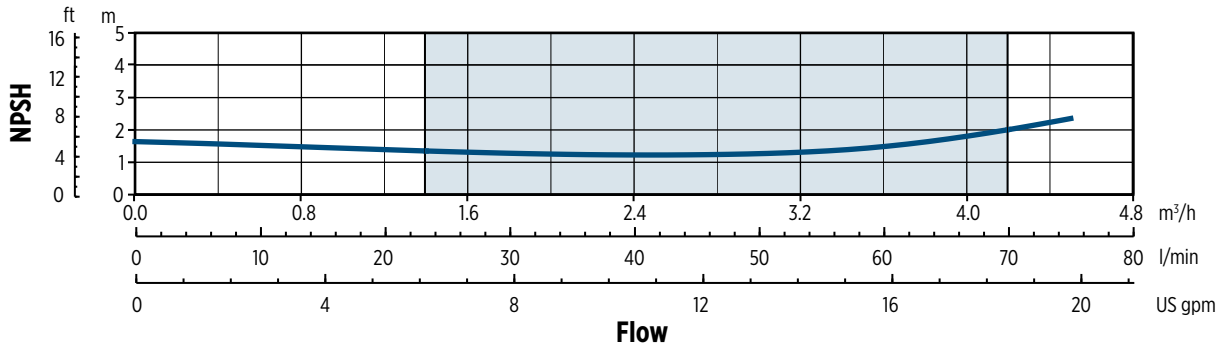
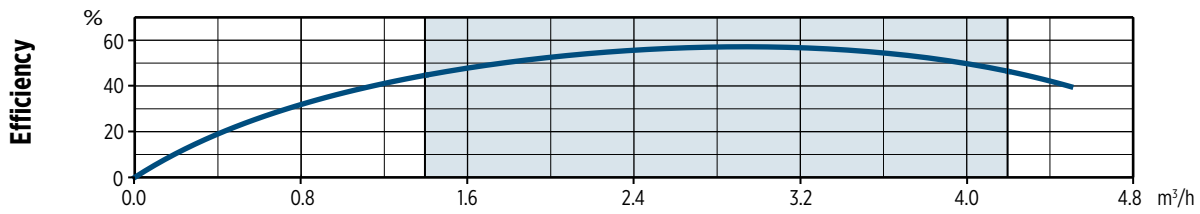
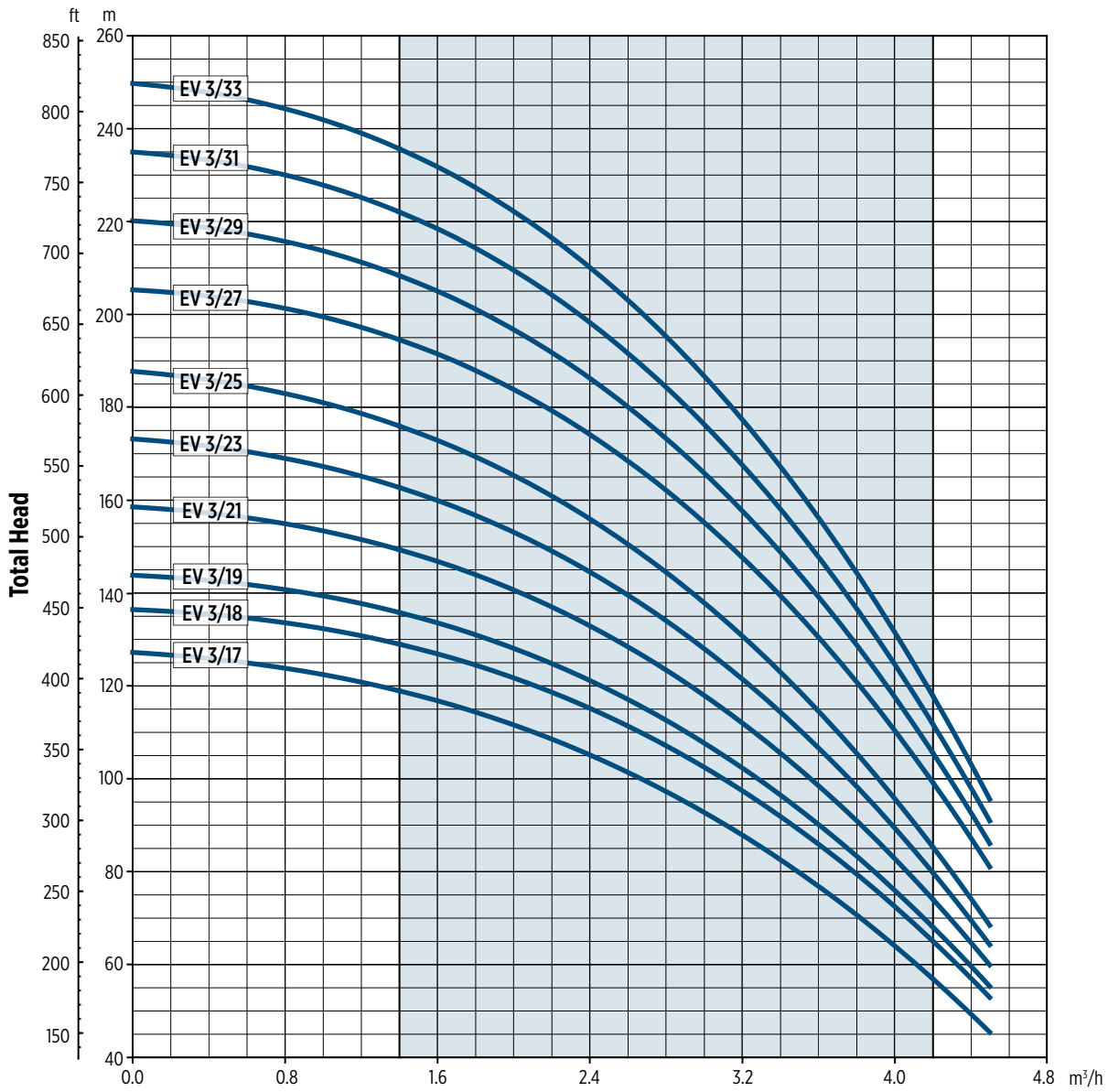

002019BEN 02/2018

The hydraulic characteristics are guaranteed, according to ISO Standard 9906:2012, grade 3B

EV 3 - PERFORMANCE CURVES AT 50 Hz

MEI ≥ 0,70

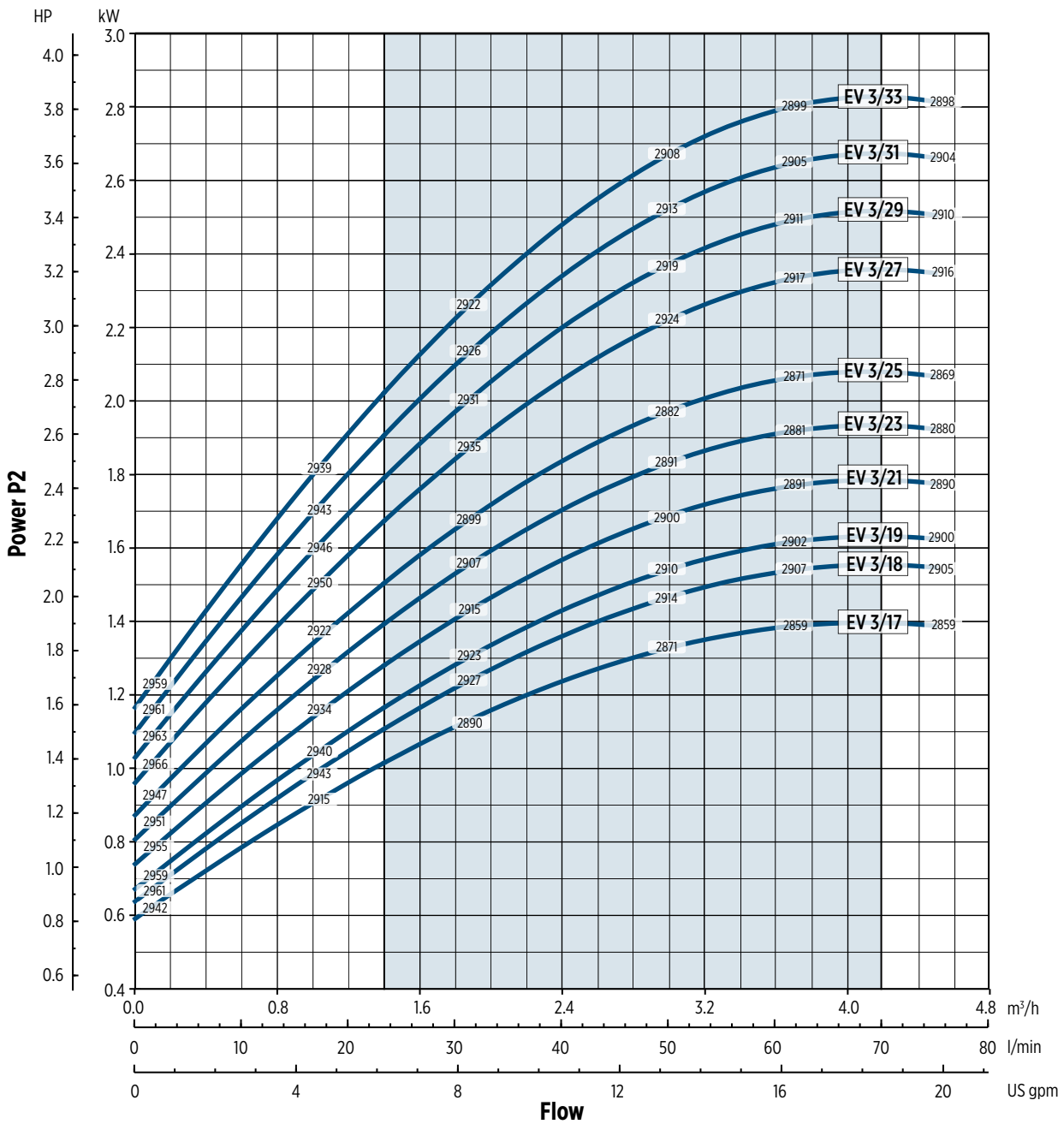

0012015BEN 02/2018

Performance curves of Q, H and P depend on the rpm number according to the following formula:

$$Q_2 = Q_1 \cdot \left(\frac{n_2}{n_1}\right), \quad H_2 = H_1 \cdot \left(\frac{n_2}{n_1}\right)^2, \quad P_2 = P_1 \cdot \left(\frac{n_2}{n_1}\right)^3, \quad \eta \text{ remains approximately the same.}$$

The rpm number related to the performance curves (Q-H-P) is indicated in the power chart.

Performance curves (Q-H-P) will change according to the formulas above.

Q=Capacity, H=Head, P=Power, h=Efficiency

EV 6 - 50 Hz

TECHNICAL DATA

Pump Model	MOTOR		Dimensions [mm]										Weight [kg]				
	[kW]	Dim	L1	L2		L3	L4	L5	M		D1		D2	L1+L2	Pump	Motor	Electric Pump
			F	1-PHASE	3-PHASE	T	V	C	1-PHASE	3-PHASE	1-PHASE	3-PHASE					
EV 6/2	0.37	71	320	216	216	295	295	295	134	110	139	139	170	536	12	5.8	17.8
EV 6/3	0.37	71	346	216	216	321	321	321	134	110	139	139	170	562	12.5	5.8	18.3
EV 6/4	0.55	71	372	216	216	347	347	347	134	110	139	139	170	588	13	6.2	19.2
EV 6/5	0.75	80	398	232	232	373	373	373	150	129	160	160	170	630	13.5	9.5	23
EV 6/6	0.75	80	424	232	232	399	399	399	150	129	160	160	170	656	14	9.5	23.5
EV 6/7	1.1	80	450	232	232	425	425	425	150	129	160	160	170	682	14.5	11.1	25.6
EV 6/8	1.1	80	476	232	232	451	451	451	150	129	160	160	170	708	15	11.1	26.1
EV 6/9	1.1	80	502	232	232	477	477	477	150	129	160	160	170	734	15.5	11.1	26.6
EV 6/10	1.5	90	538	267	267	513	513	513	160	138	180	180	170	805	16.5	14	30.5
EV 6/11	1.5	90	564	267	267	539	539	539	160	138	180	180	170	831	17.5	14	31.5
EV 6/12	1.5	90	590	267	267	565	565	565	160	138	180	180	170	857	18	14	32
EV 6/13	1.5	90	616	267	267	591	591	591	160	138	180	180	170	883	18.5	14	32.5
EV 6/14	2.2	90	642	267	267	617	617	617	160	138	180	180	170	909	19	16	35
EV 6/15	2.2	90	668	267	267	643	643	643	160	138	180	180	170	935	19.5	16	35.5
EV 6/16	2.2	90	694	267	267	669	669	669	160	138	180	180	170	961	20	16	36
EV 6/17	2.2	90	720	267	267	695	695	695	160	138	180	180	170	987	20.5	16	36.5
EV 6/18	2.2	90	746	267	267	721	721	721	160	138	180	180	170	1013	21	16	37
EV 6/19	2.2	90	772	267	267	747	747	747	160	138	180	180	170	1039	21.5	16	37.5
EV 6/20	3	100	808	-	306	783	783	783	-	145	-	196	170	1114	22.5	22.8	45.3
EV 6/21	3	100	834	-	306	809	809	809	-	145	-	196	170	1140	23	22.8	45.8
EV 6/23	3	100	886	-	306	-	861	861	-	145	-	196	170	1192	24	22.8	46.8
EV 6/25	3	100	938	-	306	-	913	913	-	145	-	196	170	1244	25	22.8	47.8
EV 6/28	4	112	1016	-	306	-	991	991	-	145	-	196	170	1322	26.5	26.5	53
EV 6/30	4	112	1068	-	306	-	1043	1043	-	145	-	196	170	1374	28	26.5	54.5
EV 6/33	4	112	1146	-	306	-	1121	1121	-	145	-	196	170	1452	29.5	26.5	56
EV 6/36*	5.5	132	1400	-	328	-	1375	1375	-	160	-	225	300	1728	50.5	33.6	84.1

* EV 6/36 available only with Victaulic® connections

DIMENSIONAL DRAWINGS

F Version

Round flanges on body type PN25: the pump is supplied without counterflanges (Optional accessories, including bolts and joints)

T Version

Available from EV6/2 to EV6/21

Oval flanges on body type PN16: the pump is supplied without threaded oval counter flanges (Optional accessories, including bolts and joints)

V Version

Connections with rapid fittings type "Victaulic": the pump is supplied without the collars (Optional accessories)

C Version

Connections with round fittings type Clamp-FlexiClamp: the pump is supplied without collars (Optional accessories)

EV 6 - PERFORMANCE CURVES AT 50 Hz

MEI ≥ 0,70

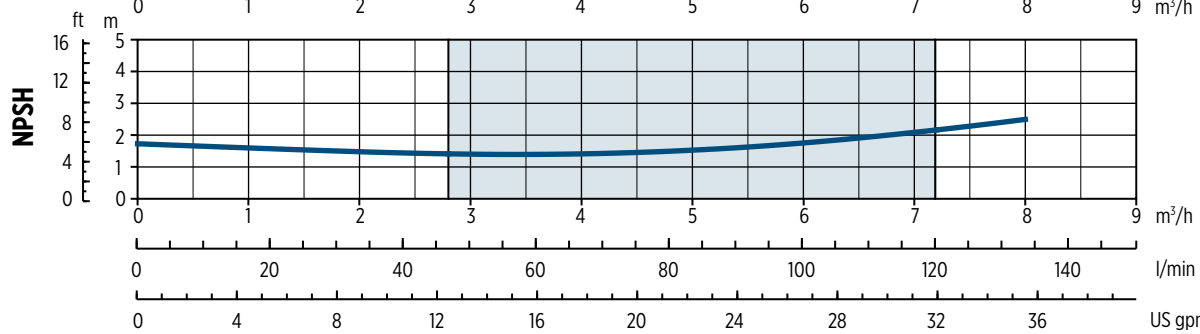
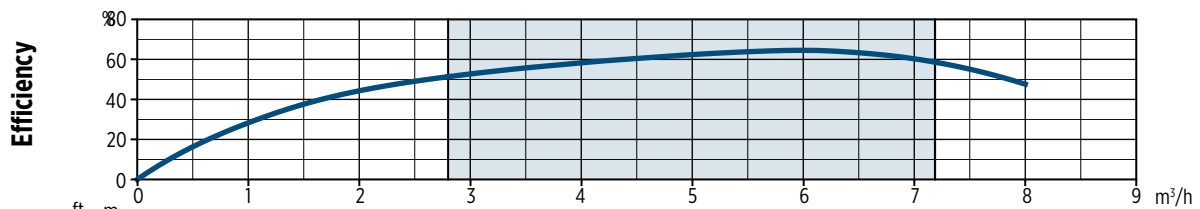
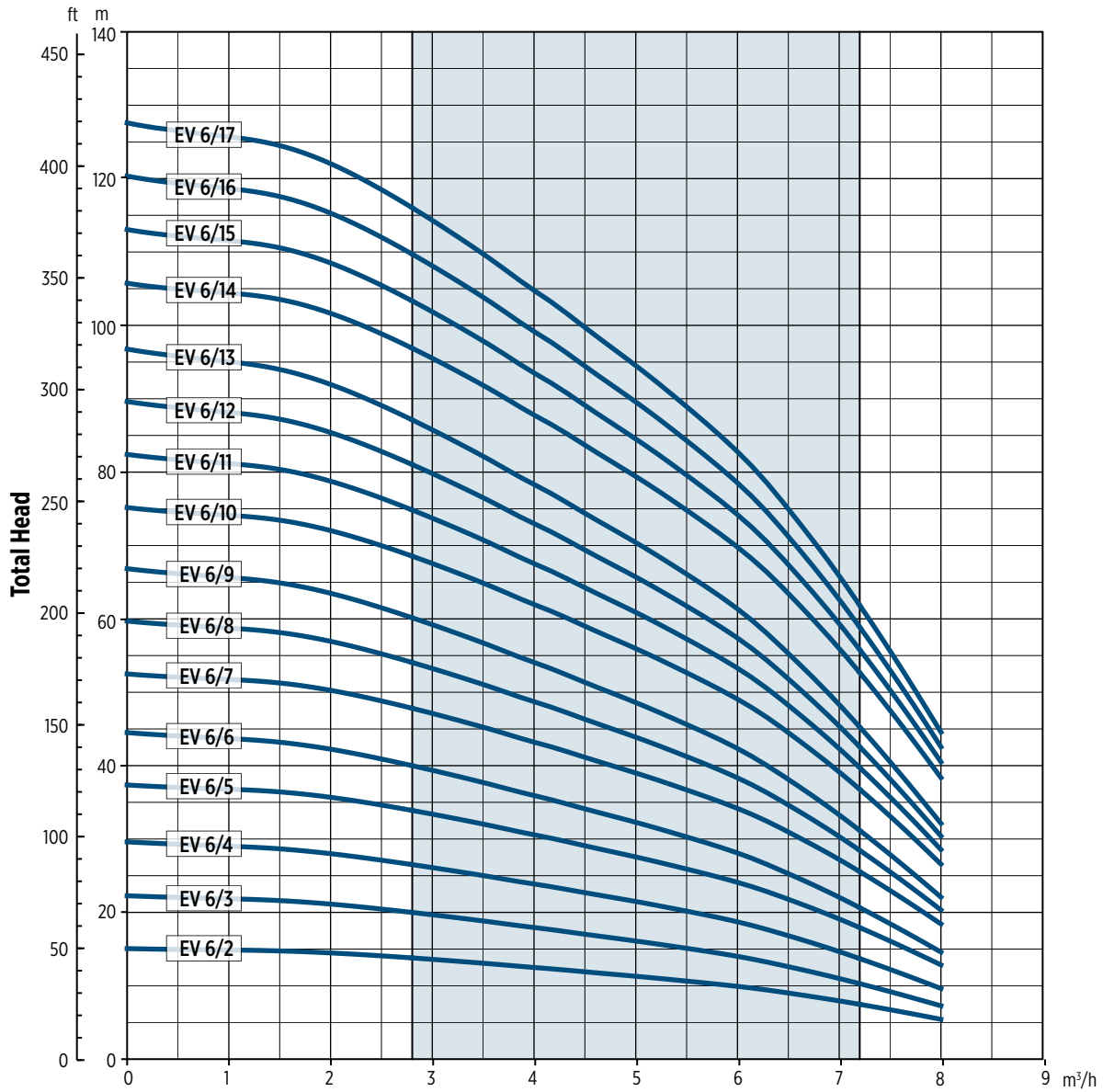

0022016AEN 02/2018

The hydraulic characteristics are guaranteed, according to ISO Standard 9906:2012, grade 3B

EV 6 - PERFORMANCE CURVES AT 50 Hz

MEI ≥ 0,70

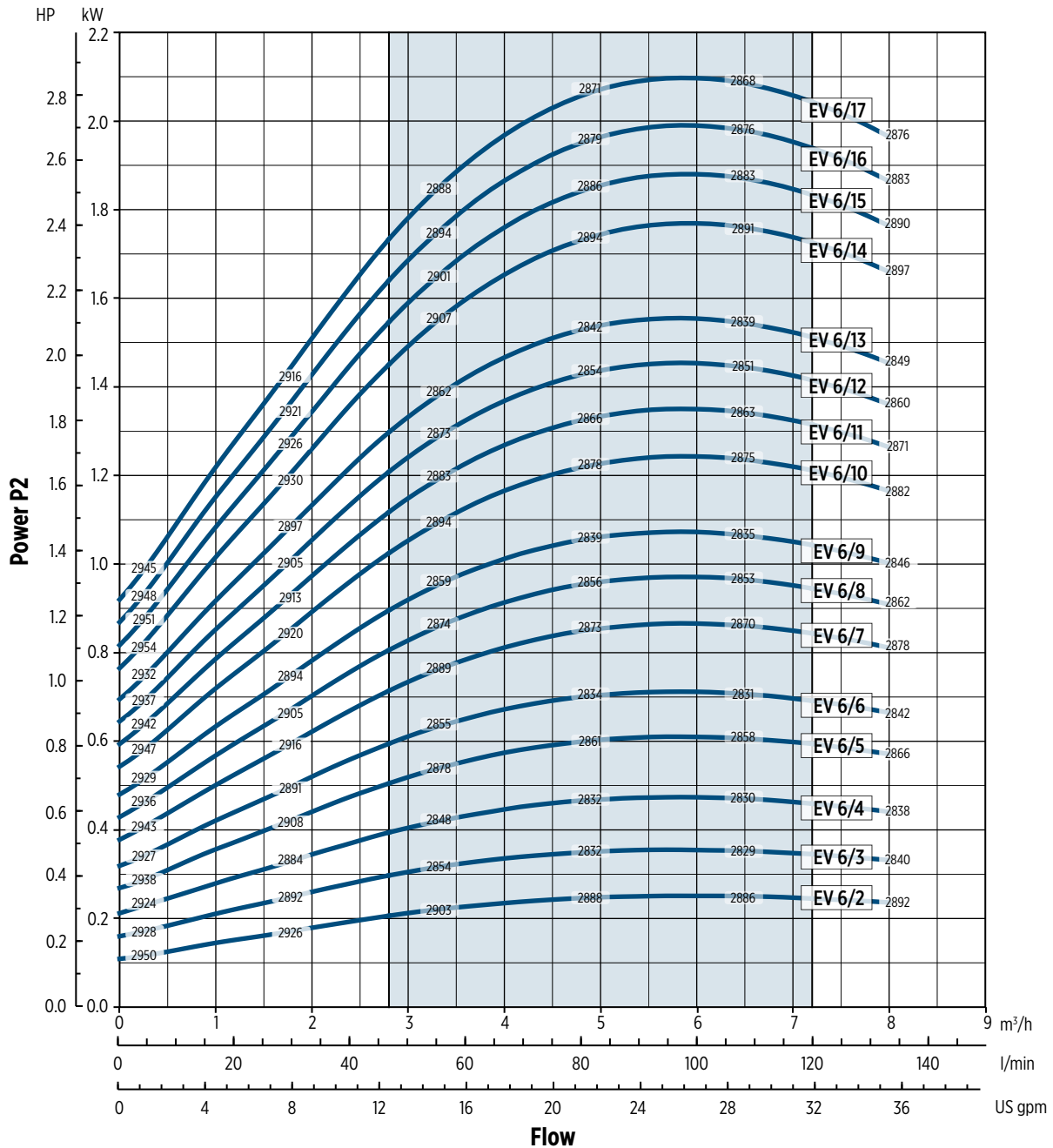

002016AEN 02/2018

Performance curves of Q, H and P depend on the rpm number according to the following formula:

$$Q_2 = Q_1 \cdot \left(\frac{n_2}{n_1}\right), \quad H_2 = H_1 \cdot \left(\frac{n_2}{n_1}\right)^2, \quad P_2 = P_1 \cdot \left(\frac{n_2}{n_1}\right)^3, \quad \eta \text{ remains approximately the same.}$$

The rpm number related to the performance curves (Q-H-P) is indicated in the power chart.

Performance curves (Q-H-P) will change according to the formulas above.

Q=Capacity, H=Head, P=Power, h=Efficiency

EV 6 - PERFORMANCE CURVES AT 50 Hz

MEI ≥ 0,70

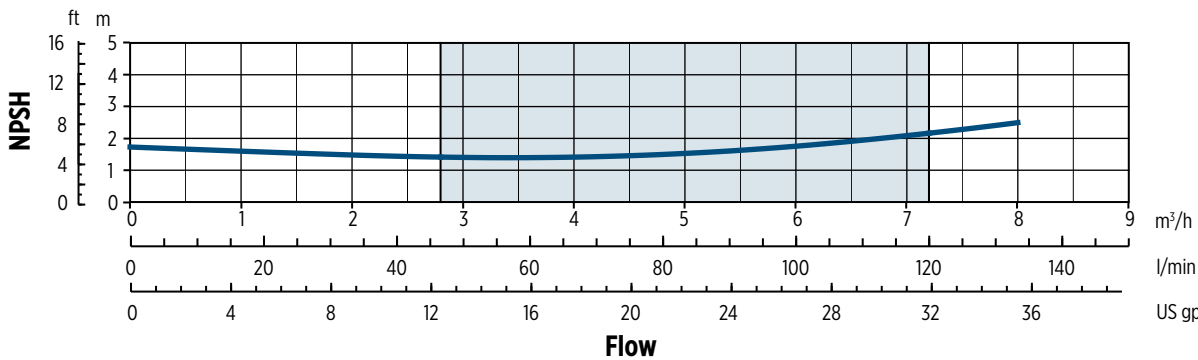
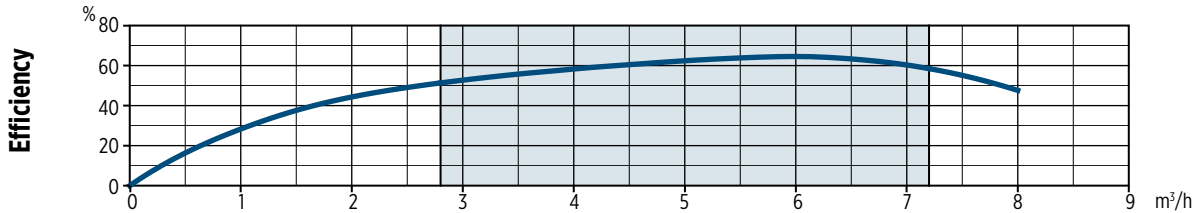
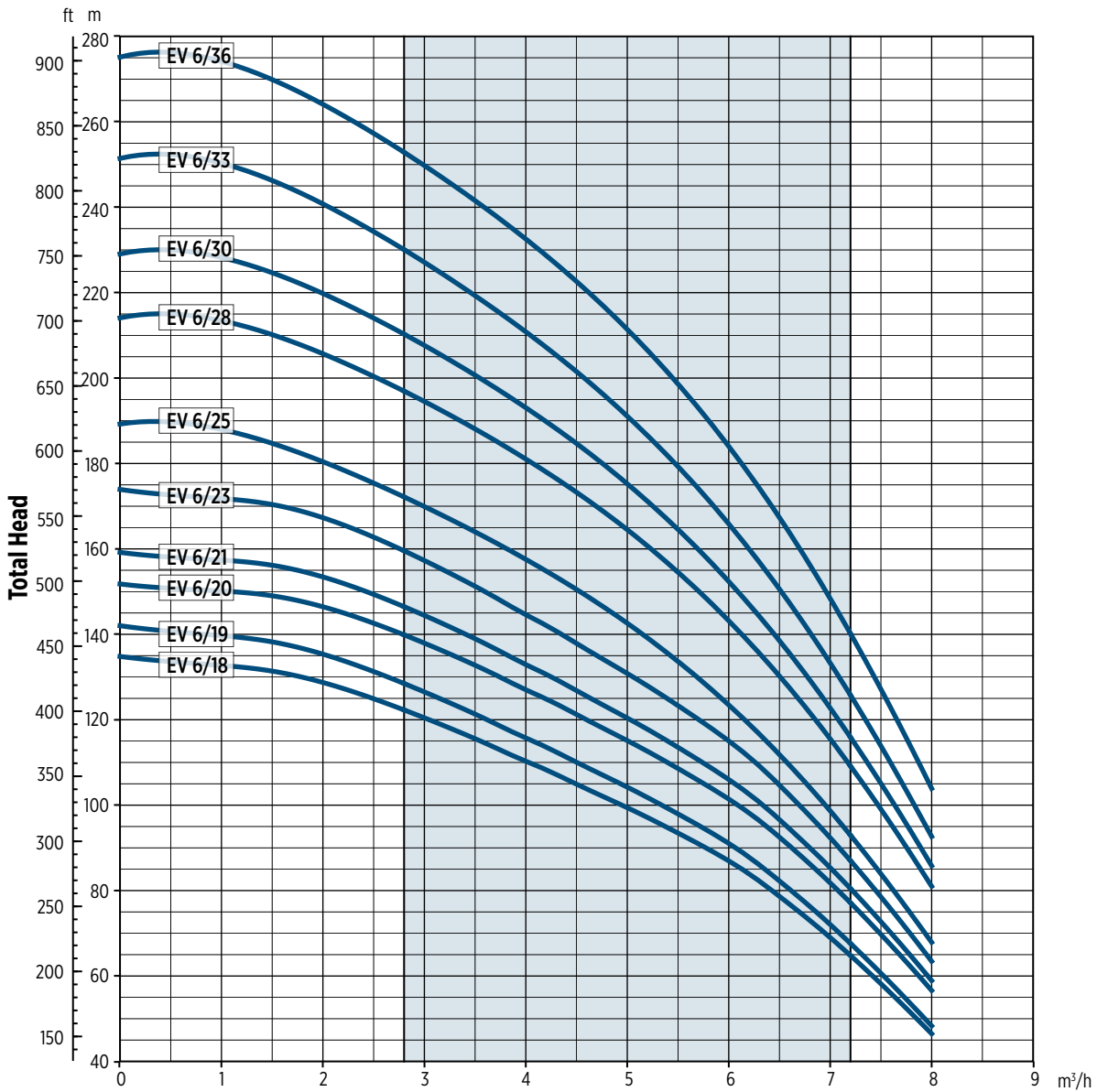

002016BEN 02/2018

The hydraulic characteristics are guaranteed, according to ISO Standard 9906:2012, grade 3B

EV 6 - PERFORMANCE CURVES AT 50 Hz

MEI ≥ 0,70

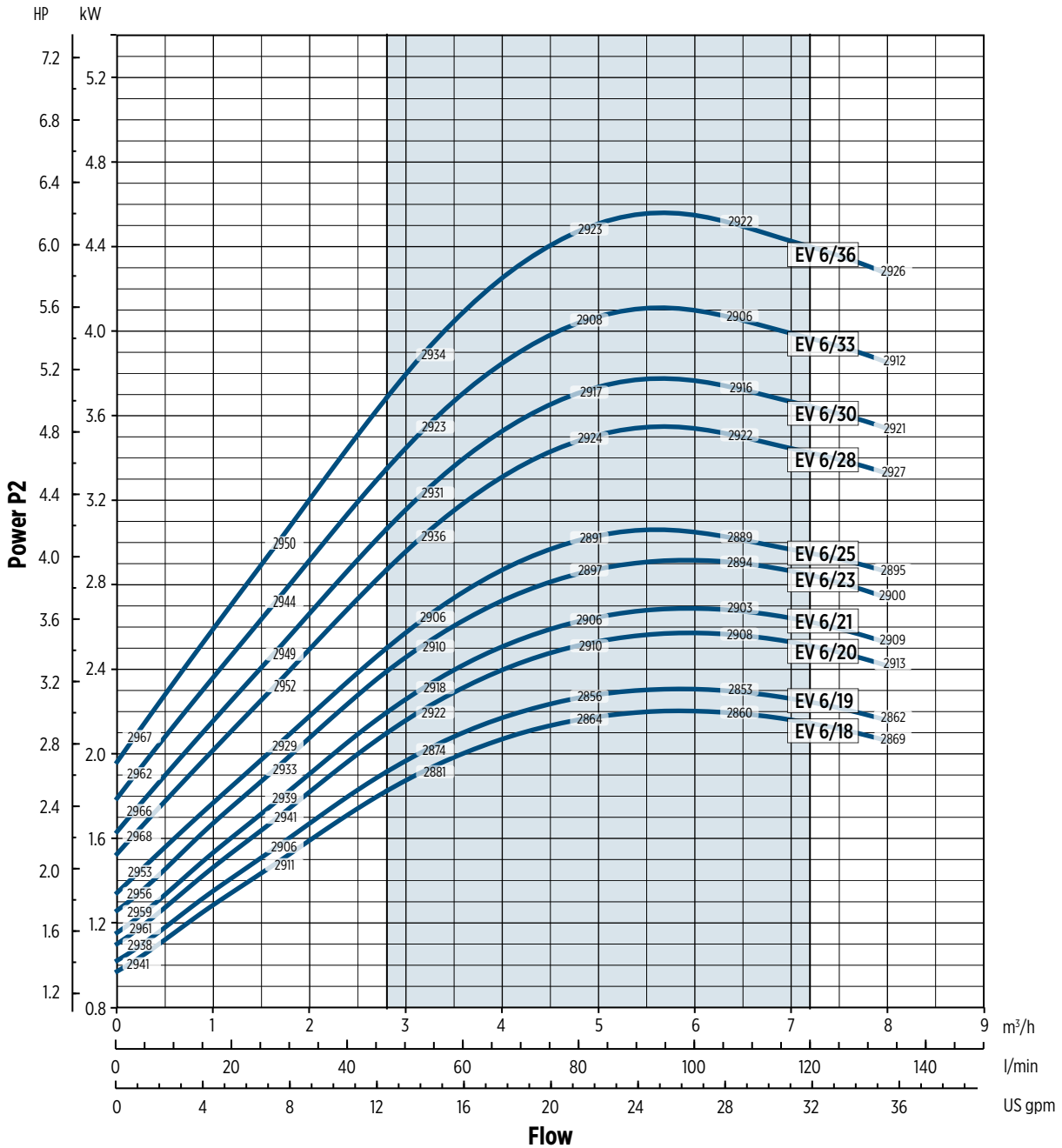

002016BEN 02/2018

Performance curves of Q, H and P depend on the rpm number according to the following formula:

$$Q_2 = Q_1 \cdot \left(\frac{n_2}{n_1}\right), \quad H_2 = H_1 \cdot \left(\frac{n_2}{n_1}\right)^2, \quad P_2 = P_1 \cdot \left(\frac{n_2}{n_1}\right)^3, \quad \eta \text{ remains approximately the same.}$$

The rpm number related to the performance curves (Q-H-P) is indicated in the power chart.

Performance curves (Q-H-P) will change according to the formulas above.

Q=Capacity, H=Head, P=Power, h=Efficiency



EV 10 - 50 Hz

TECHNICAL DATA

Pump Model	MOTOR		Dimensions [mm]													Weight [kg]		
			L1		L2		L3	L4		L5	M		D1		D2	L1+L2	Pump	Motor
	[kW]	Dim	F	1-PHASE	3-PHASE	T	V	C	1-PHASE	3-PHASE	1-PHASE	3-PHASE						
EV 10/2	0.75	80	341	232	232	341	341	341	150	129	160	160	170	573	13	9.5	22.5	
EV 10/3	1.1	80	371	232	232	371	371	371	150	129	160	160	170	603	14	11.1	25.1	
EV 10/4	1.5	90	411	267	267	411	411	411	160	138	180	180	170	678	15	14	29	
EV 10/5	1.5	90	441	267	267	441	441	441	160	138	180	180	170	708	15.5	14	29.5	
EV 10/6	2.2	90	471	267	267	471	471	471	160	138	180	180	170	738	16.5	16	32.5	
EV 10/7	2.2	90	501	267	267	501	501	501	160	138	180	180	170	768	17	16	33	
EV 10/8	3	100	541	-	306	541	541	541	-	145	-	196	170	847	18.5	22.8	41.3	
EV 10/9	3	100	571	-	306	571	571	571	-	145	-	196	170	877	19	22.8	41.8	
EV 10/10	4	112	601	-	306	601	601	601	-	145	-	196	170	907	19.5	26.5	46	
EV 10/11	4	112	631	-	306	631	631	631	-	145	-	196	170	937	20	26.5	46.5	
EV 10/12	4	112	661	-	306	661	661	661	-	145	-	196	170	967	21	26.5	47.5	
EV 10/13	4	112	691	-	306	691	691	691	-	145	-	196	170	997	21.5	26.5	48	
EV 10/15	5.5	132	926	-	328	926	926	926	-	160	-	225	300	1254	42.5	33.6	76.1	
EV 10/17	5.5	132	986	-	328	-	986	986	-	160	-	225	300	1314	43.5	33.6	77.1	
EV 10/19	7.5	132	1046	-	350	-	1046	1046	-	160	-	225	300	1396	45	36	81	
EV 10/21	7.5	132	1106	-	350	-	1106	1106	-	160	-	225	300	1456	46.5	36	82.5	
EV 10/23	7.5	132	1166	-	350	-	1166	1166	-	160	-	225	300	1516	47.5	36	83.5	
EV 10/24	11	160	1216	-	425	-	1216	1216	-	194	-	248	350	1641	50.5	59	109.5	

DIMENSIONAL DRAWINGS

F Version

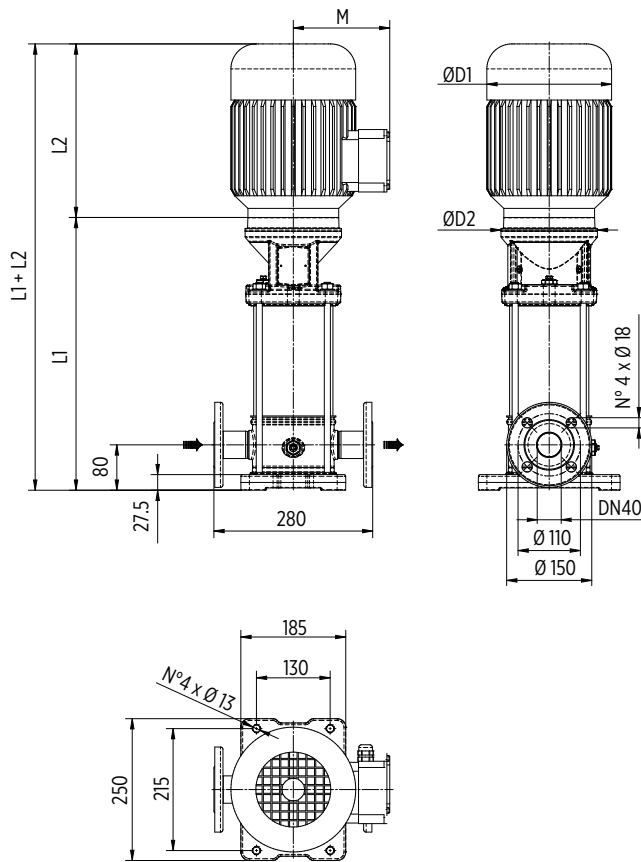

Round flanges on body type PN25: the pump is supplied without counterflanges (Optional accessories, including bolts and joints)

T Version

Available from EV10/2 to EV10/15

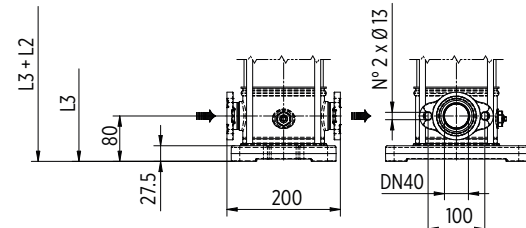

Oval flanges on body type PN16: the pump is supplied without threaded oval counter flanges (Optional accessories, including bolts and joints)

V Version

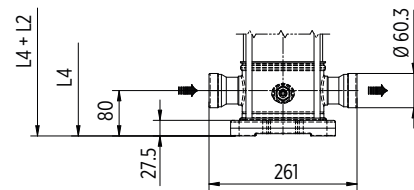

Connections with rapid fittings type "Victaulic": the pump is supplied without the collars (Optional accessories)

C Version

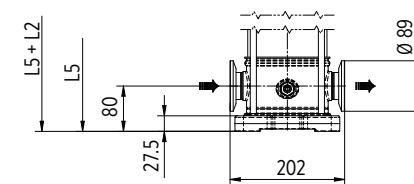

Connections with round fittings type Clamp-FlexiClamp: the pump is supplied without collars (Optional accessories)

00130101EN 02/2018

EV 10 - PERFORMANCE CURVES AT 50 Hz

MEI ≥ 0,70

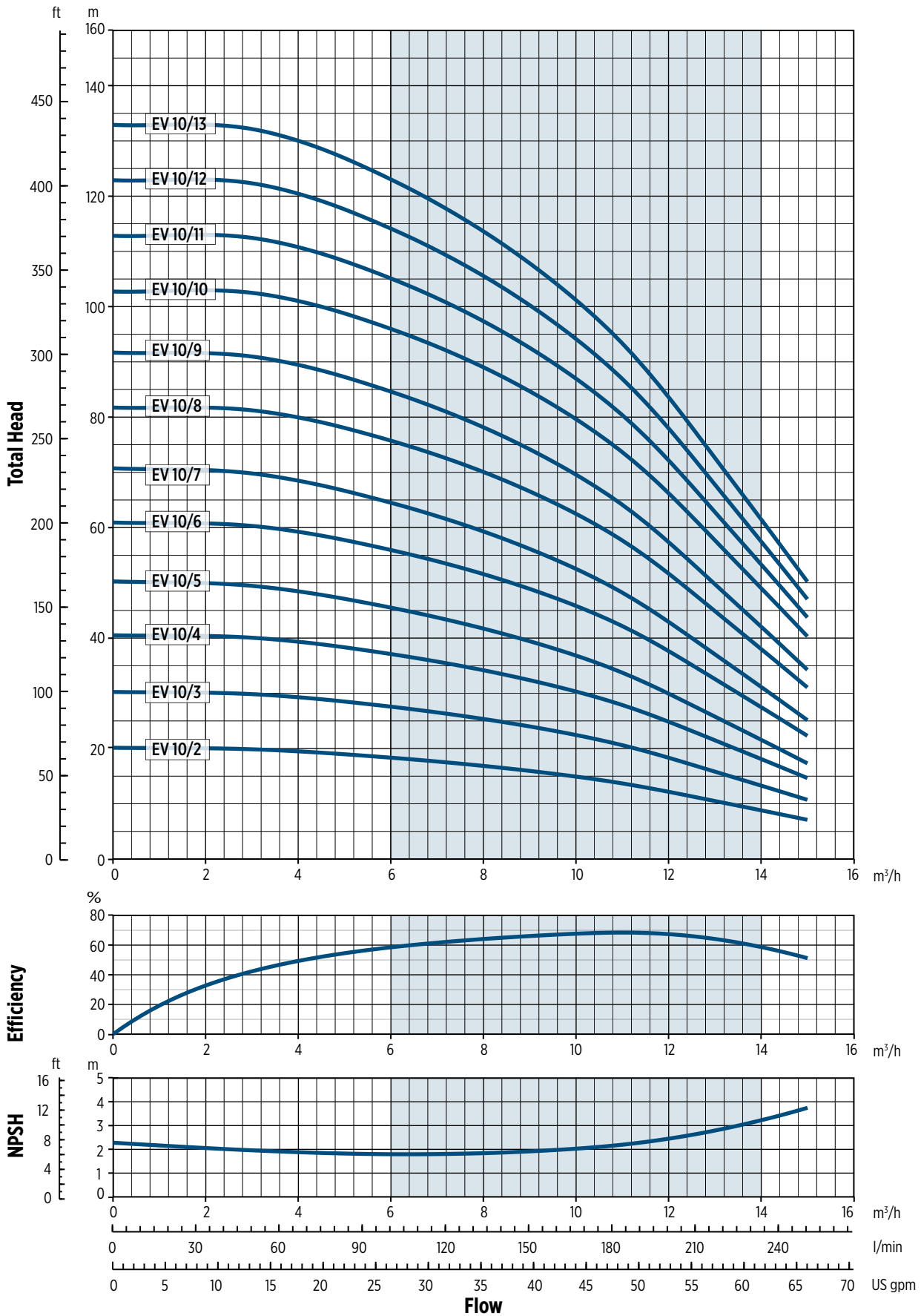

0020077AEN 02/2018

The hydraulic characteristics are guaranteed, according to ISO Standard 9906:2012, grade 3B



EV 10 - PERFORMANCE CURVES AT 50 Hz

MEI ≥ 0,70

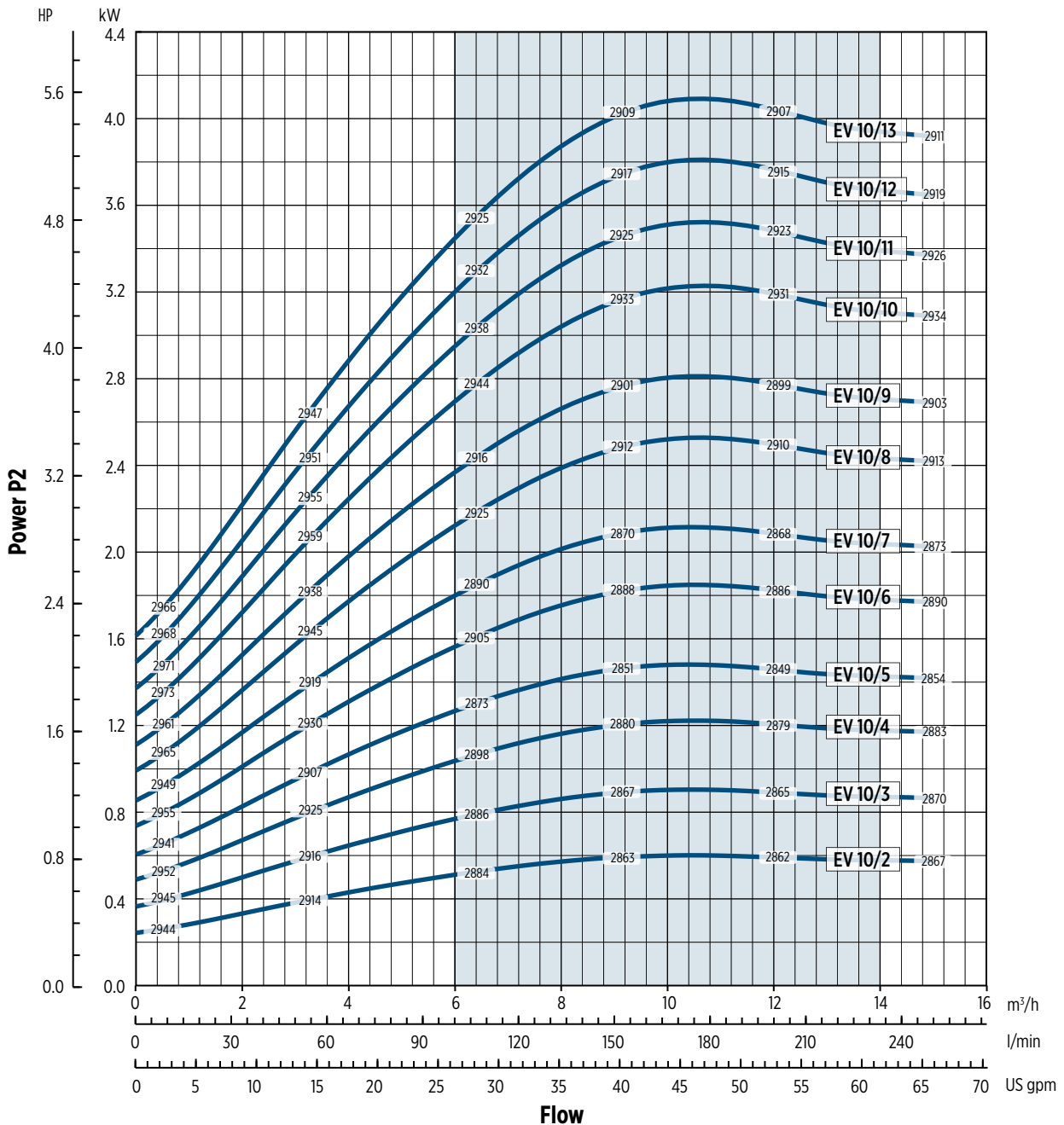

0002017A/EN 02/2018

Performance curves of Q, H and P depend on the rpm number according to the following formula:

$$Q_2 = Q_1 \cdot \left(\frac{n_2}{n_1}\right), \quad H_2 = H_1 \cdot \left(\frac{n_2}{n_1}\right)^2, \quad P_2 = P_1 \cdot \left(\frac{n_2}{n_1}\right)^3, \quad \eta \text{ remains approximately the same.}$$

The rpm number related to the performance curves (Q-H-P) is indicated in the power chart.

Performance curves (Q-H-P) will change according to the formulas above.

Q=Capacity, H=Head, P=Power, h=Efficiency

EV 10 - PERFORMANCE CURVES AT 50 Hz

MEI ≥ 0,70

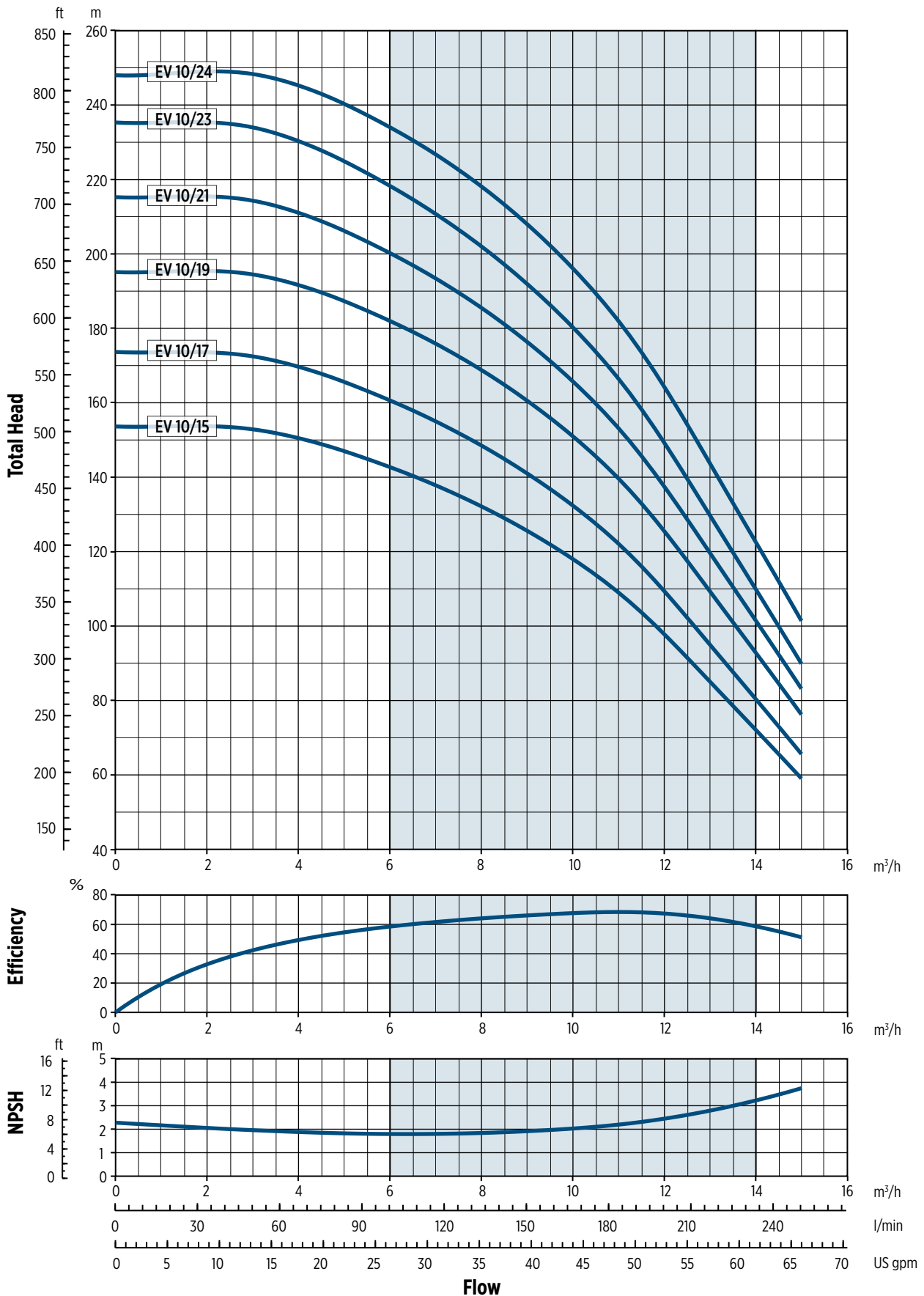

0012017BEN 02/2018

The hydraulic characteristics are guaranteed, according to ISO Standard 9906:2012, grade 3B



EV 10 - PERFORMANCE CURVES AT 50 Hz

MEI ≥ 0,70

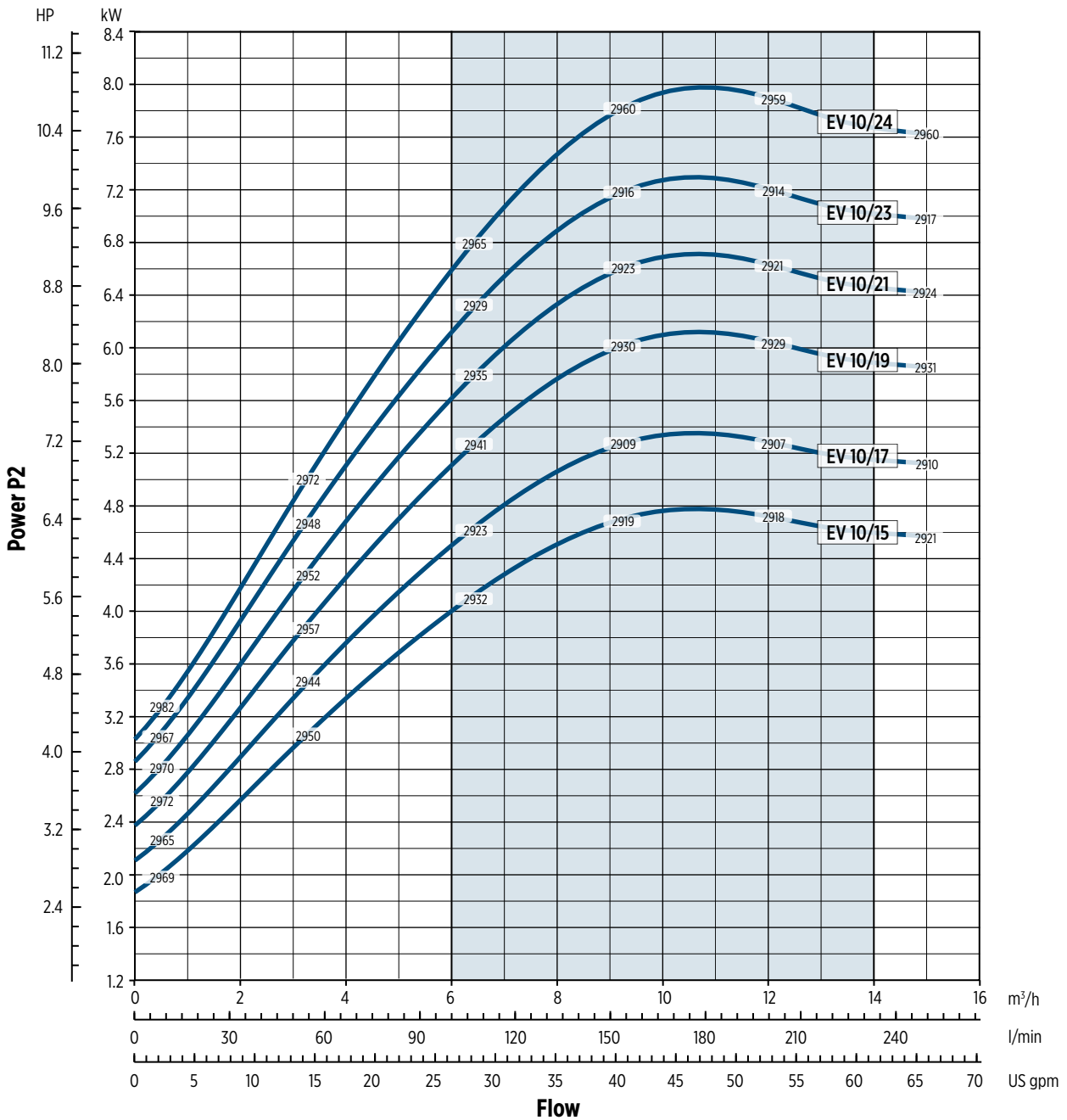

0012017BEN 02/2018

Performance curves of Q, H and P depend on the rpm number according to the following formula:

$$Q_2 = Q_1 \cdot \left(\frac{n_2}{n_1}\right), \quad H_2 = H_1 \cdot \left(\frac{n_2}{n_1}\right)^2, \quad P_2 = P_1 \cdot \left(\frac{n_2}{n_1}\right)^3, \quad \eta \text{ remains approximately the same.}$$

The rpm number related to the performance curves (Q-H-P) is indicated in the power chart.

Performance curves (Q-H-P) will change according to the formulas above.

Q=Capacity, H=Head, P=Power, h=Efficiency



EV 15 - 50 Hz

TECHNICAL DATA

Pump Model	MOTOR		Dimensions [mm]										Weight [kg]				
			L1		L2		L3	L4	L5	M		D1		D2	L1+L2	Pump	Motor
	[kW]	Dim	F	1-PHASE	3-PHASE	T	V	C	1-PHASE	3-PHASE	1-PHASE	3-PHASE					
EV 15/1	1.1	80	401	232	232	401	401	401	150	129	160	160	170	633	19.5	11.1	30.6
EV 15/2	2.2	90	411	267	267	411	411	411	160	138	180	180	170	678	21	16	37
EV 15/3	3	100	469	-	306	469	469	469	-	145	-	196	170	775	23	22.8	45.8
EV 15/4	4	112	517	-	306	517	517	517	-	145	-	196	170	823	24.5	26.5	51
EV 15/5	4	112	565	-	306	565	565	565	-	145	-	196	170	871	26	26.5	52.5
EV 15/6	5.5	132	800	-	328	800	800	800	-	160	-	225	300	1128	47.5	33.6	81.1
EV 15/7	5.5	132	848	-	328	848	848	848	-	160	-	225	300	1176	49	33.6	82.6
EV 15/8	7.5	132	896	-	350	896	896	896	-	160	-	225	300	1246	50.5	36	86.5
EV 15/9	7.5	132	944	-	350	944	944	944	-	160	-	225	300	1294	52	36	88
EV 15/10	11	160	1012	-	425	1012	1012	1012	-	194	-	248	350	1437	56	59	115
EV 15/11	11	160	1060	-	425	-	1060	1060	-	194	-	248	350	1485	57.5	59	116.5
EV 15/12	11	160	1108	-	425	-	1108	1108	-	194	-	248	350	1533	59	59	118
EV 15/13	11	160	1156	-	425	-	1156	1156	-	194	-	248	350	1581	60.5	59	119.5
EV 15/14	11	160	1204	-	425	-	1204	1204	-	194	-	248	350	1629	62	59	121
EV 15/15	15	160	1252	-	476	-	1252	1252	-	194	-	248	350	1728	63	68	131
EV 15/16	15	160	1300	-	476	-	1300	1300	-	194	-	248	350	1776	64.5	68	132.5
EV 15/17	15	160	1348	-	476	-	1348	1348	-	194	-	248	350	1824	66	68	134

DIMENSIONAL DRAWINGS

F Version

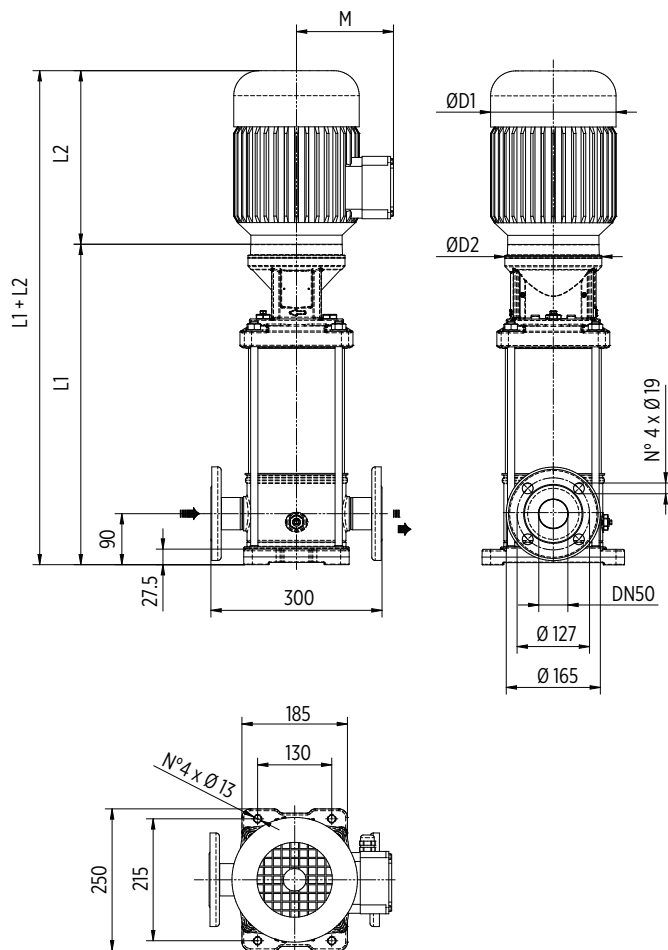

Round flanges on body type PN25: the pump is supplied without counterflanges (Optional accessories, including bolts and joints)

T Version

Available from EV15/1 to EV15/10

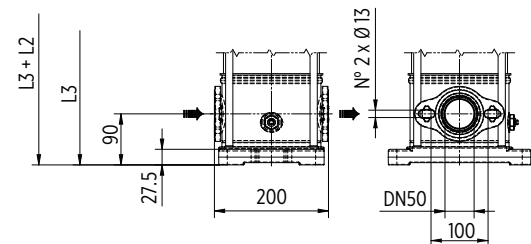

Oval flanges on body type PN16: the pump is supplied without threaded oval counter flanges (Optional accessories, including bolts and joints)

V Version

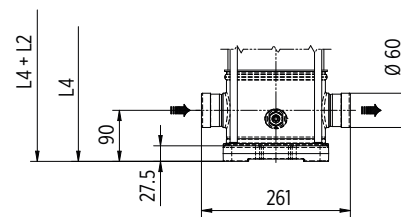

Connections with rapid fittings type "Victaulic": the pump is supplied without the collars (Optional accessories)

C Version

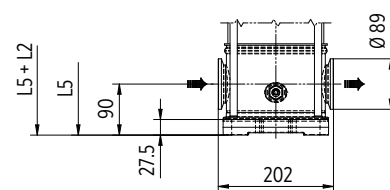

Connections with round fittings type Clamp-FlexiClamp: the pump is supplied without collars (Optional accessories)

0013002EN 02/2018

EV 15 - PERFORMANCE CURVES AT 50 Hz

MEI ≥ 0,70

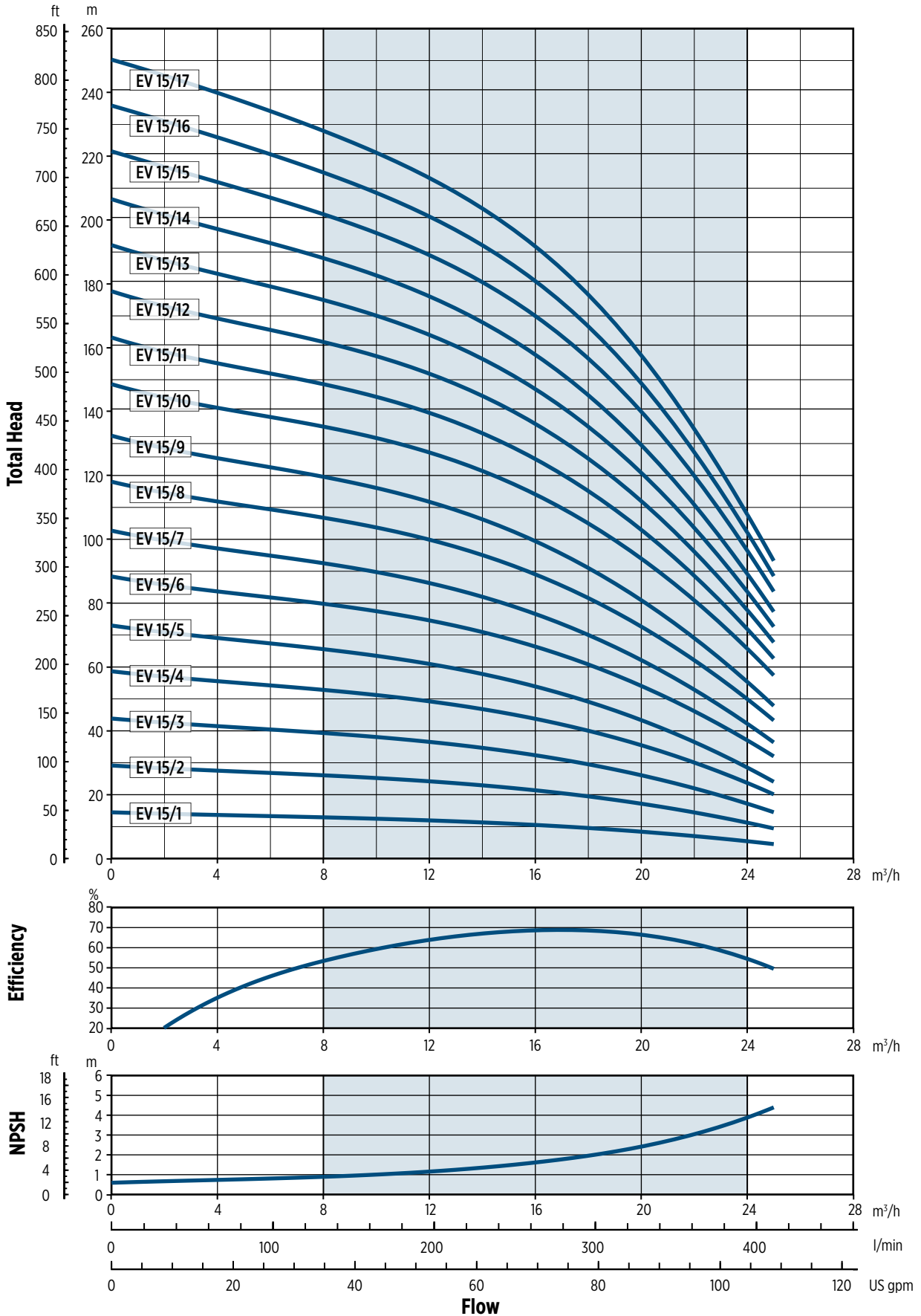

002018EN 02/2018

The hydraulic characteristics are guaranteed, according to ISO Standard 9906:2012, grade 3B



EV 15 - PERFORMANCE CURVES AT 50 Hz

MEI ≥ 0,70

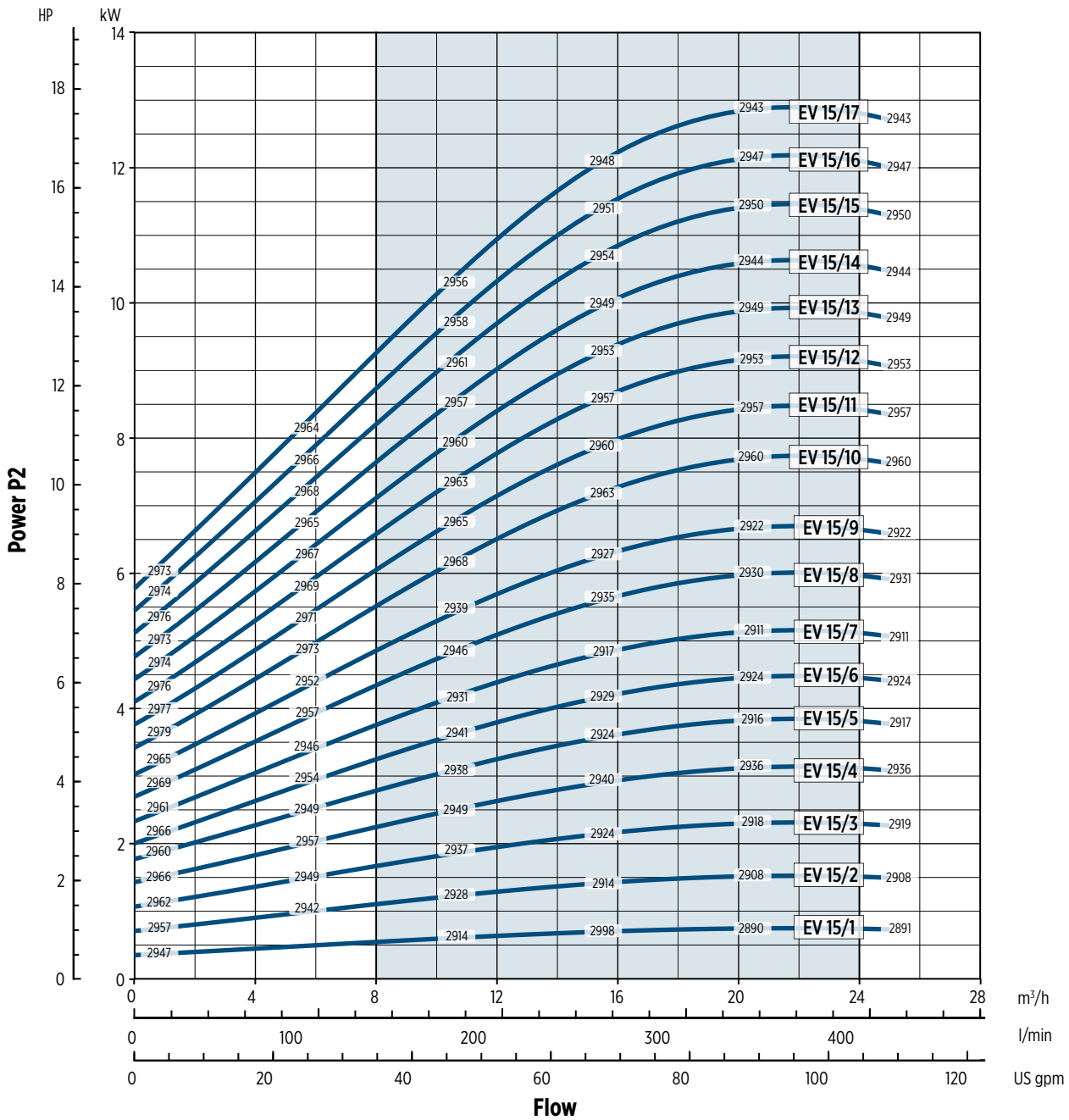

002018EN 02/2018

Performance curves of Q, H and P depend on the rpm number according to the following formula:

$$Q_2 = Q_1 \cdot \left(\frac{n_2}{n_1}\right), \quad H_2 = H_1 \cdot \left(\frac{n_2}{n_1}\right)^2, \quad P_2 = P_1 \cdot \left(\frac{n_2}{n_1}\right)^3, \quad \eta \text{ remains approximately the same.}$$

The rpm number related to the performance curves (Q-H-P) is indicated in the power chart.

Performance curves (Q-H-P) will change according to the formulas above.

Q=Capacity, H=Head, P=Power, h=Efficiency



EV 20 - 50 Hz

TECHNICAL DATA

Pump Model	MOTOR		Dimensions [mm]										Weight [kg]				
			L1		L2		L3	L4	L5	M		D1		D2	L1+L2	Pump	Motor
	[kW]	Dim	F	1-PHASE	3-PHASE	T	V	C	1-PHASE	3-PHASE	1-PHASE	3-PHASE					
EV 20/1	1.1	80	401	232	232	401	401	401	150	129	160	160	170	633	19.5	11.1	30.6
EV 20/2	2.2	90	411	267	267	411	411	411	160	138	180	180	170	678	21	16	37
EV 20/3	3	100	469	-	306	469	469	469	-	145	-	196	170	775	23	22.8	45.8
EV 20/4	4	112	517	-	306	517	517	517	-	145	-	196	170	823	24.5	26.5	51
EV 20/5	5.5	132	752	-	328	752	752	752	-	160	-	225	300	1080	46.5	33.6	80.1
EV 20/6	7.5	132	800	-	350	800	800	800	-	160	-	225	300	1150	48	36	84
EV 20/7	7.5	132	848	-	350	848	848	848	-	160	-	225	300	1198	49	36	85
EV 20/8	11	160	916	-	425	916	916	916	-	194	-	248	350	1341	53.5	59	112.5
EV 20/9	11	160	964	-	425	964	964	964	-	194	-	248	350	1389	55	59	114
EV 20/10	11	160	1012	-	425	1012	1012	1012	-	194	-	248	350	1437	56	59	115
EV 20/11	15	160	1060	-	476	-	1060	1060	-	194	-	248	350	1536	57.5	68	125.5
EV 20/12	15	160	1108	-	476	-	1108	1108	-	194	-	248	350	1584	59	68	127
EV 20/13	15	160	1156	-	476	-	1156	1156	-	194	-	248	350	1632	60.5	68	128.5
EV 20/14	15	160	1204	-	476	-	1204	1204	-	194	-	248	350	1680	62	68	130
EV 20/15	18.5	160	1252	-	542	-	1252	1252	-	238	-	317	350	1794	63	104	167
EV 20/16	18.5	160	1300	-	542	-	1300	1300	-	238	-	317	350	1842	64.5	104	168.5
EV 20/17	18.5	160	1348	-	542	-	1348	1348	-	238	-	317	350	1890	66	104	170

DIMENSIONAL DRAWINGS

F Version

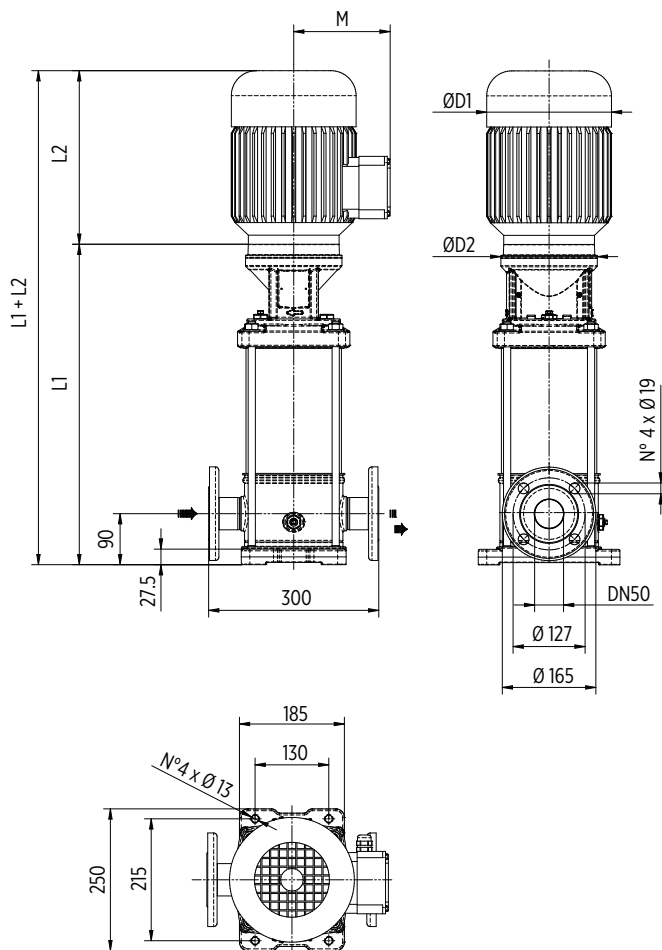

Round flanges on body type PN25: the pump is supplied without counterflanges (Optional accessories, including bolts and joints)

T Version

Available from EV20/1 to EV20/10

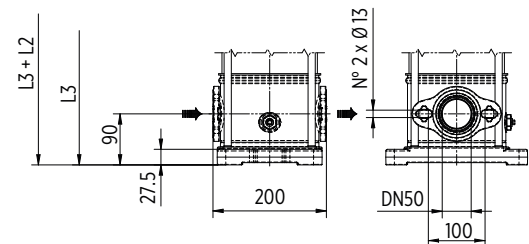

Oval flanges on body type PN16: the pump is supplied without threaded oval counter flanges (Optional accessories, including bolts and joints)

V Version

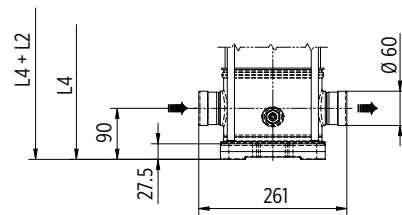

Connections with rapid fittings type "Victaulic": the pump is supplied without the collars (Optional accessories)

C Version

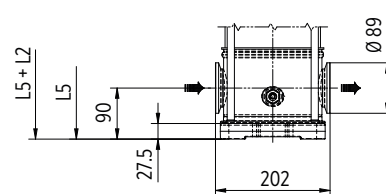

Connections with round fittings type Clamp-FlexiClamp: the pump is supplied without collars (Optional accessories)

00150102EN 02/2018

EV 20 - PERFORMANCE CURVES AT 50 Hz

MEI ≥ 0,70

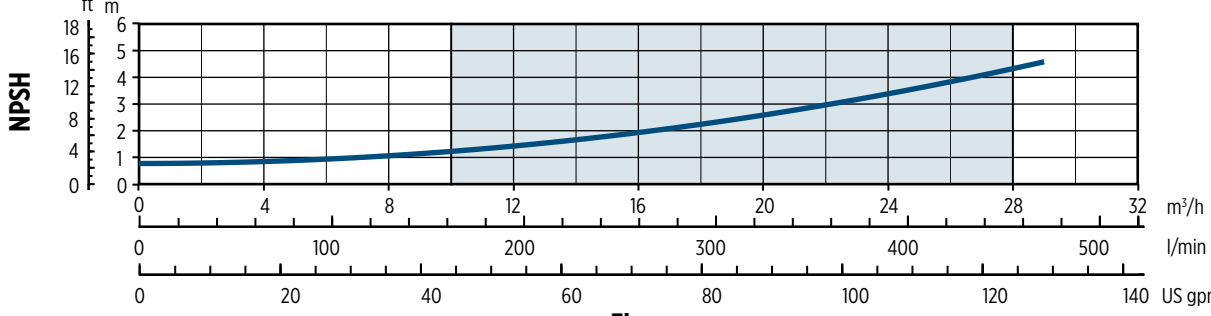
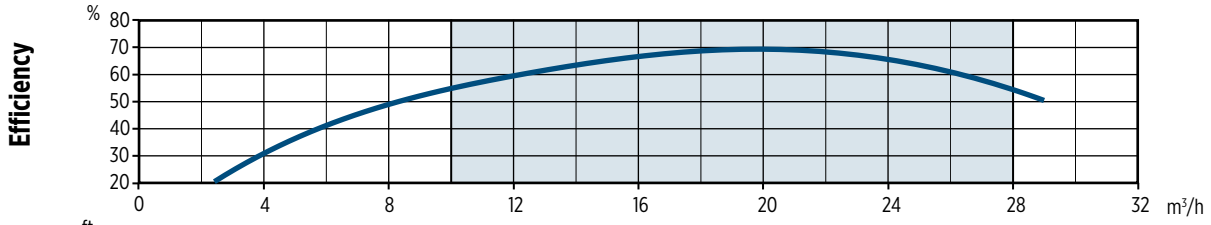
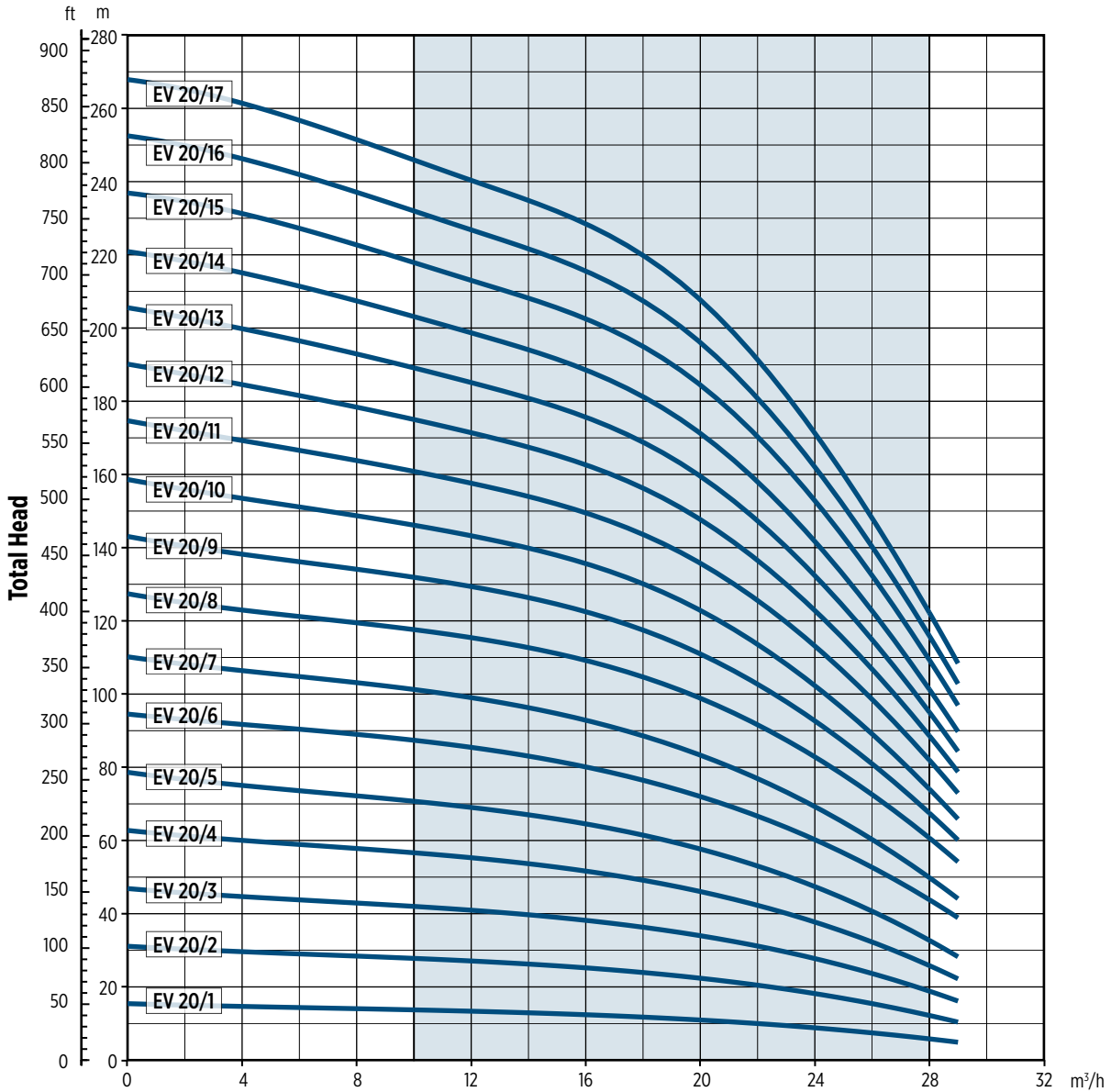

0012019EN 02/2018

The hydraulic characteristics are guaranteed, according to ISO Standard 9906:2012, grade 3B

EV 20 - PERFORMANCE CURVES AT 50 Hz

MEI ≥ 0,70

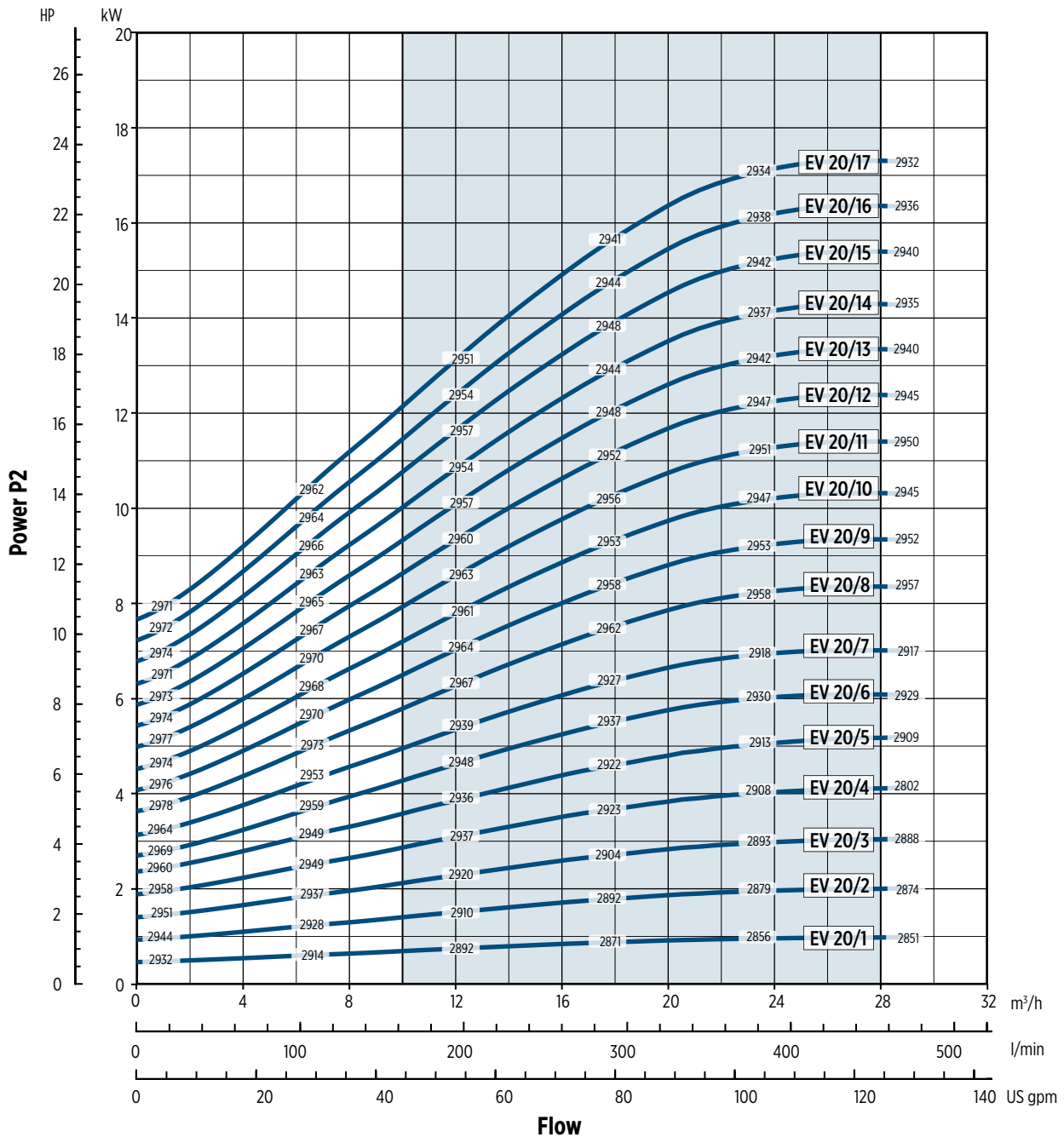

0012018EN 02/2018

Performance curves of Q, H and P depend on the rpm number according to the following formula:

$$Q_2 = Q_1 \cdot \left(\frac{n_2}{n_1}\right), \quad H_2 = H_1 \cdot \left(\frac{n_2}{n_1}\right)^2, \quad P_2 = P_1 \cdot \left(\frac{n_2}{n_1}\right)^3, \quad \eta \text{ remains approximately the same.}$$

The rpm number related to the performance curves (Q-H-P) is indicated in the power chart.

Performance curves (Q-H-P) will change according to the formulas above.

Q=Capacity, H=Head, P=Power, η=Efficiency



EV 30 - 50 Hz

TECHNICAL DATA

Pump Model	MOTOR		Dimensions [mm]						Weight [kg]		
	[kW]	Dim	L1	L2	M	D1	D2	L1+L2	Pump	Motor	Electric Pump
EV 30/1	2.2	90	445	267	138	180	170	712	48.5	16	64.5
EV 30/2-2a	4	112	537	306	145	196	170	843	53	26.5	79.5
EV 30/2-1a	4	112	537	306	145	196	170	843	53	26.5	79.5
EV 30/2	5.5	132	724	328	160	225	300	1052	73.5	33.6	107.1
EV 30/3-2a	5.5	132	806	328	160	225	300	1134	77.5	33.6	111.1
EV 30/3-1a	7.5	132	806	350	160	225	300	1156	77.5	36	113.5
EV 30/3	7.5	132	806	350	160	225	300	1156	77.5	36	113.5
EV 30/4-2a	7.5	132	888	350	160	225	300	1238	81.5	36	117.5
EV 30/4-1a	11	160	908	425	194	248	350	1333	84	59	143
EV 30/4	11	160	908	425	194	248	350	1333	84	59	143
EV 30/5-2a	11	160	991	425	194	248	350	1416	88	59	147
EV 30/5-1a	11	160	991	425	194	248	350	1416	88	59	147
EV 30/5	15	160	991	476	194	248	350	1467	88	68	156
EV 30/6-2a	15	160	1073	476	194	248	350	1549	92	68	160
EV 30/6-1a	15	160	1073	476	194	248	350	1549	92	68	160
EV 30/6	15	160	1073	476	194	248	350	1549	92	68	160
EV 30/7-2a	15	160	1155	476	194	248	350	1631	96	68	164
EV 30/7-1a	15	160	1155	476	194	248	350	1631	96	68	164
EV 30/7	18.5	160	1155	542	238	317	350	1697	96	104	200
EV 30/8-2a	18.5	160	1237	542	238	317	350	1779	100	104	204
EV 30/8-1a	18.5	160	1237	542	238	317	350	1779	100	104	204
EV 30/8	18.5	160	1237	542	238	317	350	1779	100	104	204
EV 30/9-2a	22	180	1319	542	238	317	350	1861	104.5	106	210.5
EV 30/9-1a	22	180	1319	542	238	317	350	1861	104.5	106	210.5
EV 30/9	22	180	1319	542	238	317	350	1861	104.5	106	210.5
EV 30/10-2a	22	180	1401	542	238	317	350	1943	108.5	106	214.5
EV 30/10-1a	22	180	1401	542	238	317	350	1943	108.5	106	214.5
EV 30/10	30	200	1406	658	297	399	400	2064	112	276	388
EV 30/11-2a	30	200	1488	658	297	399	400	2146	116	276	392
EV 30/11-1a	30	200	1488	658	297	399	400	2146	116	276	392
EV 30/11	30	200	1488	658	297	399	400	2146	116	276	392
EV 30/12-2a	30	200	1570	658	297	399	400	2228	119.5	276	395.5
EV 30/12-1a	30	200	1570	658	297	399	400	2228	119.5	276	395.5
EV 30/12	30	200	1570	658	297	399	400	2228	119.5	276	395.5
EV 30/13-2a	30	200	1652	658	297	399	400	2310	123.5	276	399.5
EV 30/13-1a	30	200	1652	658	297	399	400	2310	123.5	276	399.5
EV 30/13	30	200	1652	658	297	399	400	2310	123.5	276	399.5

DIMENSIONAL DRAWINGS

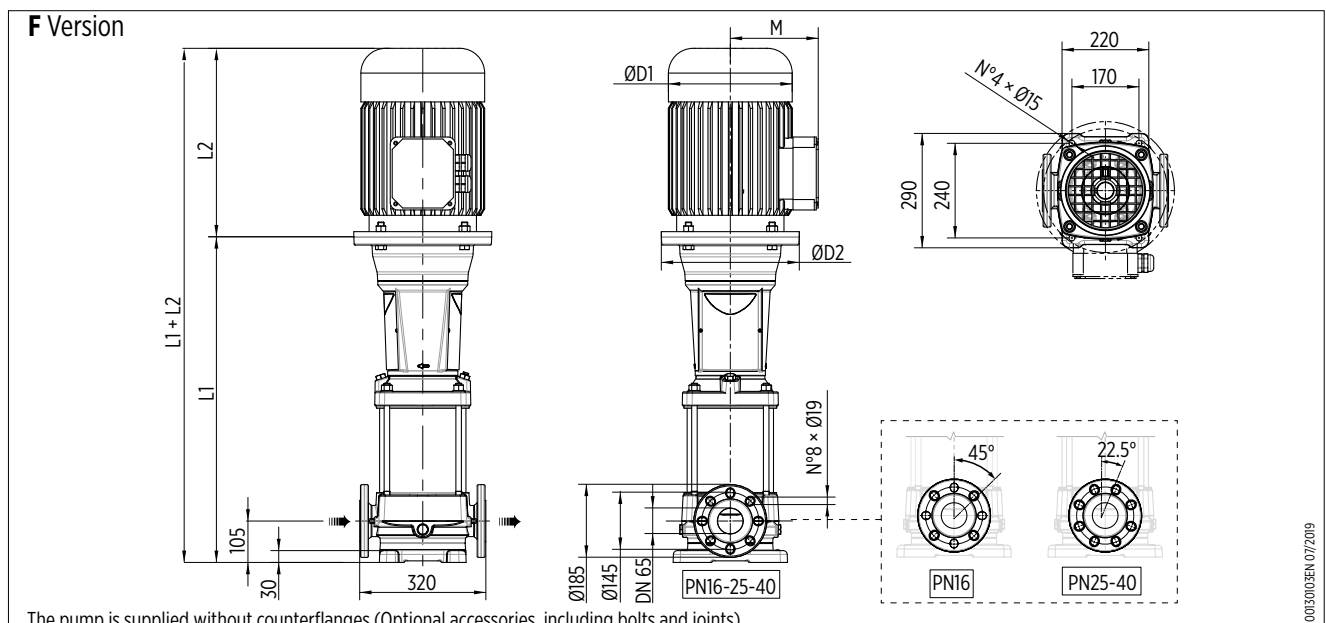

EV 30 - PERFORMANCE CURVES AT 50 Hz

MEI ≥ 0,70

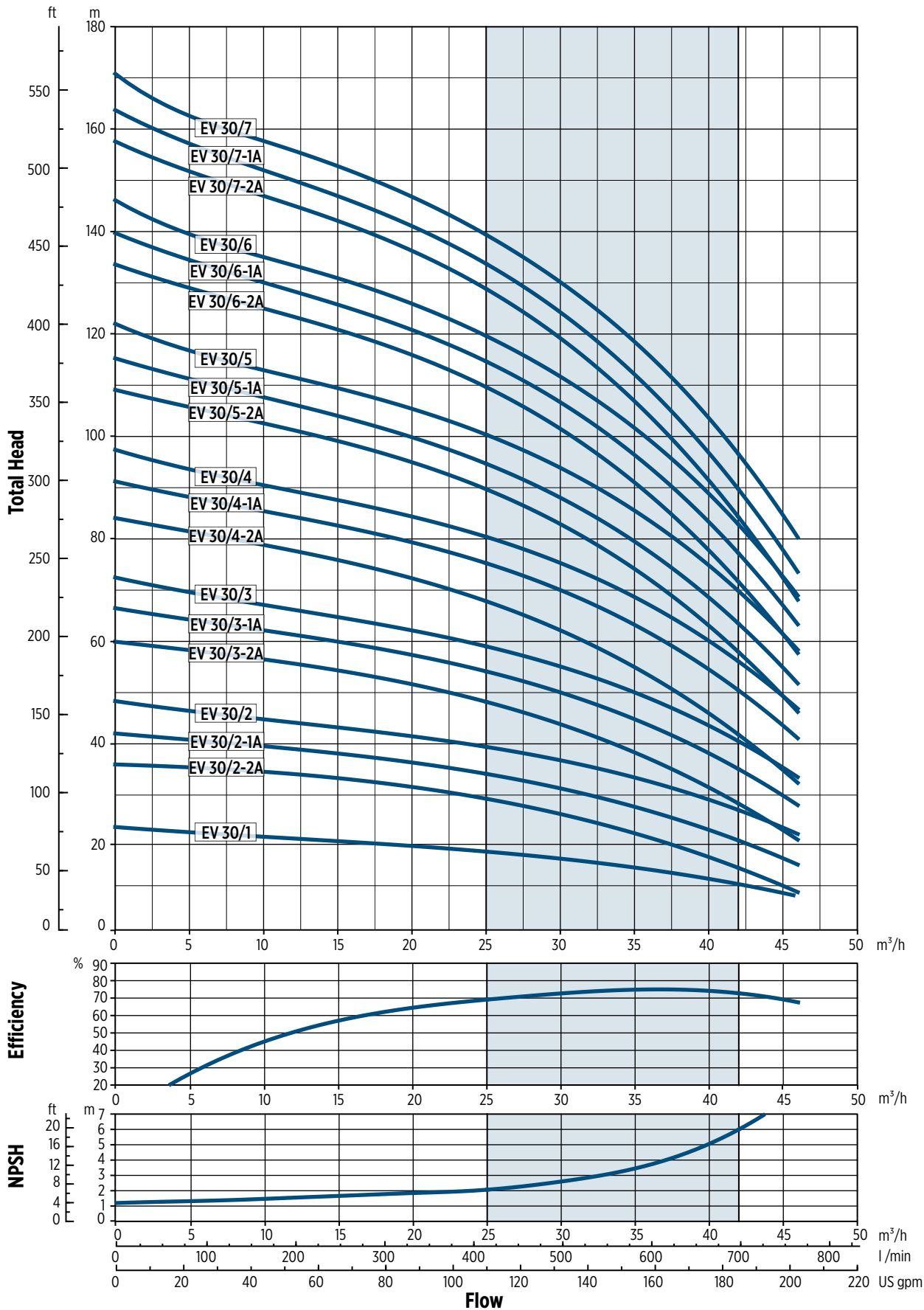

0012020AEN 02/2018

The hydraulic characteristics are guaranteed, according to ISO Standard 9906:2012, grade 3B



EV 30 - PERFORMANCE CURVES AT 50 Hz

MEI ≥ 0,70

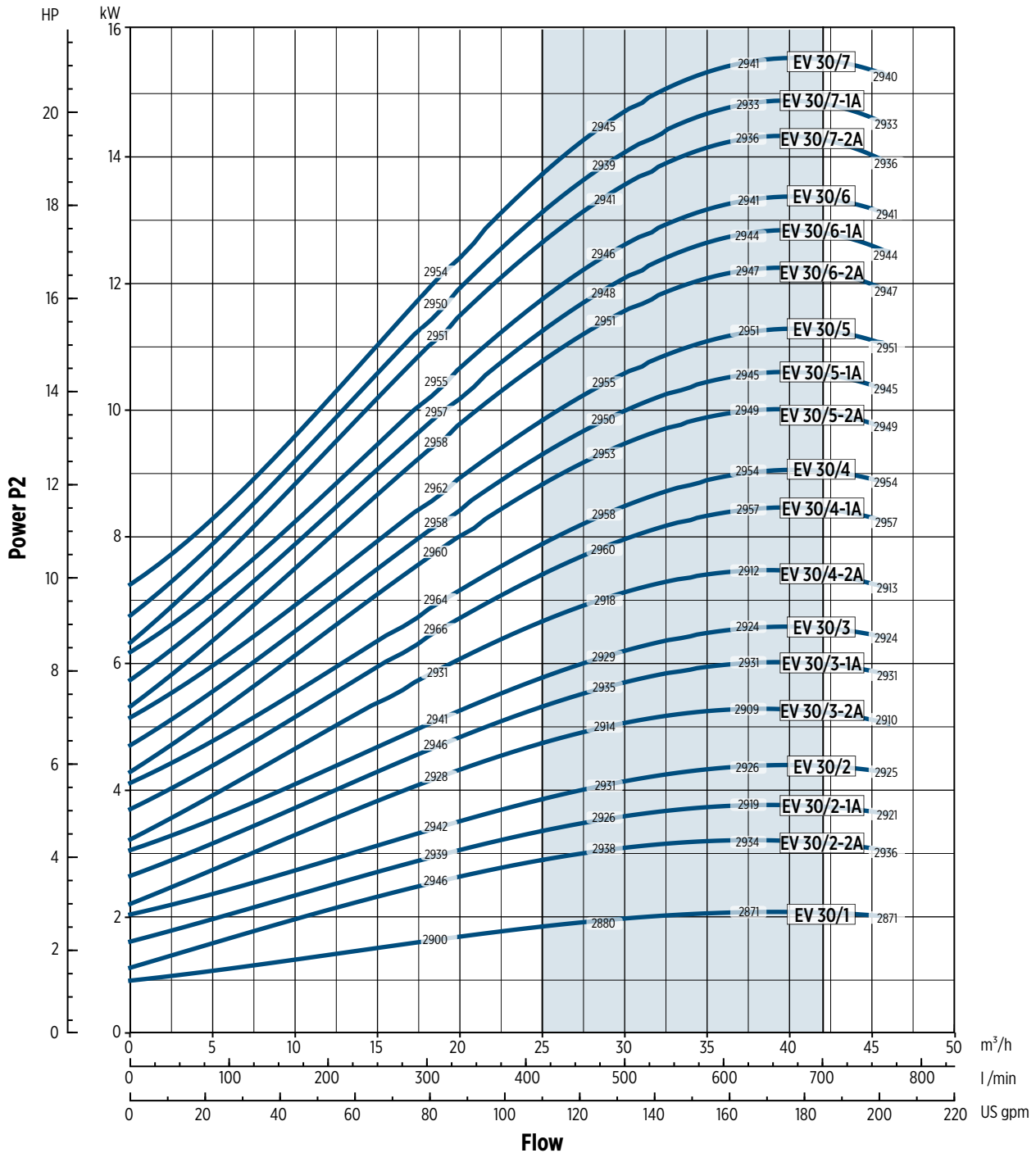

002020AEN 02/2018

Performance curves of Q, H and P depend on the rpm number according to the following formula:

$$Q_2 = Q_1 \cdot \left(\frac{n_2}{n_1}\right), \quad H_2 = H_1 \cdot \left(\frac{n_2}{n_1}\right)^2, \quad P_2 = P_1 \cdot \left(\frac{n_2}{n_1}\right)^3, \quad \eta \text{ remains approximately the same.}$$

The rpm number related to the performance curves (Q-H-P) is indicated in the power chart.

Performance curves (Q-H-P) will change according to the formulas above.

Q=Capacity, H=Head, P=Power, h=Efficiency

EV 30 - PERFORMANCE CURVES AT 50 Hz

MEI ≥ 0,70

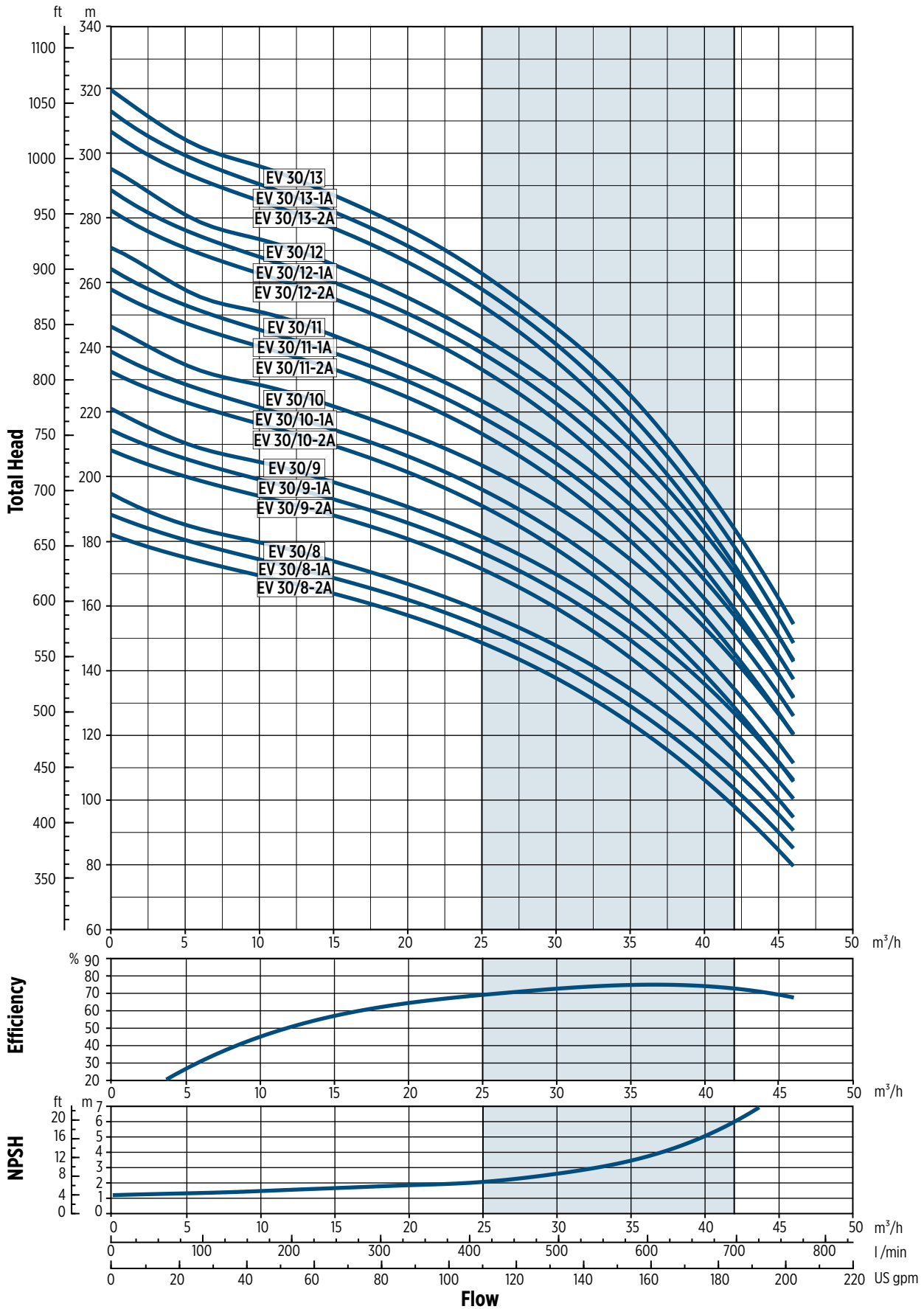

00102028BEN 02/2018

The hydraulic characteristics are guaranteed, according to ISO Standard 9906:2012, grade 3B

EV 30 - PERFORMANCE CURVES AT 50 Hz

MEI ≥ 0,70

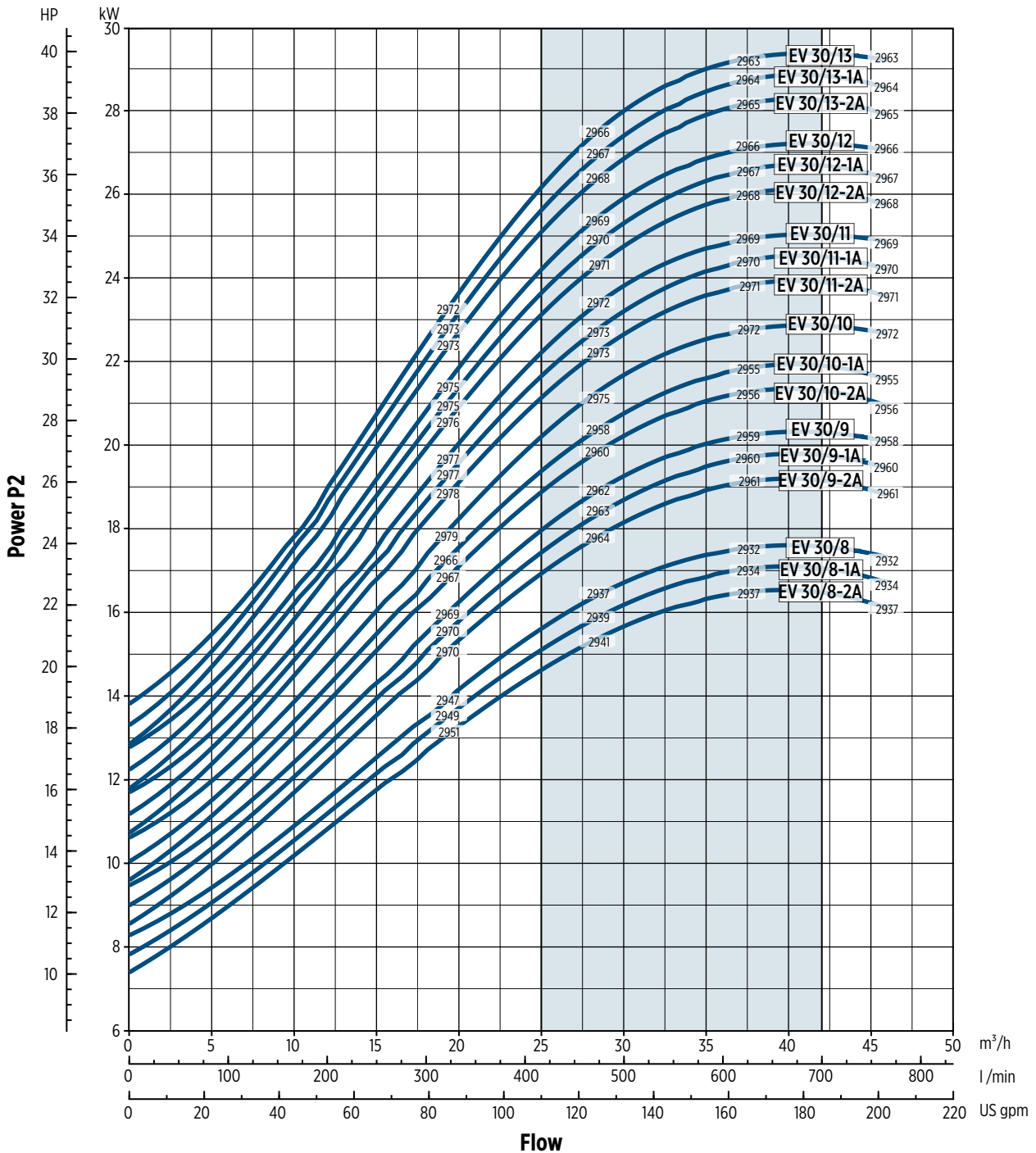

0012018EN 02/2018

Performance curves of Q, H and P depend on the rpm number according to the following formula:

$$Q_2 = Q_1 \cdot \left(\frac{n_2}{n_1}\right), \quad H_2 = H_1 \cdot \left(\frac{n_2}{n_1}\right)^2, \quad P_2 = P_1 \cdot \left(\frac{n_2}{n_1}\right)^3, \quad \eta \text{ remains approximately the same.}$$

The rpm number related to the performance curves (Q-H-P) is indicated in the power chart.

Performance curves (Q-H-P) will change according to the formulas above.

Q=Capacity, H=Head, P=Power, h=Efficiency

EV 45 - 50 Hz

TECHNICAL DATA

Pump Model	MOTOR		Dimensions [mm]						Weight [kg]		
	[kW]	Dim	L1	L2	M	D1	D2	L1+L2	Pump	Motor	Electric Pump
EV 45/1-1a	3	100	490	306	145	196	170	796	55	22.8	77.8
EV 45/1	4	112	490	306	145	196	170	796	55	26.5	81.5
EV 45/2-2a	5.5	132	759	328	160	225	300	1087	79	33.6	112.6
EV 45/2	7.5	132	759	350	160	225	300	1109	79	36	115
EV 45/3-2a	11	160	861	425	194	248	350	1286	86	59	145
EV 45/3	11	160	861	425	194	248	350	1286	86	59	145
EV 45/4-2a	15	160	943	476	194	248	350	1419	90	68	158
EV 45/4	15	160	943	476	194	248	350	1419	90	68	158
EV 45/5-2a	18.5	160	1026	542	238	317	350	1568	94	104	198
EV 45/5	18.5	160	1026	542	238	317	350	1568	94	104	198
EV 45/6-2a	22	180	1108	542	238	317	350	1650	98.5	106	204.5
EV 45/6	22	180	1108	542	238	317	350	1650	98.5	106	204.5
EV 45/7-2a	30	200	1195	658	297	399	400	1853	105.5	276	381.5
EV 45/7	30	200	1195	658	297	399	400	1853	105.5	276	381.5
EV 45/8-2a	30	200	1277	658	297	399	400	1935	109.5	276	385.5
EV 45/8	30	200	1277	658	297	399	400	1935	109.5	276	385.5
EV 45/9-2a	37	200	1359	658	297	399	400	2017	113.5	283	396.5
EV 45/9	37	200	1359	658	297	399	400	2017	113.5	283	396.5
EV 45/10-2a	37	200	1441	658	297	399	400	2099	117.5	283	400.5
EV 45/10	37	200	1441	658	297	399	400	2099	117.5	283	400.5
EV 45/11-2a	45	225	1523	699	328	465	450	2222	124.5	370	494.5
EV 45/11	45	225	1523	699	328	465	450	2222	124.5	370	494.5
EV 45/12-2a	45	225	1605	699	328	465	450	2304	128.5	370	498.5
EV 45/12	45	225	1605	699	328	465	450	2304	128.5	370	498.5
EV 45/13-2a	45	225	1687	699	328	465	450	2386	132.5	370	502.5

DIMENSIONAL DRAWINGS

F Version

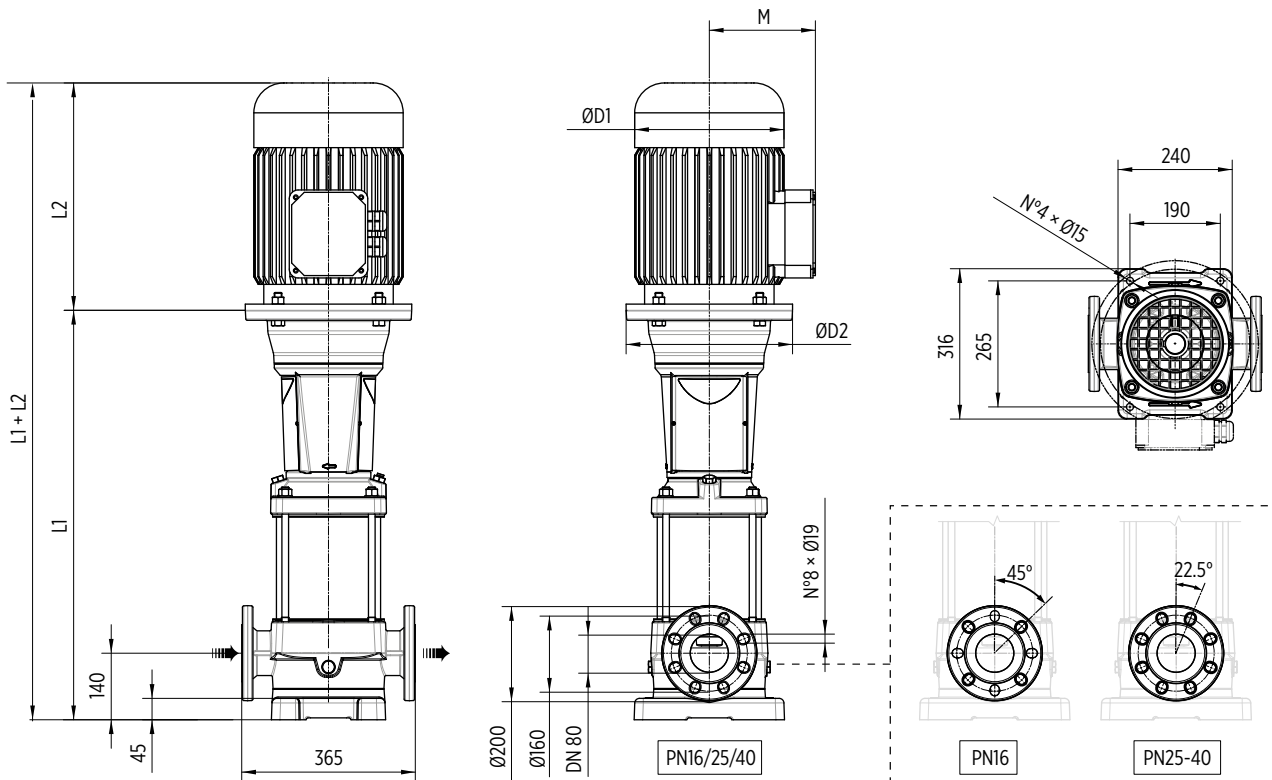

The pump is supplied without counterflanges (Optional accessories, including bolts and joints)

EV 45 - PERFORMANCE CURVES AT 50 Hz

MEI ≥ 0,70

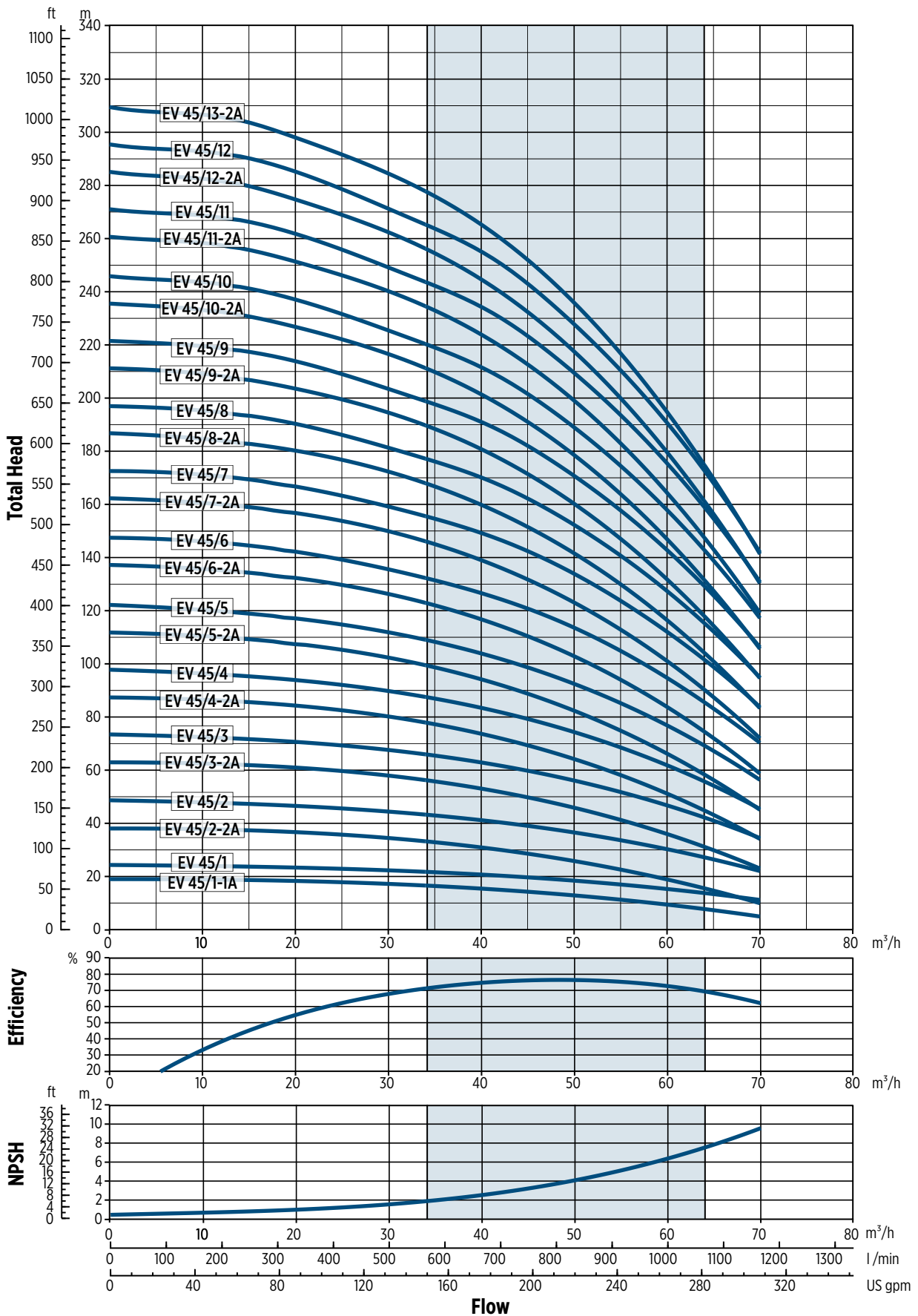

002021ZEN 02/2018

The hydraulic characteristics are guaranteed, according to ISO Standard 9906:2012, grade 3B

EV 45 - PERFORMANCE CURVES AT 50 Hz

MEI ≥ 0,70

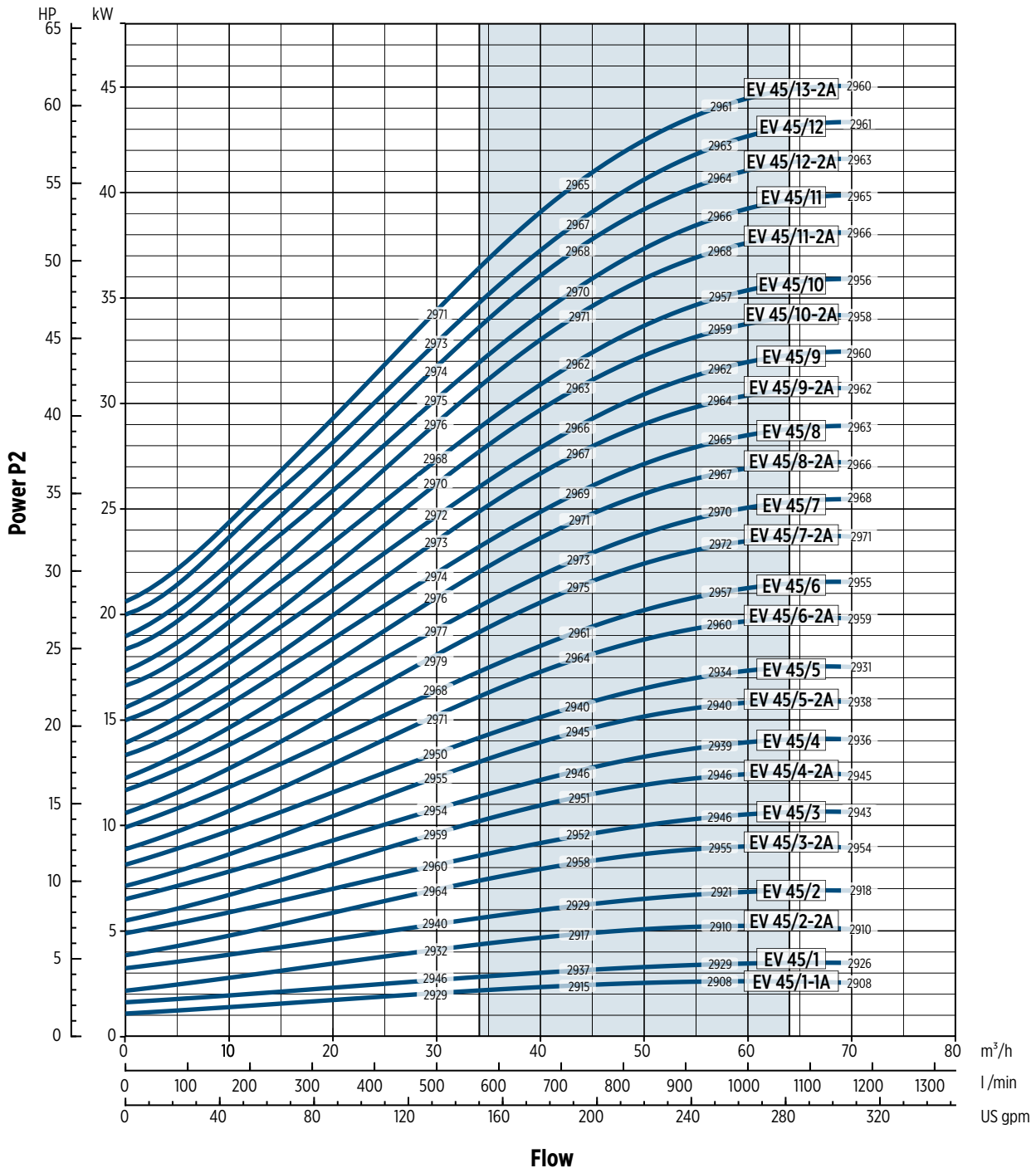

001201ZEN 02/2018

Performance curves of Q, H and P depend on the rpm number according to the following formula:

$$Q_2 = Q_1 \cdot \left(\frac{n_2}{n_1}\right), \quad H_2 = H_1 \cdot \left(\frac{n_2}{n_1}\right)^2, \quad P_2 = P_1 \cdot \left(\frac{n_2}{n_1}\right)^3, \quad \eta \text{ remains approximately the same.}$$

The rpm number related to the performance curves (Q-H-P) is indicated in the power chart.

Performance curves (Q-H-P) will change according to the formulas above.

Q=Capacity, H=Head, P=Power, h=Efficiency



EV 65 - 50 Hz

TECHNICAL DATA

Pump Model	MOTOR		Dimensions [mm]						Weight [kg]		
	[kW]	Dim	L1	L2	M	D1	D2	L1+L2	Pump	Motor	Electric Pump
EV 65/1-1a	4	112	550	306	145	196	170	856	61	26.5	87.5
EV 65/1	5.5	132	737	328	160	225	300	1065	81	33.6	114.6
EV 65/2-2a	7.5	132	829	350	160	225	300	1179	85.5	36	121.5
EV 65/2-1a	11	160	849	425	194	248	350	1274	88.5	59	147.5
EV 65/2	11	160	849	425	194	248	350	1274	88.5	59	147.5
EV 65/3-2a	15	160	941	476	194	248	350	1417	93	68	161
EV 65/3-1a	15	160	941	476	194	248	350	1417	93	68	161
EV 65/3	18.5	160	941	542	238	317	350	1483	93	104	197
EV 65/4-2a	18.5	160	1033	542	238	317	350	1575	97.5	104	201.5
EV 65/4-1a	22	180	1033	542	238	317	350	1575	98	106	204
EV 65/4	22	180	1033	542	238	317	350	1575	98	106	204
EV 65/5-2a	30	200	1131	658	297	399	400	1789	105.5	276	381.5
EV 65/5-1a	30	200	1131	658	297	399	400	1789	105.5	276	381.5
EV 65/5	30	200	1131	658	297	399	400	1789	105.5	276	381.5
EV 65/6-2a	30	200	1223	658	297	399	400	1881	110	276	386
EV 65/6-1a	37	200	1223	658	297	399	400	1881	110	283	393
EV 65/6	37	200	1223	658	297	399	400	1881	110	283	393
EV 65/7-2a	37	200	1315	658	297	399	400	1973	114.5	283	397.5
EV 65/7-1a	37	200	1315	658	297	399	400	1973	114.5	283	397.5
EV 65/7	45	225	1315	699	328	465	450	2014	117.5	370	487.5
EV 65/8-2a	45	225	1407	699	328	465	450	2106	122	370	492
EV 65/8-1a	45	225	1407	699	328	465	450	2106	122	370	492
EV 65/8	45	225	1407	699	328	465	450	2106	122	370	492

DIMENSIONAL DRAWINGS

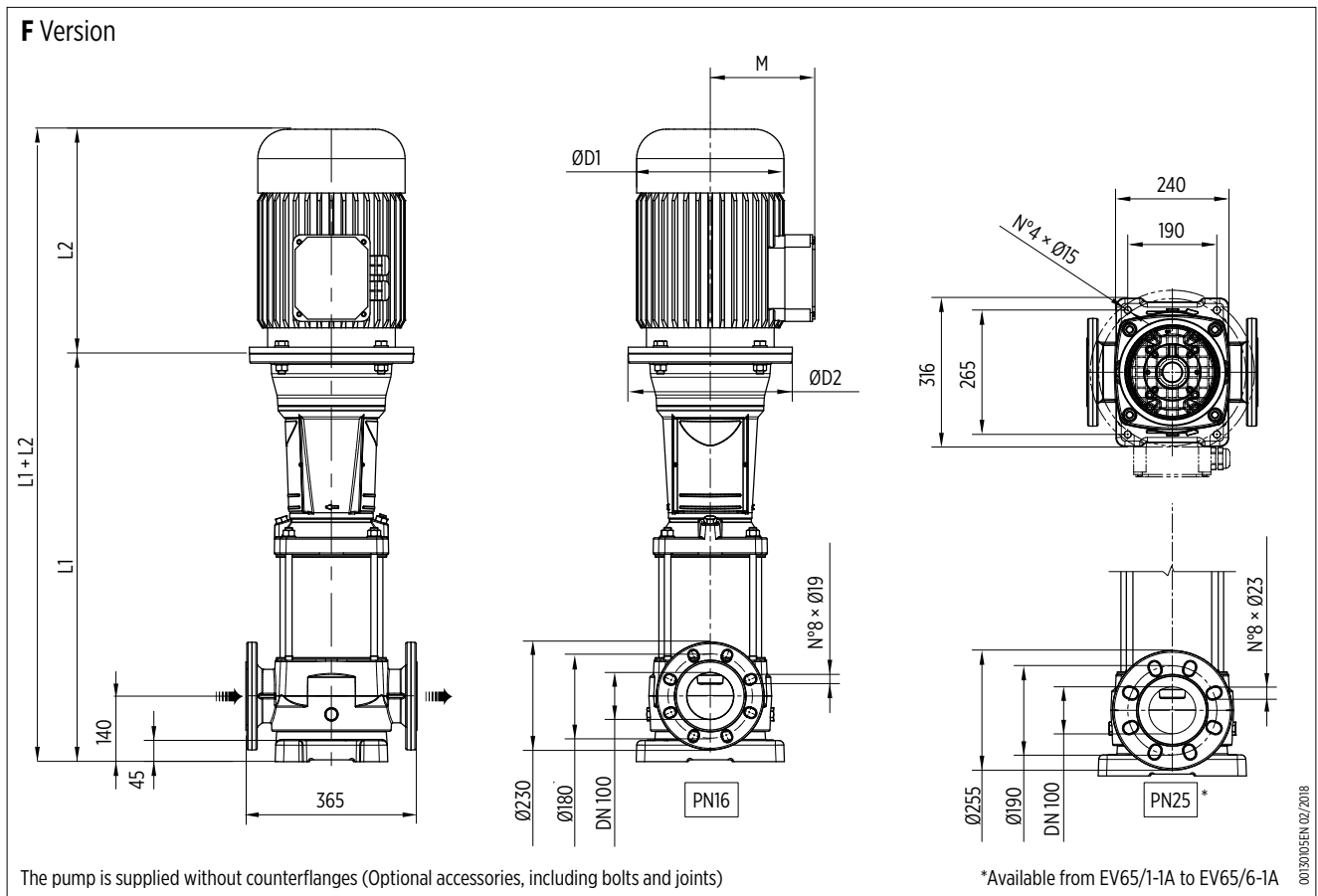

EV 65 - PERFORMANCE CURVES AT 50 Hz

MEI ≥ 0,70

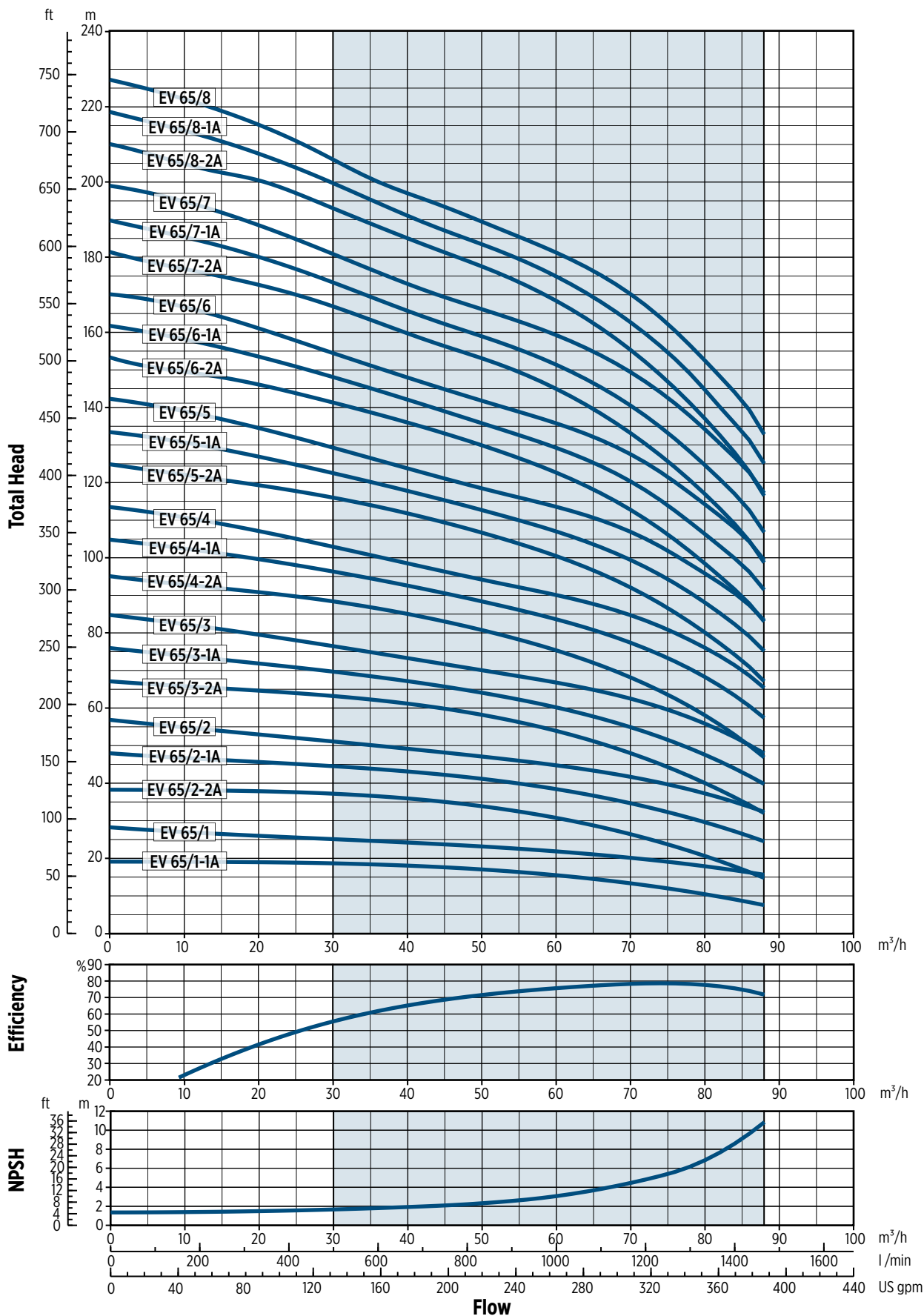

002020ZEN 02/2018

The hydraulic characteristics are guaranteed, according to ISO Standard 9906:2012, grade 3B



EV 65 - PERFORMANCE CURVES AT 50 Hz

MEI ≥ 0,70

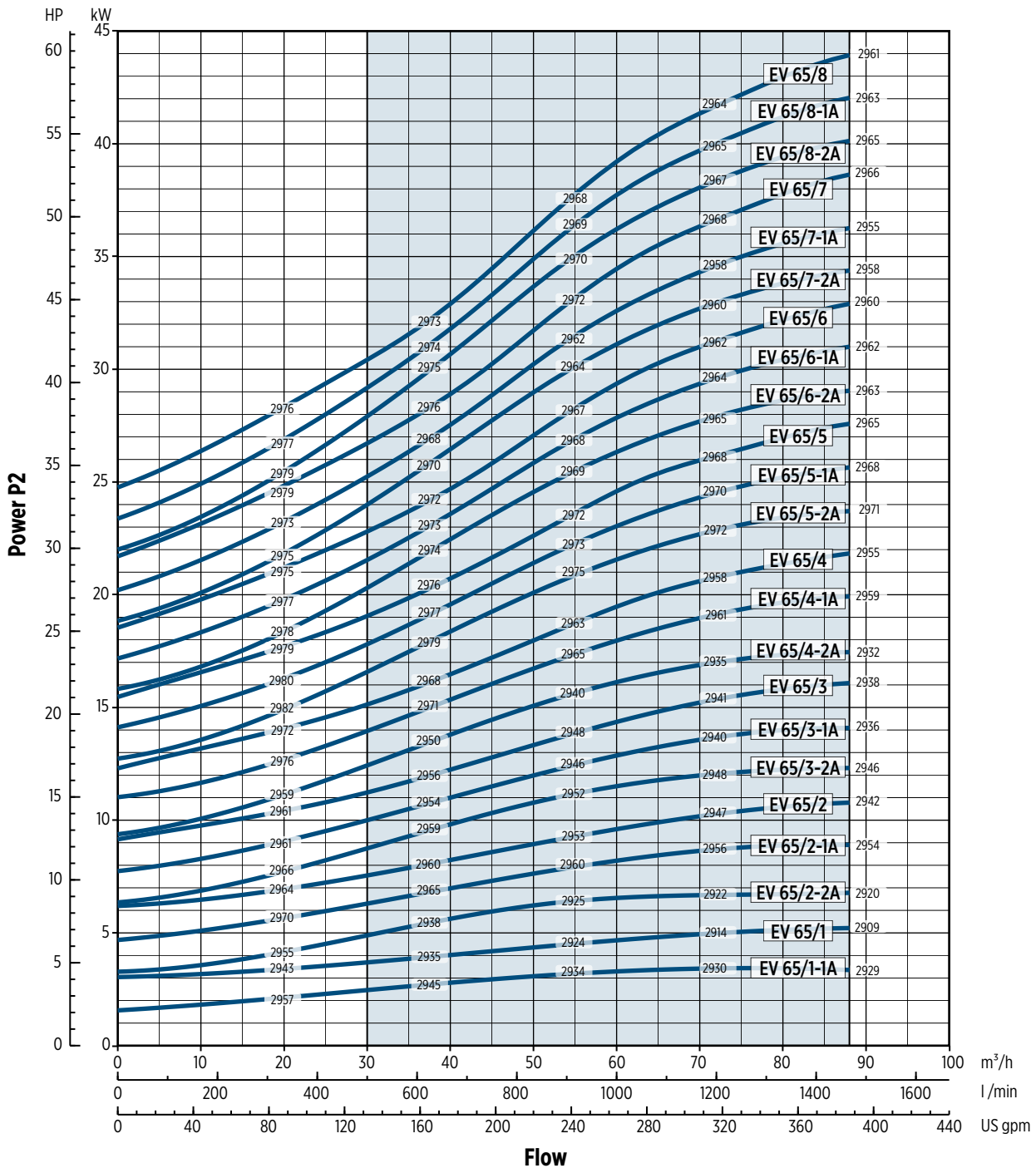

001201ZEN 02/2018

Performance curves of Q, H and P depend on the rpm number according to the following formula:

$$Q_2 = Q_1 \cdot \left(\frac{n_2}{n_1}\right), \quad H_2 = H_1 \cdot \left(\frac{n_2}{n_1}\right)^2, \quad P_2 = P_1 \cdot \left(\frac{n_2}{n_1}\right)^3, \quad \eta \text{ remains approximately the same.}$$

The rpm number related to the performance curves (Q-H-P) is indicated in the power chart.

Performance curves (Q-H-P) will change according to the formulas above.

Q=Capacity, H=Head, P=Power, h=Efficiency

EV 95 - 50 Hz

TECHNICAL DATA

Pump Model	MOTOR		Dimensions [mm]						Weight [kg]		
	[kW]	Dim	L1	L2	M	D1	D2	L1+L2	Pump	Motor	Electric Pump
EV 95/1-1a	5.5	132	737	328	160	225	300	1065	82.5	33.6	116.1
EV 95/1	7.5	132	737	350	160	225	300	1087	82.5	36	118.5
EV 95/2-2a	11	160	849	425	194	248	350	1274	89	59	148
EV 95/2	15	160	849	476	194	248	350	1325	89	68	157
EV 95/3-2a	18.5	160	941	542	238	317	350	1483	93	104	197
EV 95/3	22	180	941	542	238	317	350	1483	93	106	199
EV 95/4-2a	30	200	1038	658	297	399	400	1696	100	276	376
EV 95/4	30	200	1038	658	297	399	400	1696	100	276	376
EV 95/5-2a	37	200	1131	658	297	399	400	1789	104	283	387
EV 95/5	37	200	1131	658	297	399	400	1789	104	283	387
EV 95/6-2a	45	225	1223	699	328	465	450	1922	110.5	370	480.5
EV 95/6	45	225	1223	699	328	465	450	1922	110.5	370	480.5

DIMENSIONAL DRAWINGS

F Version

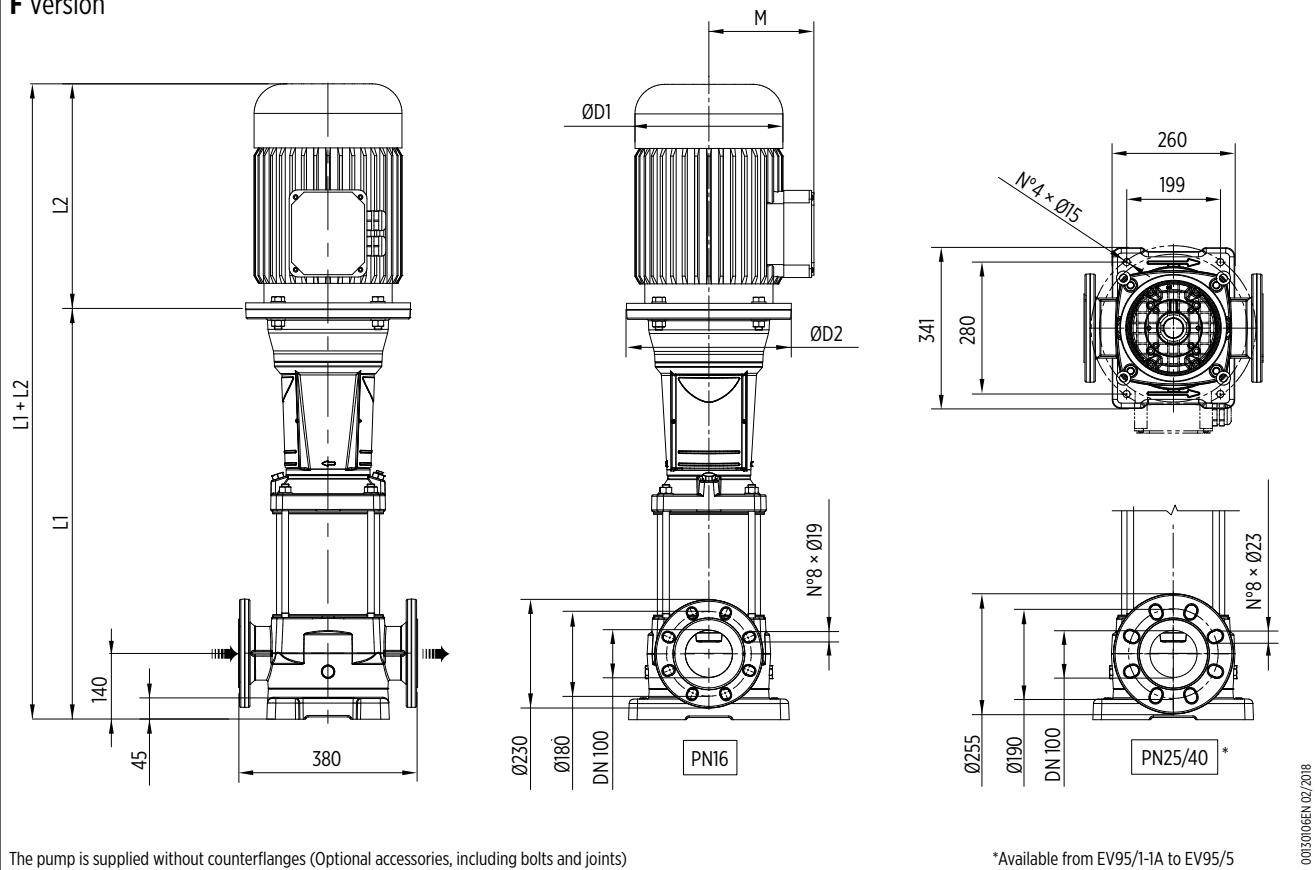

EV 95 - PERFORMANCE CURVES AT 50 Hz

MEI ≥ 0,70

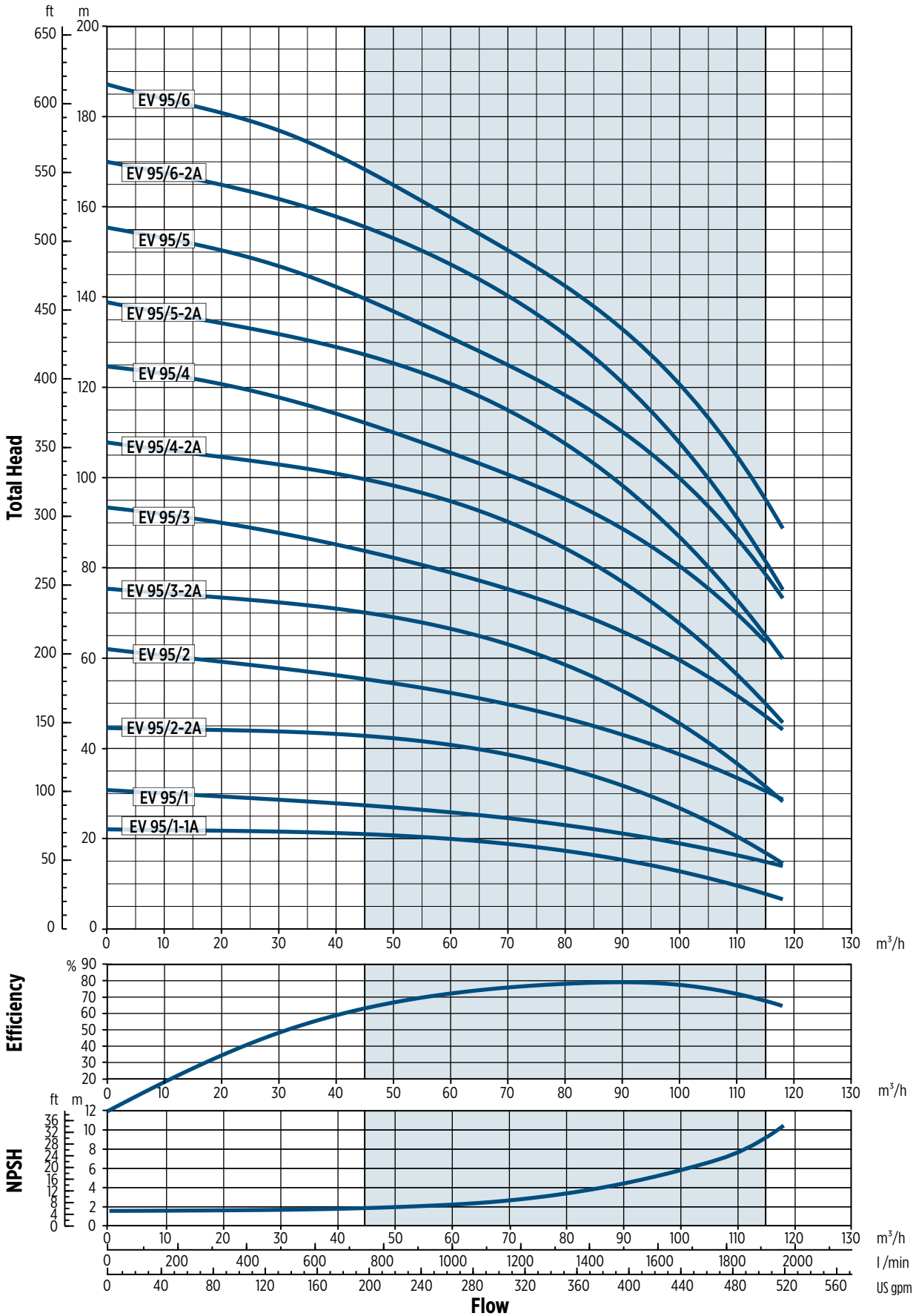

0102102XEN 02/2018

The hydraulic characteristics are guaranteed, according to ISO Standard 9906:2012, grade 3B

EV 95 - PERFORMANCE CURVES AT 50 Hz

MEI ≥ 0,70

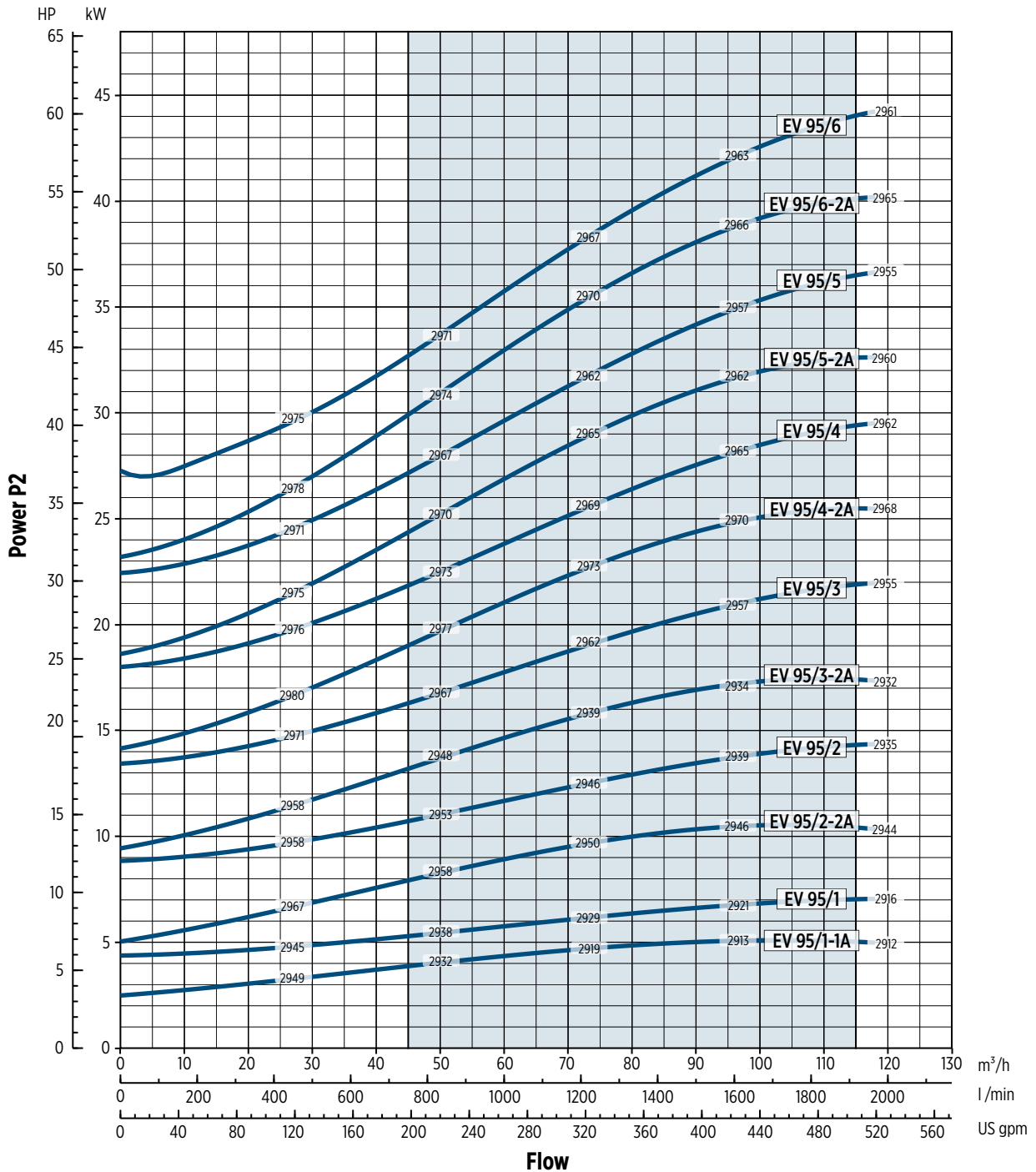

Performance curves of Q, H and P depend on the rpm number according to the following formula:

$$Q_2 = Q_1 \cdot \left(\frac{n_2}{n_1}\right), \quad H_2 = H_1 \cdot \left(\frac{n_2}{n_1}\right)^2, \quad P_2 = P_1 \cdot \left(\frac{n_2}{n_1}\right)^3, \quad \eta \text{ remains approximately the same.}$$

The rpm number related to the performance curves (Q-H-P) is indicated in the power chart.

Performance curves (Q-H-P) will change according to the formulas above.

Q=Capacity, H=Head, P=Power, h=Efficiency

DIMENSIONS OF COUNTERFLANGES

OVAL COUNTERFLANGES

DN	DIMENSIONS [mm]					HOLES		PN
	D	d1	k	L	b	d2	N°	
32	99	Rp 1" ¼ NPT 1" ¼	75	33	8	11	2	16
40	130	Rp 1" ½ NPT 1" ½	100	35	10	13		
50		Rp 2" NPT 2"		39				

Kit round counterflanges available on request; AISI 304 (EN 1.4301)

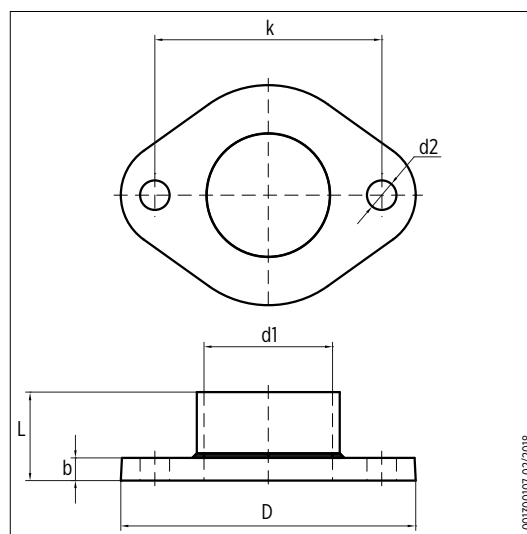

001300107 02/2018

ROUND THREADED COUNTERFLANGES ACCORDING TO EN 1092-1

DN	DIMENSIONS [mm]					HOLES		PN
	D	d1	k	L	b	d2	N°	
25	115	Rp 1" NPT 1"	85	43	16	14	4	25
32	140	Rp 1" ¼ NPT 1" ¼	100			18		
40	150	Rp 1" ½ NPT 1" ½	110			19		
50	165	Rp 2" NPT 2"	127	32	18	18	8	16
65	185	Rp 2" ½ NPT 2" ½	145					
80	200	Rp 3" NPT 3"	160					
100	220	Rp 4" NPT 4"	180	40				

Kit round counterflanges available on request:

DN 25-32-40-50: galvanized steel, AISI 304 (EN 1.4301), AISI 316L (EN 1.4404)

DN 65-80-100: galvanized steel, AISI 316 (EN 1.4401)

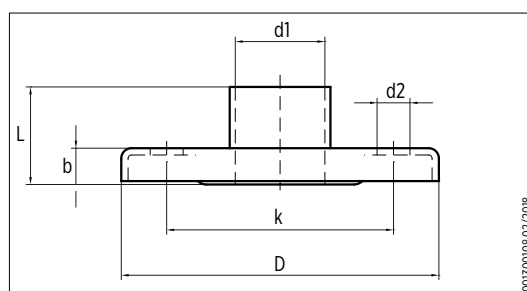

001300108 02/2018

WELDING ROUND COUNTERFLANGES ACCORDING TO EN 1092-1

DN	DIMENSIONS [mm]					HOLES		PN
	D	d1	k	L	b	d2	N°	
65	185	77,5	145	-	22	18	8	25/40
80	200	90,5	160		24			
100	235	116	190		26			

Kit round counterflanges available on request; AISI 316 (EN 1.4401)

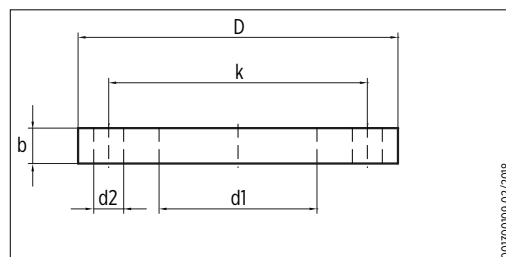

001300109 02/2018

CATALOG REVISION CHANGE NOTICE

Rev. No.	Changes	Page
02	Modification of dimensional drawings of EV 15	46 (REV.02)
	Modification of technical data of EV 20	50 (REV.02)
03	Modification of specifications of mechanical seal	14
	Modification of dimensions of EV 45	57
	Modification of dimensions of EV 95	65
04	Modification of product description	2
	Modification of "Mechanical seal specifications"	14
	Modification of table "Compatibility of fluids and materials"	15
05	Modification of table "Flange models"	3
	Union of Spare part lists and "Compatibility of fluids and materials"	10 ÷ 15
	Modification of table "Standard version - unbalanced" of Mechanical seal specification	19
	Modification of table "Compatibility of fluids and materials"	20
06	Modification of "Flange models" tables	3
	Modification of "Spare parts and material"	10 ÷ 15
	Modification of "Dimensional drawing" for EV 30-45	55, 61



Franklin Electric

Franklin Electric S.r.l.
Via Asolo, 7 - 36031 Dueville (Vicenza) - ITALY
Phone: +39 0444 361114 - Fax: +39 0444 365247
Email: sales.it@fele.com

Single member - Company subject to the control and coordination of Franklin Electric Co., Inc.

Franklin Electric S.r.l. reserves the right to amend specification without prior notice

00105000 EN_REV.06_08/2019

franklinwater.eu