

MAGNA1

Installation and operating instructions



Original installation and operating instructions

CONTENTS

These installation and operating instructions describe MAGNA1. Sections 1-5 give the information necessary to be able to unpack, install and start up the product in a safe way.

Sections 6-11 give important information about the product, as well as information on service, fault finding and disposal of the product.

	Page
1. General information	2
1.1 Symbols used in this document	2
1.2 Safety symbols on the pump	2
2. Receiving the product	3
2.1 Inspecting the product	3
2.2 Scope of delivery	3
2.3 Lifting the pump	4
3. Installing the product	4
3.1 Location	4
3.2 Tools	4
3.3 Mechanical installation	5
3.4 Electrical installation	8
4. Starting up the product	11
5. Storing and handling the product	11
5.1 Storing the product	11
6. Product introduction	12
6.1 Applications	12
6.2 Pumped liquids	12
6.3 Identification	13
6.4 Insulating shells	13
6.5 Non-return valve	13
7. Control functions	14
7.1 Overview of control functions	15
7.2 Selecting control function	16
7.3 Operating the product	17
7.4 Grundfos Eye	17
7.5 Light fields indicating the pump setting	17
8. Fault finding the product	18
8.1 Grundfos Eye operating status	18
8.2 Fault finding	18
9. Accessories	19
9.1 Insulating kits for air-conditioning and cooling systems	19
9.2 Blanking flanges	19
9.3 Counterflanges	19
9.4 ALPHA plugs	19
10. Technical data	20
11. Disposing of the product	20



Prior to installation, read this document and the quick guide. Installation and operation must comply with local regulations and accepted codes of good practice.

This appliance can be used by children aged from 8 years and above and persons with reduced physical, sensory or mental capabilities or lack of experience and knowledge if they have been given supervision or instruction concerning use of the appliance in a safe way and understand the hazards involved.



Children shall not play with the appliance. Cleaning and user maintenance shall not be made by children without supervision.

1. General information

1.1 Symbols used in this document

**DANGER**

Indicates a hazardous situation which, if not avoided, will result in death or serious personal injury.

**WARNING**

Indicates a hazardous situation which, if not avoided, could result in death or serious personal injury.

**CAUTION**

Indicates a hazardous situation which, if not avoided, could result in minor or moderate personal injury.

The text accompanying the three hazard symbols DANGER, WARNING and CAUTION is structured in the following way:

**SIGNAL WORD****Description of hazard**

Consequence of ignoring the warning.
- Action to avoid the hazard.



A blue or grey circle with a white graphical symbol indicates that an action must be taken.



A red or grey circle with a diagonal bar, possibly with a black graphical symbol, indicates that an action must not be taken or must be stopped.



If these instructions are not observed, it may result in malfunction or damage to the equipment.



Notes or instructions that make the work easier and ensure safe operation.

1.2 Safety symbols on the pump



Check the position of the clamp before you tighten the clamp. Incorrect position of the clamp will cause leakage from the pump and damage the hydraulic parts in the pump head.



Fit and tighten the screw holding the clamp to 8 Nm \pm 1 Nm.



Do not apply more torque than specified even though water is dripping from the clamp. The condensed water is most likely coming from the drain hole under the clamp.

2. Receiving the product

2.1 Inspecting the product

Check that the product is in accordance with the order.
Check that the voltage and frequency of the product match voltage and frequency of the installation site. See section [6.3.1 Nameplate](#).



Pumps tested with water containing anticorrosive additives are taped on the inlet and outlet ports to prevent residual test water from leaking into the packaging. Remove the tape before installing the pump.

2.2 Scope of delivery

2.2.1 Plug-connected single-head pump



Fig. 1 Plug-connected single-head pump

The box contains the following items:

- MAGNA1-pump
- insulating shells
- gaskets
- quick guide
- safety instructions
- one ALPHA plug.

2.2.2 Plug-connected twin-head pump



Fig. 2 Plug-connected twin-head pump

The box contains the following items:

- MAGNA1-pump
- gaskets
- quick guide
- safety instructions
- two ALPHA plugs.

2.2.3 Terminal-connected single-head pump



Fig. 3 Terminal-connected single-head pump

The box contains the following items:

- MAGNA1-pump
- insulating shells
- gaskets
- quick guide
- safety instructions
- box with terminal and cable glands.

2.2.4 Terminal-connected twin-head pump



Fig. 4 Terminal-connected twin-head pump

The box contains the following items:

- MAGNA1-pump
- gaskets
- quick guide
- safety instructions
- two boxes with terminal and cable glands.

TM06 7223 3016

TM05 5508 3016

TM06 6791 3016

TM06 7222 3016

2.3 Lifting the pump



Observe local regulations concerning limits for manual lifting or handling.

Always lift directly on the pump head or the cooling fins when handling the pump. See fig. 5.

For large pumps, it may be necessary to use lifting equipment. Position the lifting straps as illustrated in fig. 5.



Fig. 5 Correct lifting of pump



Do not lift the pump head by the control box, i.e. the red area of the pump. See fig. 6.



Fig. 6 Incorrect lifting of pump

TM05 5819 3016

TM006 7219 3016

3. Installing the product



3.1 Location

The pump is designed for indoor installation.

3.2 Tools

- 1 0.6 x 3.5
- 2 1.2 x 8.0
- 3 TX10
- 4 TX20
- 5 5.0
- 6
- 7
- 8

Fig. 7 Recommended tools

TM05 6472 4712

Pos.	Tool	Size
1	Screwdriver, straight slot	0.6 x 3.5 mm
2	Screwdriver, straight slot	1.2 x 8.0 mm
3	Screwdriver, torx bit	TX10
4	Screwdriver, torx bit	TX20
5	Hexagon key	5.0 mm
6	Side cutter	
7	Open-end spanner	Depending on DN size
8	Pipe wrench	Only used for pumps with unions

3.3 Mechanical installation





The pump range includes both flanged and threaded versions. These installation and operating instructions apply to both versions, but give a general description of flanged versions. If the versions differ, the threaded version will be described separately. Install the pump so that it is not stressed by the pipes. For maximum permissible forces and moments from pipe connections acting on the pump flanges or threaded connections, see page 26.

You can suspend the pump directly in the pipes, provided that the pipes support the pump.

Twin-head pumps are prepared for installation on a mounting bracket or base plate. Pump housing with M12 thread.

To ensure adequate cooling of motor and electronics, observe the following requirements:

- Position the pump in such a way that sufficient cooling is ensured.
- The ambient temperature must not exceed 40 °C.

Step	Action	Illustration
1	Arrows on the pump housing indicate the liquid flow direction through the pump. The liquid flow direction can be horizontal or vertical, depending on the control-box position.	 <p>TM05 5513 3812 TM05 5514 3812</p>
2	Close the isolating valves and make sure that the system is not pressurised during installation of the pump.	 <p>TM05 2863 0612</p>
3	Mount the pump with gaskets in the pipes.	 <p>TM05 5515 3812</p>
4	<p>Flanged version: Fit the bolts, washers and nuts. Use the correct size of bolts according to system pressure. For further information about torques, see page 26.</p> <p>Threaded version: Tighten the union nuts.</p>	 <p>TM05 5516 3816 TM05 5517 3812</p>

3.3.1 Pump positions

Always install the pump with horizontal motor shaft.

- Pump installed correctly in a vertical pipe. See fig. 8, pos. A.
- Pump installed correctly in a horizontal pipe. See fig. 8, pos. B.
- Do not install the pump with vertical motor shaft. See fig. 8, pos. C and D.

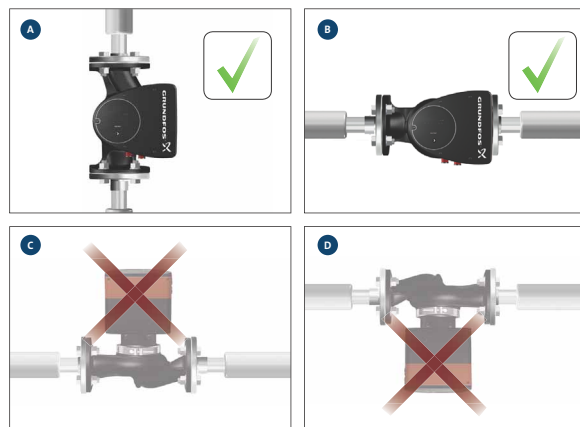

Fig. 8 Pump installed with horizontal motor shaft

3.3.2 Control box positions

To ensure adequate cooling, make sure that the control box is in horizontal position with the Grundfos logo in vertical position. See fig. 9.

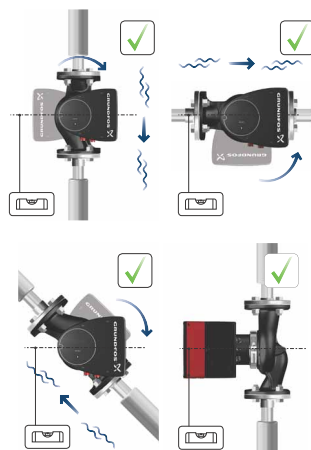

Fig. 9 Pump with control box in horizontal position

! Fit twin-head pumps installed in horizontal pipes with an automatic air vent, Rp 1/4, in the upper part of the pump housing. See fig. 10.



Fig. 10 Automatic vent

TM05 5518 3016

TM05 5522 3016

TM05 6062 3016

3.3.3 Pump head position

If you remove the pump head before installing the pump in the pipes, pay special attention when fitting the pump head to the pump housing:

1. Visually check that the floating ring in the sealing system is centred. See figures 11 and 12.
2. Gently lower the pump head with rotor shaft and impeller into the pump housing.
3. Make sure that the contact face of the pump housing and that of the pump head are in contact before you tighten the clamp. See fig. 13.



Fig. 11 Correctly centred sealing system



Fig. 12 Incorrectly centred sealing system



Check the position of the clamp before you tighten it. Incorrect position of the clamp will cause leakage from the pump and damage the hydraulic parts in the pump head. See fig. 13.

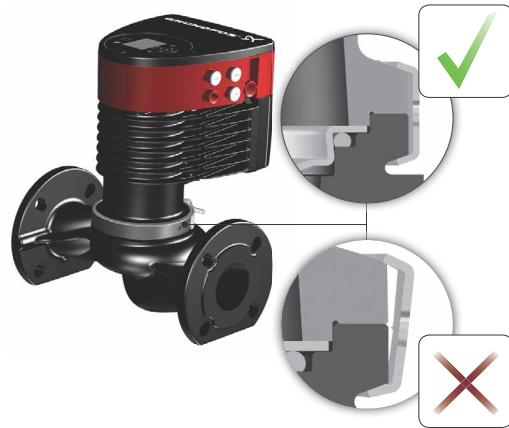

Fig. 13 Fitting the pump head to the pump housing

3.3.4 Changing the control box position



The warning symbol on the clamp holding the pump head and pump housing together indicates that there is a risk of personal injury. See specific warnings below.

CAUTION

Pressurised system

- Minor or moderate personal injury
- Pay special attention to any escaping vapour when loosening the clamp.



CAUTION

Crushing of feet

- Minor or moderate personal injury
- Do not drop the pump head when loosening the clamp.



Fit and tighten the screw holding the clamp to $8 \text{ Nm} \pm 1 \text{ Nm}$. Do not apply more torque than specified even though water is dripping from the clamp. The condensed water is most likely coming from the drain hole under the clamp.





Check the position of the clamp before you tighten the clamp. Incorrect position of the clamp will cause leakage from the pump and damage the hydraulic parts in the pump head.



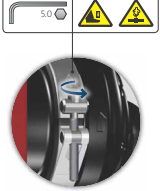

TM05 6650 3016

TM05 6651 3016

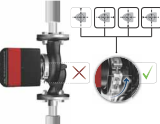
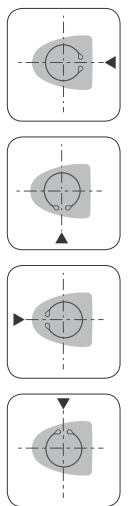
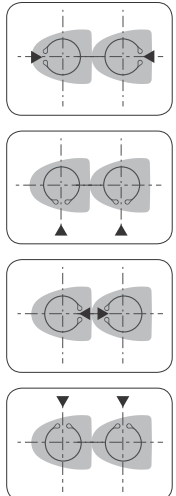
TM05 5837 3016

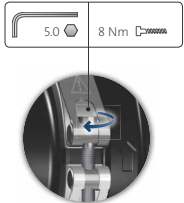
Step	Action	Illustration
1	Loosen the screw in the clamp that holds the pump head and pump housing together. If you loosen the screw too much, the pump head will be completely disconnected from the pump housing.	
2	Carefully turn the pump head to the desired position. If the pump head is stuck, loosen it with a light blow of a rubber mallet.	
3	Place the control box in horizontal position so that the Grundfos logo is in vertical position. The motor shaft must be in horizontal position.	
4	Due to the drain hole in the stator housing, position the gap of the clamp as shown in step 4a or 4b.	
4a	Single-head pump. Position the clamp so that the gap points towards the arrow. It can be in position 3, 6, 9 or 12 o'clock.	
4b	Twin-head pump. Position the clamps so that the gaps point towards the arrows. They can be in position 3, 6, 9 or 12 o'clock.	

Step	Action	Illustration
5	Fit and tighten the screw holding the clamp to 8 ± 1 Nm. Do not retighten the screw if condensed water is dripping from the clamp.	
6	Fit the insulating shells. The insulating shells for pumps in air-conditioning and cooling systems must be ordered separately.	

As an alternative to insulating shells, you can insulate the pump housing and pipes as illustrated in fig. 13.

 Do not insulate the control box or cover the control panel.



Fig. 14 Insulation of pump housing and pipe

TM05 5549 3016

3.4 Electrical installation



Carry out the electrical connection and protection according to local regulations.

Check that the supply voltage and frequency correspond to the values stated on the nameplate.

WARNING



Electric shock

Death or serious personal injury
 - Lock the main switch in position 0. Type and requirements as specified in EN 60204-1, 5.3.2.

WARNING

Electric shock

Death or serious personal injury
 - Connect the pump to an external main switch with a minimum contact gap of 3 mm in all poles.
 - Use earthing or neutralisation for protection against indirect contact.
 - If the pump is connected to an electric installation where an electrical circuit breaker (voltage sensing ELCB, residual-current device RCD or residual-current circuit device RCCB) is used as an additional protection, this circuit breaker must be marked with the first or both of the symbols shown below:



- Make sure that the pump is connected to an external main switch.
- The pump requires no external motor protection.
- The motor incorporates thermal protection against slow overloading and blocking.
- When switched on via the power supply, the pump starts after approximately 5 seconds.

3.4.1 Supply voltage

1 x 230 V ± 10 %, 50/60 Hz, PE.

The voltage tolerances are intended for mains-voltage variations. Do not use the voltage tolerances for running pumps at other voltages than those stated on the nameplate.

3.4.2 Connection to the power supply

Terminal-connected versions

Step	Action	Illustration
1	Remove the front cover from the control box. Do not remove the screws from the cover.	
2	Locate the power supply plug and cable gland in the small cardboard box supplied with the pump.	

Step	Action	Illustration
3	Connect the cable gland to the control box.	
4	Pull the power supply cable through the cable gland.	
5	Strip the cable conductors as illustrated.	
6	Connect the cable conductors to the power supply plug.	
7	Insert the power supply plug into the male plug in the control box.	
8	Tighten the cable gland. Refit the front cover.	

Plug-connected versions

Assembling the plug

Step	Action	Illustration
1	Fit the cable gland and plug cover to the cable. Strip the cable conductors as illustrated.	
2	Connect the cable conductors to the power supply plug.	
3	Bend the cable with the cable conductors pointing upwards.	
4	Pull out the conductor guide plate and throw it away.	
5	Click the plug cover onto the power supply plug.	
6	Screw the cable gland onto the power supply plug.	

Step	Action	Illustration
7	Insert the power supply plug into the male plug in the control box.	

Disassembling the plug

Step	Action	Illustration
1	Loosen the cable gland and remove it from the plug.	
2	Pull off the plug cover while pressing on both sides.	
3	Loosen the cable conductors one by one by pressing a screwdriver gently into the terminal clip.	
4	The plug has now been removed from the power supply plug.	

3.4.3 Connection diagrams

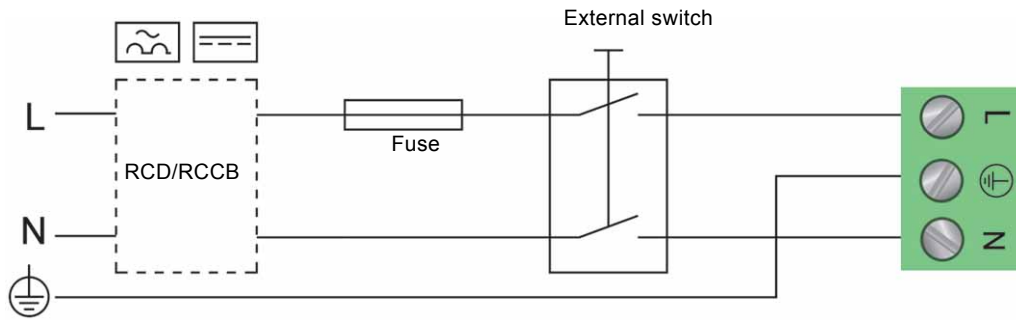

Fig. 15 Example of a mains-connected motor with main switch, backup fuse and additional protection

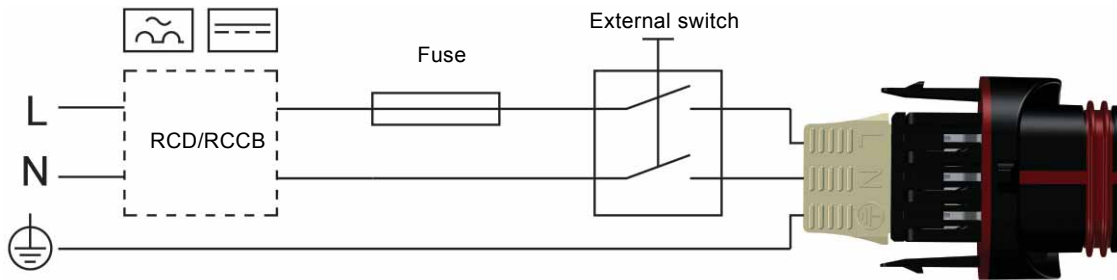

Fig. 16 Example of a plug-connected motor with main switch, backup fuse and additional protection



Make sure that the fuse is dimensioned according to the nameplate and local regulations.



Connect all cables in accordance with local regulations.



Make sure that all cables are heat-resistant up to 75 °C.
Install all cables in accordance with EN 60204-1 and EN 50174-2:2000.

TM03 2397 3016

TM05 5277 3016

4. Starting up the product



The number of starts and stops via the power supply must not exceed four times per hour.

Do not start the pump until the system has been filled with liquid and vented. Furthermore, the required minimum inlet pressure must be available at the pump inlet. See section 10. [Technical data](#).

The pump is self-venting through the system, and the system must be vented at the highest point.

Step	Action	Illustration
1	Switch on the power supply to the pump. The pump starts after approximately 5 seconds.	<p>1 x 230 V ± 10% -50/60 Hz</p>
2	Control panel at first startup.	
3	The pump has been factory-set to the intermediate proportional-pressure curve. Select the control mode according to the system application.	

TM05 5550 3016

TM05 5551 3016

TM05 5551 3016

5. Storing and handling the product

5.1 Storing the product

5.1.1 Frost protection



If the pump is not used during periods of frost, take the necessary steps to prevent frost bursts.

6. Product introduction



Grundfos MAGNA1 is a complete range of circulator pumps with integrated controller enabling adjustment of pump performance to the actual system requirements. In many systems, this reduces the power consumption considerably, reduces noise from thermostatic radiator valves and similar fittings and improves the control of the system.

You can set the desired head on the control panel.

6.1 Applications

The pump is designed for circulating liquids in the following systems:

- heating systems
- domestic hot-water systems
- air-conditioning and cooling systems.

You can also use the pump in the following systems:

- ground source heat pump systems
- solar heating systems.

6.2 Pumped liquids

The pump is suitable for thin, clean, non-aggressive and non-explosive liquids, not containing solid particles or fibres that may attack the pump mechanically or chemically.

In heating systems, the water must meet the requirements of accepted standards on water quality in heating systems, for example the German standard VDI 2035.

The pumps are also suitable for domestic hot-water systems.



Observe local regulation regarding pump-housing material.

We strongly recommend that you use stainless-steel pumps in domestic hot-water applications to avoid corrosion.

In domestic hot-water systems, we recommend that you use the pump only for water with a degree of hardness lower than approximately 14 °dH.

In domestic hot-water systems, we recommend that you keep the liquid temperature below 65 °C to eliminate the risk of lime precipitation.



Do not pump aggressive liquids.



Do not pump flammable, combustible or explosive liquids.

6.2.1 Glycol

You can use the pump for pumping water-ethylene-glycol mixtures up to 50 %.

Example of a water-ethylene-glycol mixture:

Maximum viscosity: 50 cSt ~ 50 % water / 50 % glycol mixture at -10 °C.

The pump has a power-limiting function that protects it against overload.

The pumping of glycol mixtures affects the maximum curve and reduces the performance, depending on the water-ethylene-glycol mixture and the liquid temperature.

To prevent the glycol mixture from degrading, avoid temperatures exceeding the rated liquid temperature and minimise the operating time at high temperatures.

Clean and flush the system before you add the glycol mixture.

To prevent corrosion or lime precipitation, check and maintain the glycol mixture regularly. If further dilution of the supplied glycol is required, follow the glycol supplier's instructions.



Additives with a density and/or kinematic viscosity higher than those/that of water reduce the hydraulic performance



Fig. 17 Pumped liquids

You can connect the pump to the power supply in two ways, that is via terminals and via plug. These options are available for both flanged and threaded versions.

6.3 Identification

6.3.1 Nameplate

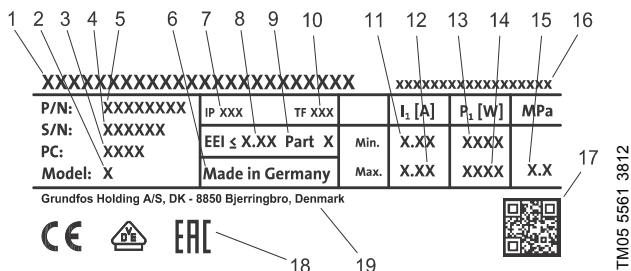

Fig. 18 Example of nameplate

Pos.	Description
1	Product name
2	Model
3	Production code, PC, year and week*
4	Serial number
5	Product number
6	Country of manufacture
7	Enclosure class
8	Energy Efficiency Index, EEI
9	Part, according to EEI
10	Temperature class
11	Minimum current [A]
12	Maximum current [A]
13	Minimum power [W]
14	Maximum power [W]
15	Maximum system pressure
16	Voltage [V] and frequency [Hz]
17	QR code
18	CE mark and approvals

* Example of production code: 1326. The pump was produced in week 26, 2013.



Fig. 19 Production code on packaging

6.4 Insulating shells

Insulating shells are available for single-head pumps only.



Limit the heat loss from the pump housing and pipes.

Reduce the heat loss from the pump and pipes by insulating the pump housing and the pipes. See fig. 20.

- Insulating shells for pumps in heating systems are supplied with the pump.
- Insulating shells for pumps in air-conditioning and cooling systems, down to -10 °C, are available as accessories and must be ordered separately. See section 9.1 *Insulating kits for air-conditioning and cooling systems*.

Insulating shells increases the pump dimensions.



Fig. 20 Insulating shells

Pumps for heating systems are factory-fitted with insulating shells. Remove the insulating shells before you install the pump.

6.5 Non-return valve

If a non-return valve is fitted in the pipe system, ensure that the set minimum outlet pressure of the pump is always higher than the closing pressure of the valve. See fig. 21. This is especially important in proportional-pressure control mode with reduced head at low flow.

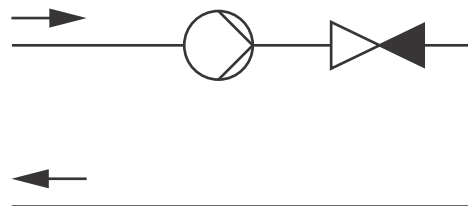

Fig. 21 Non-return valve

TM05 5512 3016

TM05 3055 0912

TM06 6692 2216

7. Control functions

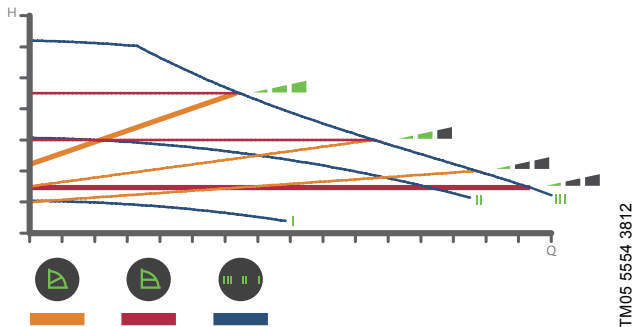

Fig. 22 Selection of pump setting for system type

Factory setting: Intermediate proportional-pressure curve, referred to as PP2.

Proportional-pressure curve (PP1, PP2 or PP3)

Proportional-pressure control adjusts the pump performance to the actual heat demand in the system, but the pump performance follows the selected performance curve, PP1, PP2 or PP3. See fig. 23 where PP2 has been selected. For further information, see section 8. *Fault finding the product*.

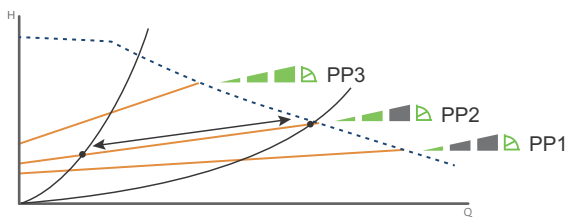

Fig. 23 Three proportional-pressure curves/settings

The selection of the right proportional-pressure setting depends on the characteristics of the heating system in question and the actual heat demand.

Constant-pressure curve (CP1, CP2 or CP3)

Constant-pressure control adjusts the pump performance to the actual heat demand in the system, but the pump performance follows the selected performance curve, CP1, CP2 or CP3. See fig. 24 where CP1 has been selected. For further information, see section 8. *Fault finding the product*.

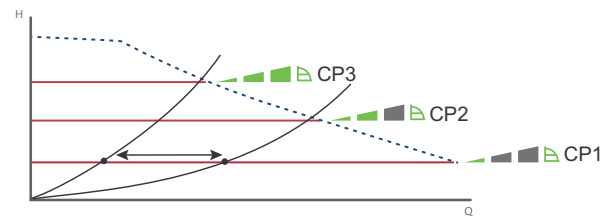

Fig. 24 Three constant-pressure curves/settings

The selection of the right constant-pressure setting depends on the characteristics of the heating system in question and the actual heat demand.

Constant curve (I, II or III)

At constant-curve operation, the pump runs at a constant speed, independent of the actual flow demand in the system. The pump performance follows the selected performance curve, I, II or III. See fig. 25 where II has been selected. For further information, see section 8. *Fault finding the product*.

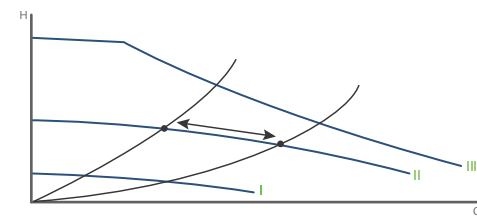
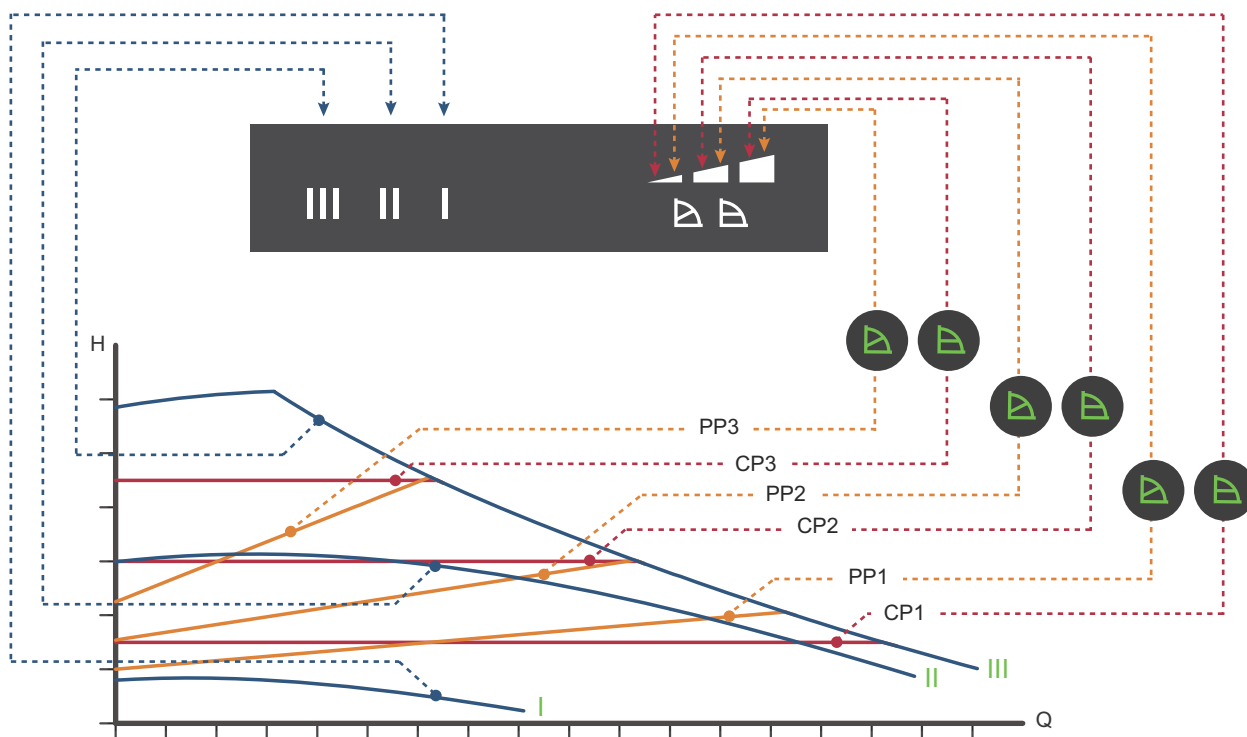

Fig. 25 Three constant-curve settings

The selection of the right constant-curve setting depends on the characteristics of the heating system in question.

7.1 Overview of control functions



TMO5 2777 0512

Fig. 26 Pump setting in relation to pump performance

Setting	Pump curve	Function
PP1	Lowest proportional-pressure curve	The duty point of the pump will move up or down on the lowest proportional-pressure curve, depending on the heat demand. See fig. 26. The head is reduced at falling heat demand and increased at rising heat demand.
PP2	Intermediate proportional-pressure curve	The duty point of the pump will move up or down on the intermediate proportional-pressure curve, depending on the heat demand. See fig. 26. The head is reduced at falling heat demand and increased at rising heat demand.
PP3	Highest proportional-pressure curve	The duty point of the pump will move up or down on the highest proportional-pressure curve, depending on the heat demand. See fig. 26. The head is reduced at falling heat demand and increased at rising heat demand.
CP1	Lowest constant-pressure curve	The duty point of the pump will move out or in on the lowest constant-pressure curve, depending on the heat demand in the system. See fig. 26. The head is kept constant, irrespective of the heat demand.
CP2	Intermediate constant-pressure curve	The duty point of the pump will move out or in on the intermediate constant-pressure curve, depending on the heat demand in the system. See fig. 26. The head is kept constant, irrespective of the heat demand.
CP3	Highest constant-pressure curve	The duty point of the pump will move out or in on the highest constant-pressure curve, depending on the heat demand in the system. See fig. 26. The head is kept constant, irrespective of the heat demand.
III	Speed III	The pump runs on a constant curve which means that it runs at a constant speed. At speed III, the pump is set to run on the maximum curve under all operating conditions. See fig. 26. You obtain quick venting of the pump by setting the pump to speed III for a short period.
II	Speed II	The pump runs on a constant curve which means that it runs at a constant speed. At speed II, the pump is set to run on the intermediate curve under all operating conditions. See fig. 26.
I	Speed I	The pump runs on a constant curve which means that it runs at a constant speed. At speed I, the pump is set to run on the minimum curve under all operating conditions. See fig. 26.

7.2 Selecting control function

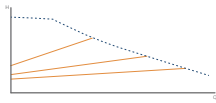
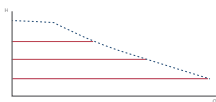
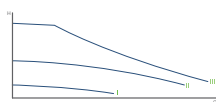
System application	Select this control mode
<p>In systems with relatively large pressure losses in the distribution pipes and in air-conditioning and cooling systems.</p> <ul style="list-style-type: none"> • Two-pipe heating systems with thermostatic valves and the following: <ul style="list-style-type: none"> – very long distribution pipes – strongly throttled pipe balancing valves – differential-pressure regulators – large pressure losses in those parts of the system through which the total quantity of water flows, for example boiler, heat exchanger and distribution pipe up to the first branching. • Primary circuit pumps in systems with large pressure losses in the primary circuit. • Air-conditioning systems with the following: <ul style="list-style-type: none"> – heat exchangers, fan coils – cooling ceilings – cooling surfaces. 	<p>Proportional pressure</p> 
<p>In systems with relatively small pressure losses in the distribution pipes.</p> <ul style="list-style-type: none"> • Two-pipe heating systems with thermostatic valves and the following: <ul style="list-style-type: none"> – dimensioned for natural circulation – small pressure losses in those parts of the system through which the total quantity of water flows, for example boiler, heat exchanger and distribution pipe up to the first branching or modified to a high differential temperature between flow pipe and return pipe, for example district heating. • Underfloor heating systems with thermostatic valves. • One-pipe heating systems with thermostatic valves or pipe balancing valves. • Primary circuit pumps in systems with small pressure losses in the primary circuit. 	<p>Constant pressure</p> 
<p>You can also set the pump to operate according to the maximum or minimum curve, like an uncontrolled pump:</p> <ul style="list-style-type: none"> • Use the maximum-curve mode in periods in which a maximum flow is required. This operating mode is for instance suitable for hot-water priority in domestic hot-water systems. • Use the minimum-curve mode in periods in which a minimum flow is required. 	<p>Constant curve</p> 

7.3 Operating the product

CAUTION
Hot surface
 Minor or moderate personal injury
 - Only touch the control panel to avoid burns.

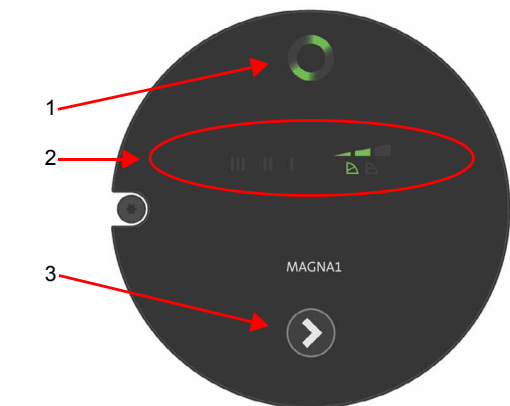

Fig. 27 Control panel

Pos.	Description
1	Operating status of Grundfos Eye. See section 7.4 Grundfos Eye .
2	Eight light fields indicating the pump setting. See section 7.5 Light fields indicating the pump setting .
3	Push-button for selection of pump setting.

7.4 Grundfos Eye

Grundfos Eye is on when you switch on the power supply. See fig. 27, pos. 1.

Grundfos Eye is an indicator light providing information about the actual pump status.

The indicator light flashes in different sequences and provides information about the following:

- power on and off
- pump alarms.

The function of Grundfos Eye is described in section [8.1 Grundfos Eye operating status](#).

Faults preventing the pump from operating properly, for example blocked rotor, are indicated by Grundfos Eye. See section [8.1 Grundfos Eye operating status](#).

If a fault is indicated, correct the fault and reset the pump by switching the power supply off and on.

If the pump impeller is rotated, for example when filling the pump with water, sufficient energy may be generated to light up the control panel even if the power supply has been switched off.

7.5 Light fields indicating the pump setting

The pump has nine performance settings which you can select with the push-button. See fig. 27, pos. 3.

The pump setting is indicated by eight light fields in the display. See fig. 27, pos. 2.



Fig. 28 Factory setting, PP2



Button presses	Active light fields	Description
0		Intermediate proportional-pressure curve, referred to as PP2
1		Highest proportional-pressure curve, referred to as PP3
2		Lowest constant-pressure curve, referred to as CP1
3		Intermediate constant-pressure curve, referred to as CP2
4		Highest constant-pressure curve, referred to as CP3
5		Constant curve III
6		Constant curve II
7		Constant curve I
8		Lowest proportional-pressure curve, referred to as PP1

TM05 5552 3812

TM05 5553 3812

8. Fault finding the product

8.1 Grundfos Eye operating status

Grundfos Eye	Indication	Cause
	No lights are on.	The power is off. The pump is not running.
	Two opposite green indicator lights running in the direction of rotation of the pump.	The power is on. The pump is running.
	Two opposite red indicator lights flashing simultaneously.	Alarm. The pump is stopped.

8.2 Fault finding

Reset a fault indication in one of the following ways:

- When you have eliminated the fault cause, the pump reverts to normal duty.
- If the fault disappears by itself, the fault indication is automatically reset.

CAUTION

Pressurised system

- Minor or moderate personal injury
- Before dismantling the pump, drain the system or close the isolating valve on either side of the pump. The pumped liquid may be scalding hot and under high pressure.



WARNING

Electric shock

- Death or serious personal injury.
- Switch off the power supply for at least 3 minutes before you start any work on the product. Lock the main switch in position 0. Type and requirements as specified in EN 60204-1, 5.3.2.



WARNING

Electric shock

- Death or serious personal injury.
- Make sure that other pumps or sources do not force flow through the pump even if the pump is stopped.



- If the power supply cable is damaged, it must be replaced by the manufacturer, the manufacturer's service partner or a similarly qualified person.

Fault	Automatic reset and restart?	Corrective actions
Other pumps or sources force flow through the pump even if the pump is stopped. There is light in the display even if the power supply is switched off.	Yes	Check the system for defective non-return valves and replace the valves, if necessary. Check the system for correct position of non-return valves.
The supply voltage to the pump is too low.	Yes	Check that the power supply is within the specified range.
The pump is blocked.	No	Dismantle the pump and remove any foreign matter or impurities preventing the pump from rotating. Check the water quality to eliminate the risk of lime precipitation.
No water at the pump inlet, or the water contains too much air.	No	Prime and vent the pump before a new startup. Check that the pump is operating correctly. If not, replace the pump, or contact Grundfos Service.
Fault in the pump electronics.	Yes	Replace the pump, or contact Grundfos Service.
The supply voltage to the pump is too high.	Yes	Check that the power supply is within the specified range.

9. Accessories



9.1 Insulating kits for air-conditioning and cooling systems

You can fit single-head pumps for air-conditioning and cooling systems with insulating shells. A kit consists of two shells made of polyurethane and a self-adhesive seal to ensure tight assembly.

The dimensions of the insulating shells for pumps in air-conditioning and cooling systems differ from those of the insulating shells for pumps in heating systems.

Pump type	Product number
MAGNA1 25-40/60/80/100/120 (N)	98538852
MAGNA1 32-40/60/80/100 (N)	98538853
MAGNA1 32-40/60/80/100 F (N)	98538854
MAGNA1 32-120 F (N)	98164595
MAGNA1 40-40/60 F (N)	98538855
MAGNA1 40-80/100 F (N)	98164597
MAGNA1 40-120/150/180 F (N)	98164598
MAGNA1 50-40/60/80 F (N)	98164599
MAGNA1 50-100/120/150/180 F (N)	98164600
MAGNA1 65-40/60/80/100/120/150 F (N)	98538839
MAGNA1 80-40/60/80/100/120 F	98538851
MAGNA1 100-40/60/80/100/120 F	98164611



The insulating kit also fits stainless-steel versions (N).

9.2 Blanking flanges

A blanking flange is used to blank off the opening when one of the pumps of a twin-head pump is removed for service to enable uninterrupted operation of the other pump.

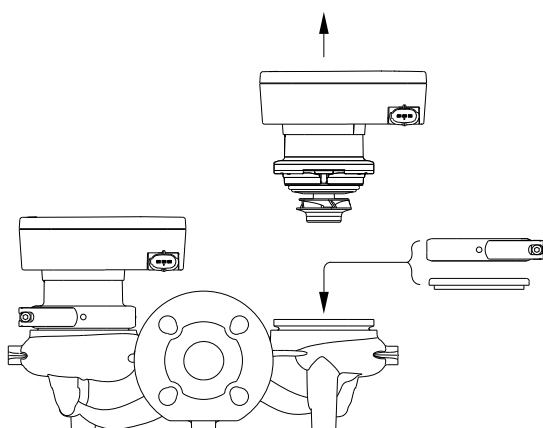

Fig. 29 Position of blanking flange

Pump type	Product number
MAGNA1 D 32-40/60/80/100 (F)	98159373
MAGNA1 D 40-40/60 F	
MAGNA1 D 32-120 F	98159372
MAGNA1 D 40-80/100/120/150/180 F	
MAGNA1 D 50-40/60/80/100/120/150/180 F	
MAGNA1 D 65-40/60/80/100/120/150 F	
MAGNA1 D 80-40/60/80/100/120 F	
MAGNA1 D 100-40/60/80/100/120 F	

9.3 Counterflanges

Counterflange kits consist of two flanges, two gaskets and bolts and nuts, making it possible to install the pump in any pipes. See [MAGNA1 data booklet](#), *Accessories* section, for the right dimension and product number.

9.4 ALPHA plugs

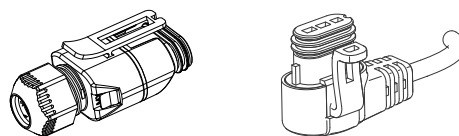

Fig. 30 ALPHA plugs

Description	Product number
ALPHA plug with cable relief	97928845
ALPHA plug, angled, with 4 m cable	96884669
ALPHA plug, angled, with inrush protection with 1 m cable	97844632

TM05 2677 - 2676 0312

TM05 5525 3812

10. Technical data

Supply voltage

1 x 230 V ± 10 %, 50/60 Hz, PE.

Motor protection

The pump requires no external motor protection.

Enclosure class

IPX4D (EN 60529).

Insulation class

F.

Relative air humidity

Maximum 95 %.

Ambient temperature

0 to 40 °C.

During transport: -40 to +70 °C.

Temperature class

TF110 (EN 60335-2-51).

Liquid temperature

Continuously: -10 to +110 °C.

Stainless steel pumps in domestic hot-water systems:

In domestic hot-water systems, we recommend that you keep the liquid temperature below 65 °C to eliminate the risk of lime precipitation.

System pressure



The actual inlet pressure and the pump pressure against a closed valve must be lower than the maximum permissible system pressure.

The maximum permissible system pressure is stated on the pump nameplate:

PN 6: 6 bar or 0.6 MPa

PN 10: 10 bar or 1.0 MPa

PN 16: 16 bar or 1.6 MPa.

Test pressure

The pumps can withstand test pressures as indicated in EN 60335-2-51.

- PN 6: 7.2 bar
- PN 10: 12 bar
- PN 6/10: 12 bar
- PN 16: 19.2 bar.

During normal operation, do not use the pump at higher pressures than those stated on the nameplate. See fig. 18.

The pressure test has been made with water containing anti-corrosive additives at a temperature of 20 °C.

Minimum inlet pressure

The following relative minimum inlet pressure must be available at the pump inlet during operation to avoid cavitation noise and damage to the pump bearings.



The values in the table below apply to single-head pumps and twin-head pumps in single-head operation.

Single-head pumps DN	Liquid temperature		
	75 °C	95 °C	110 °C
	Inlet pressure [bar] / [MPa]		
25-40/60/80/100/120	0.10 / 0.01	0.35 / 0.035	1.0 / 0.10
32-40/60/80/100/120	0.10 / 0.01	0.35 / 0.035	1.0 / 0.10
32-120 F	0.10 / 0.01	0.20 / 0.020	0.7 / 0.07
40-40/60 F	0.10 / 0.01	0.35 / 0.035	1.0 / 0.10
40-80/100/120/150/180 F	0.10 / 0.01	0.50 / 0.05	1.0 / 0.10
50-40/60/80 F	0.10 / 0.01	0.40 / 0.04	1.0 / 0.10
50-100/128 F	0.10 / 0.01	0.50 / 0.05	1.0 / 0.10
50-150/180 F	0.70 / 0.07	1.20 / 0.12	1.7 / 0.17
65-40/60/80/100/120/150 F	0.70 / 0.07	1.20 / 0.12	1.7 / 0.17
80-40/60/80/100/120 F	0.50 / 0.05	1.00 / 0.10	1.5 / 0.15
100-40/60/80/100/120 F	0.70 / 0.07	1.20 / 0.12	1.7 / 0.17

In the case of twin-head operation, increase the required relative inlet pressure by 0.1 bar or 0.01 MPa compared to the stated values for single-head pumps or twin-head pumps in single-head operation.



The actual inlet pressure and the pump pressure against a closed valve must be lower than the maximum permissible system pressure.

The relative minimum inlet pressures apply to pumps installed up to 300 metres above sea level. For altitudes above 300 metres, increase the required relative inlet pressure by 0.01 bar or 0.001 MPa per 100 metres altitude. The pump is only approved for an altitude of maximum 2000 metres above sea level.

Sound pressure level

The sound pressure level of the pump is lower than 43 dB(A).

Leakage current

The mains filter will cause a leakage current to earth during operation. The leakage current is less than 3.5 mA.

Power factor

The terminal-connected versions have a built-in active power factor correction which gives a $\cos \phi$ from 0.98 to 0.99.

The plug-connected versions have a built-in passive power factor correction with coil and resistors which ensure that the current drawn from the grid is in phase with the voltage and that the current is approximately sinusoidal which gives a $\cos \phi$ from 0.55 to 0.98.

11. Disposing of the product

This product has been designed with focus on the disposal and recycling of materials. The following average disposal values apply to all variants of MAGNA1 pumps:

- 85 % recycling
- 10 % incineration
- 5 % depositing.

Dispose of this product or parts of it in an environmentally sound way according to local regulations.

For further information, see the end-of-life information on www.grundfos.com.

Subject to alterations.

1. Dimensions

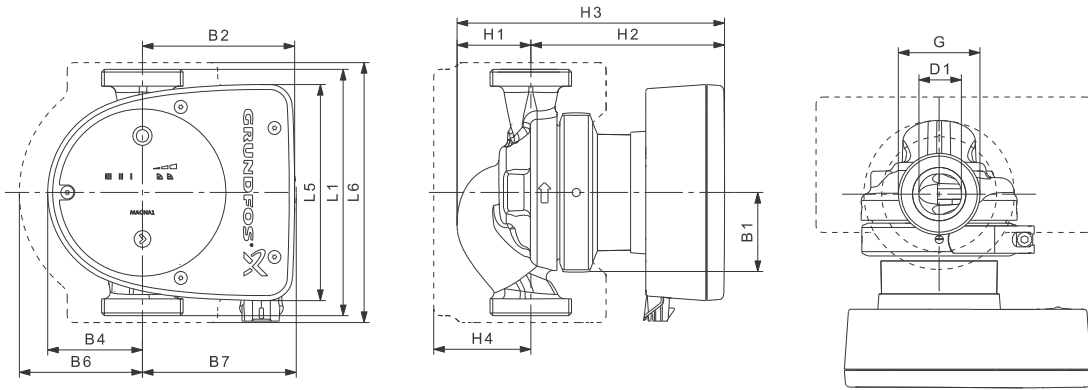

TM05 5142 3512

Fig. 1 Single-head pump dimensions, threaded version

Pump type	Dimensions [mm]													[inch]	
	L1	L5	L6	B1	B2	B4	B6	B7	H1	H2	H3	H4	D1	G	
MAGNA1 25-40 (N)	180	158	190	58	111	69	90	113	54	142	196	71	25	1 1/2	
MAGNA1 25-60 (N)	180	158	190	58	111	69	90	113	54	142	196	71	25	1 1/2	
MAGNA1 25-80 (N)	180	158	190	58	111	69	90	113	54	142	196	71	25	1 1/2	
MAGNA1 25-100 (N)	180	158	190	58	111	69	90	113	54	142	196	71	25	1 1/2	
MAGNA1 25-120 (N)	180	158	190	58	111	69	90	113	54	142	196	71	25	1 1/2	
MAGNA1 32-40 (N)	180	158	190	58	111	69	90	113	54	142	196	71	32	2	
MAGNA1 32-60 (N)	180	158	190	58	111	69	90	113	54	142	196	71	32	2	
MAGNA1 32-80 (N)	180	158	190	58	111	69	90	113	54	142	196	71	32	2	
MAGNA1 32-100 (N)	180	158	190	58	111	69	90	113	54	142	196	71	32	2	
MAGNA1 32-120 (N)	180	158	190	58	111	69	90	113	54	142	196	71	32	2	

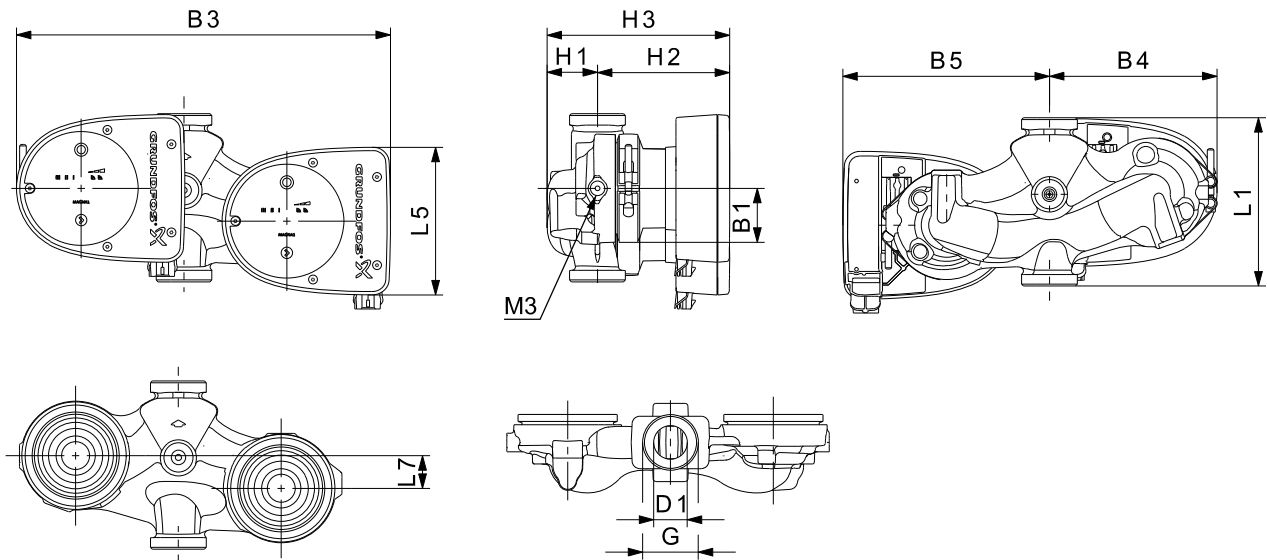

TM05 5201 3512

Fig. 2 Twin-head pump dimensions, threaded version

Pump type	Dimensions [mm]													[inch]	
	L1	L5	L7	B1	B3	B4	B5	H1	H2	H3	D1	G	M3		
MAGNA1 D 32-40	180	158	35	58	400	179	221	54	142	196	32	2	1/4		
MAGNA1 D 32-60	180	158	35	58	400	179	221	54	142	196	32	2	1/4		
MAGNA1 D 32-80	180	158	35	58	400	179	221	54	142	196	32	2	1/4		
MAGNA1 D 32-100	180	158	35	58	400	179	221	54	142	196	32	2	1/4		

2. Dimensions

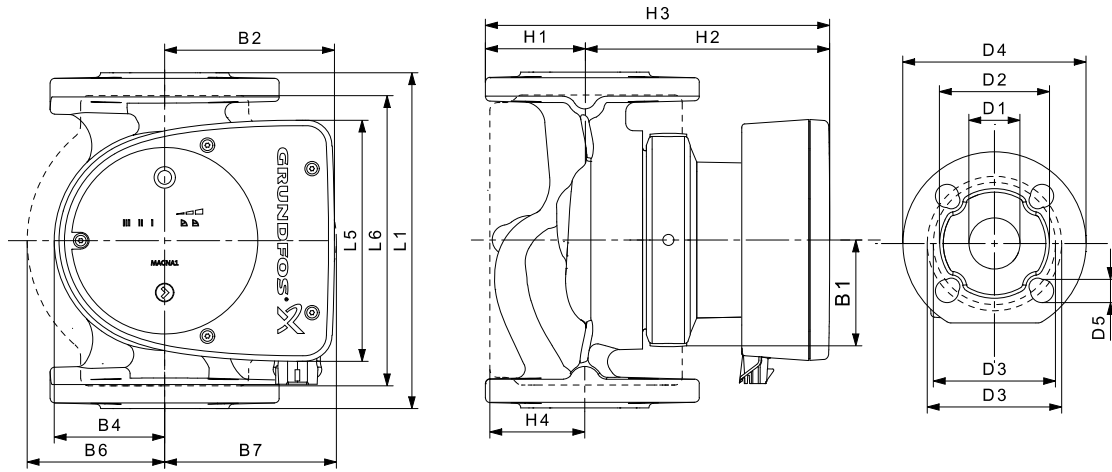

Fig. 3 Single-head pump dimensions, plug-connected versions, flanged version

TM05 5200 3412

Pump type	Dimensions [mm]																
	L1	L5	L6	B1	B2	B4	B6	B7	H1	H2	H3	H4	D1	D2	D3	D4	D5
MAGNA1 32-40 F (N)	220	158	220	58	111	69	100	110	65	142	207	82	32	76	90/100	140	14/19
MAGNA1 32-60 F (N)	220	158	220	58	111	69	100	110	65	142	207	82	32	76	90/100	140	14/19
MAGNA1 32-80 F (N)	220	158	220	58	111	69	100	110	65	142	207	82	32	76	90/100	140	14/19
MAGNA1 32-100 F (N)	220	158	220	58	111	69	100	110	65	142	207	82	32	76	90/100	140	14/19
MAGNA1 40-40 F (N)	220	158	220	58	111	69	105	105	65	156	221	83	40	84	100/110	150	14/19
MAGNA1 40-60 F (N)	220	158	220	58	111	69	105	105	65	156	221	83	40	84	100/110	150	14/19

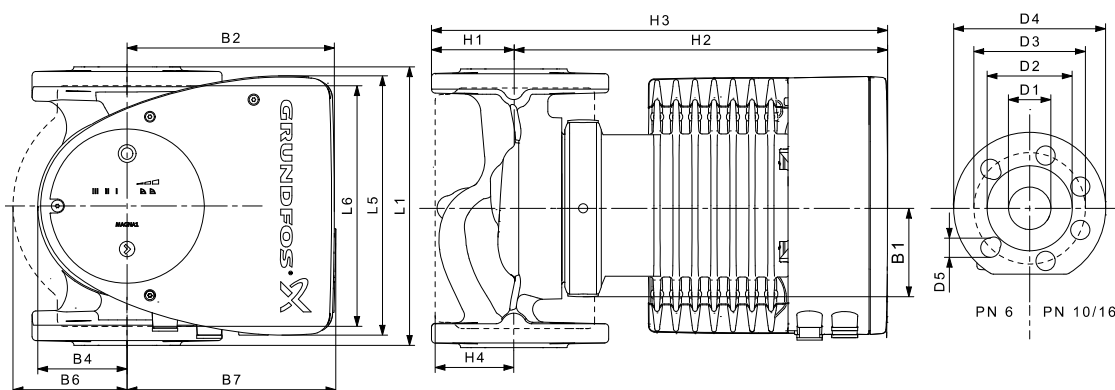

Fig. 4 Single-head pump dimensions, terminal-connected versions, flanged version

TMM05 5276 3512

Pump type	Dimensions [mm]																
	L1	L5	L6	B1	B2	B4	B6	B7	H1	H2	H3	H4	D1	D2	D3	D4	D5
MAGNA1 32-120 F (N)	220	204	216	84	164	73	106	116	65	301	366	86	32	76	90/100	140	14/19
MAGNA1 40-80 F (N)	220	204	220	84	164	73	106	128	65	304	369	83	40	84	100/110	150	14/19
MAGNA1 40-100 F (N)	220	204	220	84	164	73	106	128	65	304	369	83	40	84	100/110	150	14/19
MAGNA1 40-120 F (N)	250	204	220	84	164	73	106	128	65	304	369	83	40	84	100/110	150	14/19
MAGNA1 40-150 F (N)	250	204	220	84	164	73	106	128	65	304	369	83	40	84	100/110	150	14/19
MAGNA1 40-180 F (N)	250	204	220	84	164	73	106	128	65	304	369	83	40	84	100/110	150	14/19
MAGNA1 50-40 F (N)	240	204	240	84	164	73	127	127	71	304	374	97	50	102	110/125	165	14/19
MAGNA1 50-60 F (N)	240	204	240	84	164	73	127	127	71	304	374	97	50	102	110/125	165	14/19
MAGNA1 50-80 F (N)	240	204	240	84	164	73	127	127	71	304	374	97	50	102	110/125	165	14/19
MAGNA1 50-100 F (N)	280	204	240	84	164	73	127	127	72	304	376	97	50	102	110/125	165	14/19
MAGNA1 50-120 F (N)	280	204	240	84	164	73	127	127	72	304	376	97	50	102	110/125	165	14/19
MAGNA1 50-150 F (N)	280	204	240	84	164	73	127	127	72	304	376	97	50	102	110/125	165	14/19
MAGNA1 50-180 F (N)	280	204	240	84	164	73	127	127	72	304	376	97	50	102	110/125	165	14/19
MAGNA1 65-40 F (N)	340	204	296	84	164	73	133	133	74	312	386	94	65	119	130/145	185	14/19
MAGNA1 65-60 F (N)	340	204	296	84	164	73	133	133	74	312	386	94	65	119	130/145	185	14/19
MAGNA1 65-80 F (N)	340	204	296	84	164	73	133	133	74	312	386	94	65	119	130/145	185	14/19
MAGNA1 65-100 F (N)	340	204	296	84	164	73	133	133	74	312	386	94	65	119	130/145	185	14/19
MAGNA1 65-120 F (N)	340	204	296	84	164	73	133	133	74	312	386	94	65	119	130/145	185	14/19
MAGNA1 65-150 F (N)	340	204	296	84	164	73	133	133	74	312	386	94	65	119	130/145	185	14/19
MAGNA1 80-40 F	360	204	310	84	164	73	163	163	96	318	413	115	80	128	150/160	200	19
MAGNA1 80-60 F	360	204	310	84	164	73	163	163	96	318	413	115	80	128	150/160	200	19
MAGNA1 80-80 F	360	204	310	84	164	73	163	163	96	318	413	115	80	128	150/160	200	19
MAGNA1 80-100 F	360	204	310	84	164	73	163	163	96	318	413	115	80	128	150/160	200	19
MAGNA1 80-120 F	360	204	310	84	164	73	163	163	96	318	413	115	80	128	150/160	200	19
MAGNA1 100-40 F	450	204	396	84	164	73	178	178	103	330	433	120	100	160	170	220	19
MAGNA1 100-60 F	450	204	396	84	164	73	178	178	103	330	433	120	100	160	170	220	19
MAGNA1 100-80 F	450	204	396	84	164	73	178	178	103	330	433	120	100	160	170	220	19
MAGNA1 100-100 F	450	204	396	84	164	73	178	178	103	330	433	120	100	160	170	220	19
MAGNA1 100-120 F	450	204	396	84	164	73	178	178	103	330	433	120	100	160	170	220	19

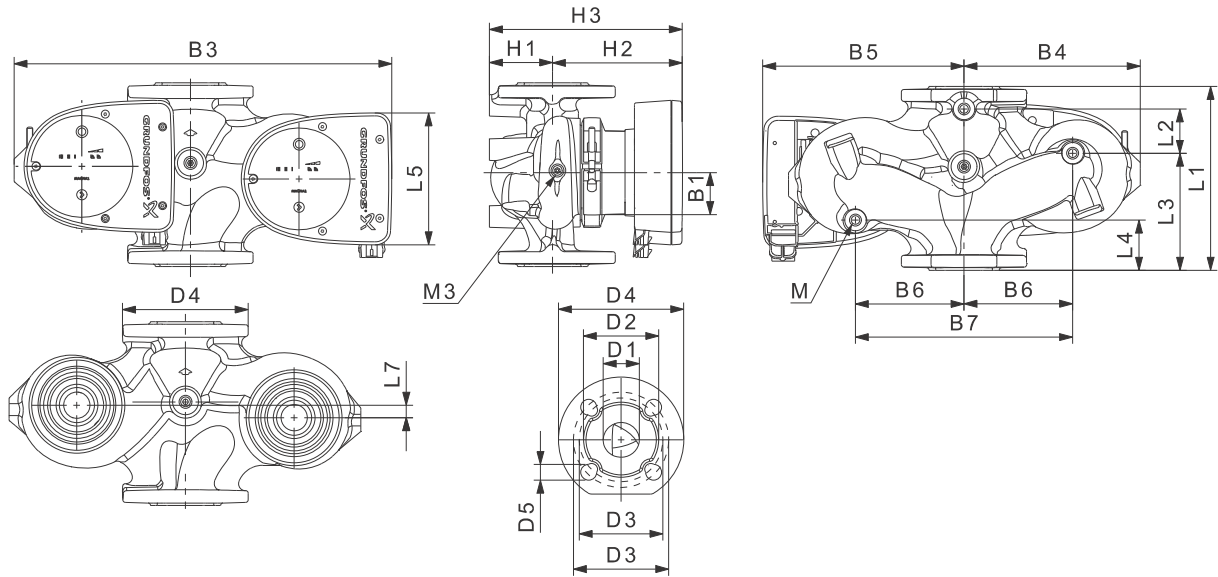

Fig. 5 Twin-head pump dimensions, plug-connected versions, flanged version

TM05 4960 3012

Pump type	Dimensions [mm]																				
	L1	L2	L3	L4	L5	L7	B1	B3	B4	B5	B6	B7	H1	H2	H3	D1	D2	D3	D4	D5	M
MAGNA1 D 32-40 F	220	73	120	85	158	35	58	400	179	221	130	260	69	142	211	32	76	90/100	140	14/19	12
MAGNA1 D 32-60 F	220	73	120	85	158	35	58	400	179	221	130	260	69	142	211	32	76	90/100	140	14/19	12
MAGNA1 D 32-80 F	220	73	120	85	158	35	58	400	179	221	130	260	69	142	211	32	76	90/100	140	14/19	12
MAGNA1 D 40-40 F	220	53	140	60	158	15	58	452	211	241	130	260	76	156	232	40	84	100/110	150	14/19	12
MAGNA1 D 40-60 F	220	53	140	60	158	15	58	452	211	241	130	260	76	156	232	40	84	100/110	150	14/19	12
MAGNA1 D 40-80 F	220	53	140	60	204	15	84	502	210	294	130	260	76	303	379	40	84	100/110	150	14/19	12

Note M3: Rp 1/4 for air vent available on all twin-head pumps.

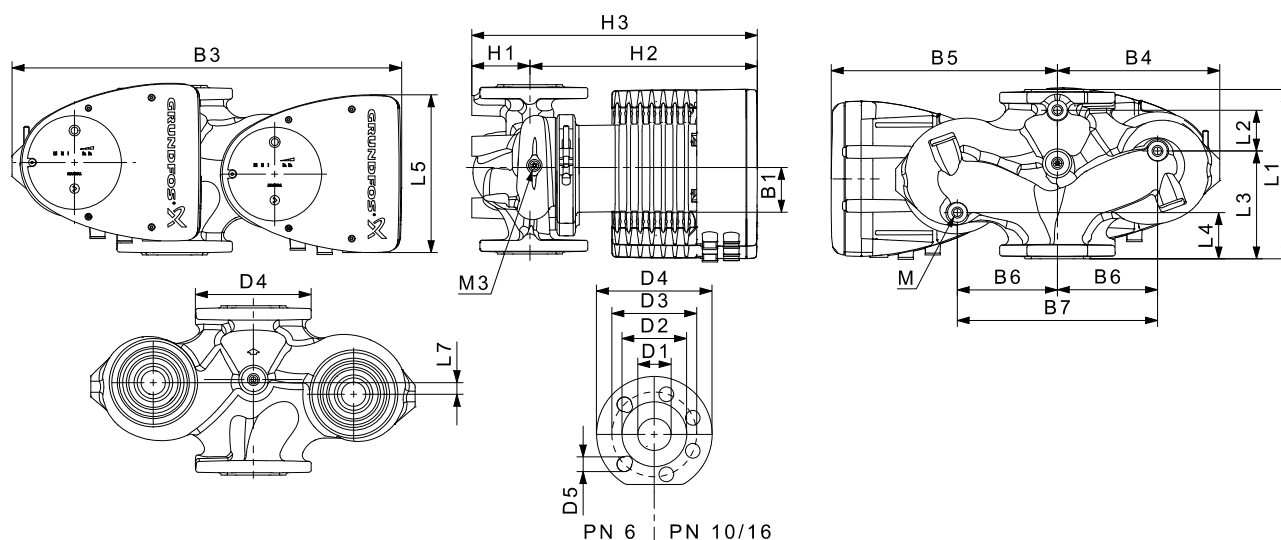

Fig. 6 Twin-head pump dimensions, terminal connected versions (flanged version)

TM05 5275 3512

Pump type	Dimensions [mm]																				
	L1	L2	L3	L4	L5	L7	B1	B3	B4	B5	B6	B7	H1	H2	H3	D1	D2	D3	D4	D5	M
MAGNA1 D 32-120 F	220	97	90	50	204	50	84	502	210	294	130	260	68	300	368	32	76	90/100	140	14/19	12
MAGNA1 D 40-80 F	220	53	140	60	204	15	84	502	210	294	130	260	76	303	379	40	84	100/110	150	14/19	12
MAGNA1 D 40-100 F	220	53	140	60	204	15	84	502	210	294	130	260	76	303	379	40	84	100/110	150	14/19	12
MAGNA1 D 40-120 F	250	58	155	75	204	0	84	512	220	294	130	260	69	303	372	40	84	100/110	150	14/19	12
MAGNA1 D 40-150 F	250	58	155	75	204	0	84	512	220	294	130	260	69	303	372	40	84	100/110	150	14/19	12
MAGNA1 D 40-180 F	250	58	155	75	204	0	84	512	220	294	130	260	69	303	372	40	84	100/110	150	14/19	12
MAGNA1 D 50-40 F	240	48	160	45	204	45	84	515	221	294	130	260	75	304	379	50	102	110/125	165	14/19	12
MAGNA1 D 50-60 F	240	48	160	45	204	45	84	515	221	294	130	260	75	304	379	50	102	110/125	165	14/19	12
MAGNA1 D 50-80 F	240	48	160	45	204	45	84	515	221	294	130	260	75	304	379	50	102	110/125	165	14/19	12
MAGNA1 D 50-100 F	280	175	75	75	204	0	84	517	223	294	130	260	75	304	379	50	102	110/125	165	14/19	12
MAGNA1 D 50-120 F	280	175	75	75	204	0	84	517	223	294	130	260	75	304	379	50	102	110/125	165	14/19	12
MAGNA1 D 50-150 F	280	175	75	75	204	0	84	517	223	294	130	260	75	304	379	50	102	110/125	165	14/19	12
MAGNA1 D 50-180 F	280	175	75	75	204	0	84	517	223	294	130	260	75	304	379	50	102	110/125	165	14/19	12
MAGNA1 D 65-40 F	340	218	92	92	204	0	84	522	228	294	130	260	77	312	389	65	119	130/145	185	14/19	12
MAGNA1 D 65-60 F	340	218	92	92	204	0	84	522	228	294	130	260	77	312	389	65	119	130/145	185	14/19	12
MAGNA1 D 65-80 F	340	218	92	92	204	0	84	522	228	294	130	260	77	312	389	65	119	130/145	185	14/19	12
MAGNA1 D 65-100 F	340	218	92	92	204	0	84	522	228	294	130	260	77	312	389	65	119	130/145	185	14/19	12
MAGNA1 D 65-120 F	340	218	92	92	204	0	84	522	228	294	130	260	77	312	389	65	119	130/145	185	14/19	12
MAGNA1 D 65-150 F	340	218	92	92	204	0	84	522	228	294	130	260	77	312	389	65	119	130/145	185	14/19	12
MAGNA1 D 80-40 F	360	218	102	102	204	0	84	538	244	294	130	260	97	318	415	80	128	150/160	200	19	12
MAGNA1 D 80-60 F	360	218	102	102	204	0	84	538	244	294	130	260	97	318	415	80	128	150/160	200	19	12
MAGNA1 D 80-80 F	360	218	102	102	204	0	84	538	244	294	130	260	97	318	415	80	128	150/160	200	19	12
MAGNA1 D 80-100 F	360	218	102	102	204	0	84	538	244	294	130	260	97	318	415	80	128	150/160	200	19	12
MAGNA1 D 80-120 F	360	218	102	102	204	0	84	538	244	294	130	260	97	318	415	80	128	150/160	200	19	12
MAGNA1 D 100-40 F	450	243	147	147	204	0	84	551	252	299	135	270	103	330	434	100	160	170	220	19	12
MAGNA1 D 100-60 F	450	243	147	147	204	0	84	551	252	299	135	270	103	330	434	100	160	170	220	19	12
MAGNA1 D 100-80 F	450	243	147	147	204	0	84	551	252	299	135	270	103	330	434	100	160	170	220	19	12
MAGNA1 D 100-100 F	450	243	147	147	204	0	84	551	252	299	135	270	103	330	434	100	160	170	220	19	12
MAGNA1 D 100-120 F	450	243	147	147	204	0	84	551	252	299	135	270	103	330	434	100	160	170	220	19	12

Note

M3: Rp 1/4 for air vent available on all twin-head pumps.

3. Forces and moments

Maximum permissible forces and moments from the pipe connections acting on the pump flanges or threaded connections are indicated in fig 7.

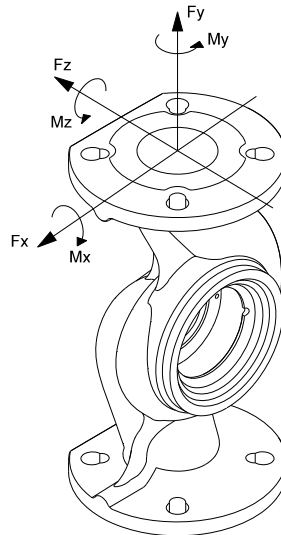

Fig. 7 Forces and moments from the pipe connections acting on the pump flanges or threaded connections

TM05 5639 4012

Diameter DN	Force [N]			Moment [Nm]				
	Fy	Fz	Fx	ΣF_b	My	Mz	Mx	ΣM_b
25*	350	425	375	650	300	350	450	650
32*	425	525	450	825	375	425	550	800
40	500	625	550	975	450	525	650	950
50	675	825	750	1300	500	575	700	1025
65	850	1050	925	1650	550	600	750	1100
80	1025	1250	1125	1975	575	650	800	1175
100	1350	1675	1500	2625	625	725	875	1300

* The values also apply to pumps with threaded connection.

The above values apply to cast-iron versions. For stainless-steel versions, the values can be multiplied by two according to the ISO 5199 standard.

4. Tightening torques for bolts

Recommended tightening torques for bolts used in flanged connections:

Bolt dimension	Torque
M12	27 Nm
M16	66 Nm

Argentina

Bombas GRUNDFOS de Argentina S.A.
Ruta Panamericana km. 37.500 Centro
Industrial Garin
1619 Garin Pcia. de B.A.
Phone: +54-3327 414 444
Telefax: +54-3327 45 3190

Australia

GRUNDFOS Pumps Pty. Ltd.
P.O. Box 2040
Regency Park
South Australia 5942
Phone: +61-8-8461-4611
Telefax: +61-8-8340 0155

Austria

GRUNDFOS Pumpen Vertrieb Ges.m.b.H.
Grundfosstraße 2
A-5082 Grödig/Salzburg
Tel.: +43-6246-883-0
Telefax: +43-6246-883-30

Belgium

N.V. GRUNDFOS Bellux S.A.
Boomssesteenweg 81-83
B-2630 Aartselaar
Tél.: +32-3-870 7300
Télécopie: +32-3-870 7301

Belarus

Представительство ГРУНДФОС в
Минске
220125, Минск
ул. Шафарнянская, 11, оф. 56, БЦ
«Порт»
Тел.: +7 (375 17) 286 39 72/73
Факс: +7 (375 17) 286 39 71
E-mail: minsk@grundfos.com

Bosnia and Herzegovina

GRUNDFOS Sarajevo
Zmaja od Bosne 7-7A,
BH-71000 Sarajevo
Phone: +387 33 592 480
Telefax: +387 33 590 465
www.ba.grundfos.com
e-mail: grundfos@bih.net.ba

Brazil

BOMBAS GRUNDFOS DO BRASIL
Av. Humberto de Alencar Castelo Branco,
630
CEP 09850 - 300
São Bernardo do Campo - SP
Phone: +55-11 4393 5533
Telefax: +55-11 4343 5015

Bulgaria

Grundfos Bulgaria EOOD
Slatina District
Iztochna Tangenta street no. 100
BG - 1592 Sofia
Tel. +359 2 49 22 200
Fax. +359 2 49 22 201
email: bulgaria@grundfos.bg

Canada

GRUNDFOS Canada Inc.
2941 Brighton Road
Oakville, Ontario
L6H 6C9
Phone: +1-905 829 9533
Telefax: +1-905 829 9512

China

GRUNDFOS Pumps (Shanghai) Co. Ltd.
10F The Hub, No. 33 Suhong Road
Minhang District
Shanghai 201106
PRC
Phone: +86 21 612 252 22
Telefax: +86 21 612 253 33

COLOMBIA

GRUNDFOS Colombia S.A.S.
Km 1.5 vía Siberia-Cota Conj. Potrero
Chico,
Parque Empresarial Arcos de Cota Bod.
1A.
Cota, Cundinamarca
Phone: +57(1)-2913444
Telefax: +57(1)-8764586

Croatia

GRUNDFOS CROATIA d.o.o.
Buzinski prilaz 38, Buzin
HR-10010 Zagreb
Phone: +385 1 6595 400
Telefax: +385 1 6595 499
www.hr.grundfos.com

GRUNDFOS Sales Czechia and**Slovakia s.r.o.**

Čajkovského 21
779 00 Olomouc
Phone: +420-585-716 111

Denmark

GRUNDFOS DK A/S
Martin Bachs Vej 3
DK-8850 Bjerringbro
Tlf.: +45-87 50 50 50
Telefax: +45-87 50 51 51
E-mail: info_GDK@grundfos.com
www.grundfos.com/DK

Estonia

GRUNDFOS Pumps Eesti OÜ
Peterburi tee 92G
11415 Tallinn
Tel: + 372 606 1690
Fax: + 372 606 1691

Finland

OY GRUNDFOS Pumpat AB
Trukkikuja 1
FI-01360 Vantaa
Phone: +358-(0) 207 889 500

France

Pompes GRUNDFOS Distribution S.A.
Parc d'Activités de Chesnes
57, rue de Malacombe
F-38290 St. Quentin Fallavier (Lyon)
Tél.: +33-4 74 82 15 15
Télécopie: +33-4 74 94 10 51

Germany

GRUNDFOS GMBH
Schlüterstr. 33
40699 Erkrath
Tel.: +49-(0) 211 929 69-0
Telefax: +49-(0) 211 929 69-3799
e-mail: infoservice@grundfos.de
Service in Deutschland:
e-mail: kundendienst@grundfos.de

Greece

GRUNDFOS Hellas A.E.B.E.
20th km. Athinon-Markopoulou Av.
P.O. Box 71
GR-19002 Peania
Phone: +0030-210-66 83 400
Telefax: +0030-210-66 46 273

Hong Kong

GRUNDFOS Pumps (Hong Kong) Ltd.
Unit 1, Ground floor
Siu Wai Industrial Centre
29-33 Wing Hong Street &
68 King Lam Street, Cheung Sha Wan
Kowloon
Phone: +852-27861706 / 27861741
Telefax: +852-27858664

Hungary

GRUNDFOS Hungária Kft.
Park u. 8
H-2045 Törökbálint,
Phone: +36-23 511 110
Telefax: +36-23 511 111

India

GRUNDFOS Pumps India Private Limited
118 Old Mahabalipuram Road
Thoraiakkam
Chennai 600 096
Phone: +91-44 2496 6800

Indonesia

PT. GRUNDFOS POMPA
Graha Intirub Lt. 2 & 3
Jln. Cililitan Besar No.454. Makasar,
Jakarta Timur
ID-Jakarta 13650
Phone: +62 21-469-51900
Telefax: +62 21-460 6910 / 460 6901

Ireland

GRUNDFOS (Ireland) Ltd.
Unit A, Merrywell Business Park
Ballymount Road Lower
Dublin 12
Phone: +353-1-4089 800
Telefax: +353-1-4089 830

Italy

GRUNDFOS Pompe Italia S.r.l.
Via Gran Sasso 4
I-20060 Truccazzano (Milano)
Tel.: +39-02-95838112
Telefax: +39-02-95309290 / 95838461

Japan

GRUNDFOS Pumps K.K.
1-2-3, Shin-Miyakoda, Kita-ku,
Hamamatsu
431-2103 Japan
Phone: +81 53 428 4760
Telefax: +81 53 428 5005

Korea

GRUNDFOS Pumps Korea Ltd.
6th Floor, Aju Building 679-5
Yeoksam-dong, Kangnam-ku, 135-916
Seoul, Korea
Phone: +82-2-5317 600
Telefax: +82-2-5633 725

Latvia

SIA GRUNDFOS Pumps Latvia
Deglava biznesa centrs
Augusta Deglava ielā 60, LV-1035, Rīga,
Tālr.: + 371 714 9640, 7 149 641
Fakss: + 371 914 9646

Lithuania

GRUNDFOS Pumps UAB
Smolensko g. 6
LT-03201 Vilnius
Tel: + 370 52 395 430
Fax: + 370 52 395 431

Malaysia

GRUNDFOS Pumps Sdn. Bhd.
7 Jalan Peguam U1/25
Glenmarie Industrial Park
40150 Shah Alam
Selangor
Phone: +60-3-5569 2922
Telefax: +60-3-5569 2866

Mexico

Bombas GRUNDFOS de México S.A. de
C.V.
Boulevard TLC No. 15
Parque Industrial Stiva Aeropuerto
Apodaca, N.L. 66600
Phone: +52-81-8144 4000
Telefax: +52-81-8144 4010

Netherlands

GRUNDFOS Netherlands
Veluwezoom 35
1326 AE Almere
Postbus 22015
1302 CA ALMERE
Tel.: +31-88-478 6336
Telefax: +31-88-478 6332
E-mail: info_gnl@grundfos.com

New Zealand

GRUNDFOS Pumps NZ Ltd.
17 Beatrice Tinsley Crescent
North Harbour Industrial Estate
Albany, Auckland
Phone: +64-9-415 3240
Telefax: +64-9-415 3250

Norway

GRUNDFOS Pumper A/S
Strømsveien 344
Postboks 235, Leirdal
N-1011 Oslo
Tlf.: +47-22 90 47 00
Telefax: +47-22 32 21 50

Poland

GRUNDFOS Pompy Sp. z o.o.
ul. Klonowa 23
Baranowo k. Poznania
PL-62-081 Przeźmierowo
Tel: (+48-61) 650 13 00
Fax: (+48-61) 650 13 50

Portugal

Bombas GRUNDFOS Portugal, S.A.
Rua Calvet de Magalhães, 241
Apartado 1079
P-2770-153 Paço de Arcos
Tel.: +351-21-440 76 00
Telefax: +351-21-440 76 90

Romania

GRUNDFOS Pompe România SRL
Bd. Biruintei, nr 103
Pantelimon county Ilfov
Phone: +40 21 200 4100
Telefax: +40 21 200 4101
E-mail: romania@grundfos.ro

Russia

ООО Грундфос Россия
109544, г. Москва, ул. Школьная, 39-41,
стр. 1
Тел. (+7) 495 564-88-00 (495) 737-30-00
Факс (+7) 495 564 88 11
E-mail grundfos.moscow@grundfos.com

Serbia

Grundfos Srbija d.o.o.
Omladinskih brigada 90b
11070 Novi Beograd
Phone: +381 11 2258 740
Telefax: +381 11 2281 769
www.rs.grundfos.com

Singapore

GRUNDFOS (Singapore) Pte. Ltd.
25 Jalan Tukang
Singapore 619264
Phone: +65-6681 9688
Telefax: +65-6681 9689

Slovakia

GRUNDFOS s.r.o.
Prievozská 4D
821 09 BRATISLAVA
Phona: +421 2 5020 1426
sk.grundfos.com

Slovenia

GRUNDFOS LJUBLJANA, d.o.o.
Leskoškova 9e, 1122 Ljubljana
Phone: +386 (0) 1 568 06 10
Telefax: +386 (0)1 568 06 19
E-mail: tehnika-si@grundfos.com

South Africa

GRUNDFOS (PTY) LTD
Corner Mountjoy and George Allen Roads
Wilbart Ext. 2
Bedfordview 2008
Phone: (+27) 11 579 4800
Fax: (+27) 11 455 6066
E-mail: lsmart@grundfos.com

Spain

Bombas GRUNDFOS España S.A.
Camino de la Fuentequilla, s/n
E-28110 Algete (Madrid)
Tel.: +34-91-848 8800
Telefax: +34-91-628 0465

Sweden

GRUNDFOS AB
Box 333 (Lunnagårdsgatan 6)
431 24 Mölndal
Tel.: +46 31 332 23 000
Telefax: +46 31 331 94 60

Switzerland

GRUNDFOS Pumpen AG
Bruggacherstrasse 10
CH-8117 Fällanden/ZH
Tel.: +41-44-806 8111
Telefax: +41-44-806 8115

Taiwan

GRUNDFOS Pumps (Taiwan) Ltd.
7 Floor, 219 Min-Chuan Road
Taichung, Taiwan, R.O.C.
Phone: +886-4-2305 0868
Telefax: +886-4-2305 0878

Thailand

GRUNDFOS (Thailand) Ltd.
92 Chaloen Phrakiat Rama 9 Road,
Dokmai, Pravej, Bangkok 10250
Phone: +66-2-725 8999
Telefax: +66-2-725 8998

Turkey

GRUNDFOS POMPA San. ve Tic. Ltd. Sti.
Gebze Organize Sanayi Bölgesi
İhsan dede Caddesi,
2. yol 200. Sokak No. 204
41490 Gebze/ Kocaeli
Phone: +90 - 262-679 7979
Telefax: +90 - 262-679 7905
E-mail: satis@grundfos.com

Ukraine

Бізнес Центр Європа
Столичне шосе, 103
м. Київ, 03131, Україна
Телефон: (+38 044) 237 04 00
Факс.: (+38 044) 237 04 01
E-mail: ukraine@grundfos.com

United Arab Emirates

GRUNDFOS Gulf Distribution
P.O. Box 16768
Jebel Ali Free Zone
Dubai
Phone: +971 4 8815 166
Telefax: +971 4 8815 136

United Kingdom

GRUNDFOS Pumps Ltd.
Grovebury Road
Leighton Buzzard/Beds. LU7 4TL
Phone: +44-1525-850000
Telefax: +44-1525-850011

U.S.A.

GRUNDFOS Pumps Corporation
17100 West 118th Terrace
Olathe, Kansas 66061
Phone: +1-913-227-3400
Telefax: +1-913-227-3500

Uzbekistan

Grundfos Tashkent, Uzbekistan The Repre-
sentative Office of Grundfos Kazakhstan in
Uzbekistan
38a, Oybek street, Tashkent
Телефон: (+998) 71 150 3290 / 71 150
3291
Факс: (+998) 71 150 3292

Addresses Revised 05.12.2016

98091804 1116

ECM: 1197356
