

Conlift1, Conlift2 and Conlift2 pH+

Installation and operating instructions



Other languages



Conlift1, Conlift2 and Conlift2 pH+
<http://net.grundfos.com/qr/i/97936207>

be
think
innovate

GRUNDFOS 

English (GB) Installation and operating instructions

Original installation and operating instructions

These installation and operating instructions describe Grundfos Conlift.

Sections 1-4 give the information necessary to be able to unpack, install and start up the product in a safe way.

Sections 5-10 give important information about the product, as well as information on service, fault finding and disposal of the product.

CONTENTS

	Page
1. Symbols used in this document	2
1.1 Warnings against hazards involving risk of death or personal injury	2
1.2 Other important notes	2
2. Receiving the product	3
2.1 Transporting the product	3
3. Installing the product	3
3.1 Mechanical installation	3
3.2 Electrical connection	3
4. Starting up the product	4
4.1 Checking the function	4
5. Product introduction	5
5.1 Product description	5
5.2 Intended use	5
5.3 Operating mode	5
5.4 Handling of condensates	5
5.5 Marking and approvals	5
5.6 Accessories	6
6. Control functions	6
7. Servicing the product	6
7.1 Maintenance	6
7.2 Service	6
7.3 Contaminated products	7
8. Fault finding the product	8
9. Technical data	9
10. Disposal	9



Read this document before installing the product. Installation and operation must comply with local regulations and accepted codes of good practice.



This appliance can be used by children aged from 8 years and above and persons with reduced physical, sensory or mental capabilities or lack of experience and knowledge if they have been given supervision or instruction concerning use of the appliance in a safe way and understand the hazards involved.

Children shall not play with the appliance. Cleaning and user maintenance shall not be made by children without supervision.

1. Symbols used in this document

1.1 Warnings against hazards involving risk of death or personal injury



DANGER

Indicates a hazardous situation which, if not avoided, will result in death or serious personal injury.



WARNING

Indicates a hazardous situation which, if not avoided, could result in death or serious personal injury.



CAUTION

Indicates a hazardous situation which, if not avoided, could result in minor or moderate personal injury.

The text accompanying the three hazard symbols DANGER, WARNING and CAUTION is structured in the following way:



SIGNAL WORD

Description of hazard

Consequence of ignoring the warning.
- Action to avoid the hazard.

1.2 Other important notes



A blue or grey circle with a white graphical symbol indicates that an action must be taken.



A red or grey circle with a diagonal bar, possibly with a black graphical symbol, indicates that an action must not be taken or must be stopped.



If these instructions are not observed, it may result in malfunction or damage to the equipment.



Tips and advice that make the work easier.

2. Receiving the product

2.1 Transporting the product

WARNING



Harm of body

- Death or serious personal injury
- Stack maximum two pallets together under transportation.

3. Installing the product



Installation must be carried out by specially trained persons and according to local regulations.

If not already integrated, a water trap (emission trap) must be fitted in all inlets.

Conflit is not designed for outdoor use.

3.1 Mechanical installation

See also the quick guide supplied with Conflit.

When installing Conflit, observe the following:

- The condensate must run freely into the lifting station.
- The cooling slots in the motor cover must not be covered.
- The lifting station should be easily accessible in order to facilitate maintenance.
- The lifting station must be installed in a well-illuminated and -ventilated room.
- The lifting station is protected against splashing water (in compliance with IP24).

3.1.1 Alarm PCB

The accessory Alarm PCB incorporates a printed-circuit board (PCB) enabling additional functions when the level in the tank reaches the alarm level.

The contact on the PCB can be set to two positions:

Position 1: The pump is started, and an acoustic alarm is generated.

A: The alarm cable is not connected to the condensate source or an external alarm. The condensate source is not switched off.

B: The alarm cable is connected to the condensate source or an external alarm. The condensate source is switched off. See section [3.2.1 Cable to condensate source or external alarm](#).

Position 2: The pump does not start, and an acoustic alarm is generated.

A: The alarm cable is not connected to the condensate source or an external alarm. The condensate source is not switched off.

B: The alarm cable is connected to the condensate source or an external alarm. The condensate source is switched off. See section [3.2.1 Cable to condensate source or external alarm](#).

3.2 Electrical connection

DANGER

Electric shock

- Death or serious personal injury
- The protective earth (PE) of the power outlet must be connected to the protective earth of the product. The plug must have the same PE connection system as the power outlet.



DANGER

Electric shock

- Death or serious personal injury
- The installation must be fitted with a residual current device (RCD) with a tripping current less than 30 mA.



DANGER

Electric shock

- Death or serious personal injury
- The product must be connected to an external main switch with a minimum contact gap of 3 mm (0.12 inch) in all poles.



Electrical connection must be carried out by an authorized electrician.

Check that the supply voltage and frequency correspond to the values stated on the nameplate.

The power supply cable has a Schuko plug or a free cable end. The cable has a length of 2 metres.

3.2.1 Cable to condensate source or external alarm



The electrical connection of a cable with a free cable end must be carried out by an authorised electrician.

Conlift has a safety overflow switch which can be connected to the condensate source or to an external alarm system. The switch is connected to a 1.7 metre alarm cable with free cable end.

Alarm systems with a control voltage of 250 VAC, 2.5 A, can be used.

On delivery, the alarm cable is connected to terminals COM1 (brown) and NC2 (blue) of the safety overflow switch. See fig. 1.

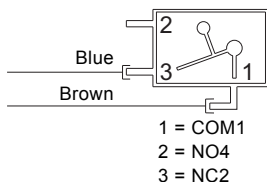

Fig. 1 Wiring diagram

The alarm cable can be connected in two ways, depending on application:

- **Shutdown of condensate source**
The safety overflow switch can be connected to a Class-II low-voltage circuit. To enable shutdown of the condensate source, the COM1 and NC2 terminals of the safety overflow switch must be connected in series with the low-voltage thermostat circuit of the condensate source.
- **External alarm system**
The COM1 and NO4 terminals can be used to close a low-voltage alarm circuit. To activate an alarm, the COM1 and NO4 terminals of the safety overflow switch must be connected in series with the low-voltage alarm circuit.

4. Starting up the product



Start up Conlift in accordance with local regulations and accepted codes of good practice.

1. Check that all hoses and connections are tight.
2. Connect the power supply.

4.1 Checking the function

Pump operation

Press the manual test button.

Alarm

1. To ensure that the alarm level is reached, squeeze the outlet hose or close the isolating valve, if fitted, and fill water into the tank. The pump will be started via the float switch.
2. Continue filling water into the tank until the safety overflow switch is activated. If no external alarm is connected to Conlift, this function can be checked by means of a multimeter.



The safety overflow switch must be activated before the water starts running out of Conlift.

3. Stop filling water into the tank and stop squeezing the outlet hose. The alarm stops (the switch opens). The pump continues operating. When the stop level is reached, the pump stops.

After checking the function, push the inlet hose back into the lifting station and let the condensate from the boiler or air-conditioning system run into the tank again.

TM05 1152 2211

5. Product introduction

5.1 Product description

Grundfos Conlift1 is a small, compact lifting station with a built-in non-return valve.

The lifting station incorporates a printed-circuit board (PCB) with a safety device enabling an alarm function and additional pump start in case of overflow.

The pH+ Box is a neutralisation unit designed to neutralise the acid condensate coming from gas- and oil-powered boilers and is available as accessory. See section 9. [Technical data](#).

5.2 Intended use

Conlift is designed for the pumping of condensate from the following:

- boilers
- air-conditioning systems
- cooling and refrigeration systems
- air dehumidifiers
- evaporators.

Conlift is suitable for the pumping of condensate which is collected below sewer level or which cannot flow to the sewage system or drain of the building by means of a natural downward slope.

WARNING



Biological hazard

- Death or serious personal injury
- Use the product only to pump condensates.

Conlift can pump condensates not requiring neutralisation, i.e. with pH values of 2.5 or higher.

Condensates with pH values up to 2.5 should be neutralised before they leave Conlift.

Boilers fired with the following fuels normally supply condensate with pH values up to 2.5:

- gas
- liquid gas
- low-sulphur fuel oil according to DIN 51603-1.

Irrespective of the capability of Conlift, local regulations may require the installation of a neutralisation unit, even for pH values of 2.5 or higher.

5.3 Operating mode

Conlift is designed for maximum 60 starts per hour. S3 (intermittent operation): 30 % according to DIN EN 0530 T1. This means that the system is running for 18 seconds and is stopped for 42 seconds.

5.4 Handling of condensates



If Conlift is to be connected to a pressure-reducing valve, observe the boiler manufacturer's instructions.



When cleaning heat exchangers and burner units of boiler systems, make sure that no acid and cleaning residuals enter the condensing unit.

Condensates from condensate boilers are very aggressive and will attack the material of the building's sewage system.

In order to protect the sewage system, we recommend that

you use the neutralisation unit pH+ Box. See section 9. [Technical data](#).

The local outlet regulations regarding condensates from boilers must be met.

5.5 Marking and approvals

Marking



Approvals



5.6 Accessories

The following accessories for Conlift are available from your local Grundfos supplier.

Accessory/ service part	Description	Product number
pH+ Box	Complete neutralisation unit including fitting accessories, neutralisation granulate and pH indicator.	97936176
Extension hose	6 metres of PVC hose with 10 mm internal diameter including one hose coupling.	97936177
Granulate refill package	Granulate, 4 x 1.4 kg.	97936178
Alarm PCB Conlift	Printed-circuit board (PCB) enabling additional pump start at alarm level or stop of boiler with acoustic alarm.	97936209

6. Control functions

The condensate runs by natural fall through a hose into the tank. See section [7. Servicing the product](#).

The liquid level in the tank is controlled automatically by a float switch. A micro switch in the float switch will start the pump when the liquid level reaches the start level, and it will stop the pump again when the liquid level has fallen to the stop level. The condensate is pumped through the outlet hose to the drain.

Conlift also has a safety overflow switch. This overflow switch can be connected to the condensate boiler and set to stop the boiler in case of an alarm.

Conlift has a thermal switch which stops the motor in case of overload. When the motor has cooled to normal temperature, it restarts automatically.

7. Servicing the product

Always use original accessories from Grundfos to ensure safe and reliable operation.

WARNING

Electric shock



Death or serious personal injury
- Before starting any work on the product, make sure that the power supply has been switched off and that it cannot be accidentally switched on.



Maintenance and service must be carried out by specially trained persons and according to local regulations.



If the power supply cable is damaged, it must be replaced by the manufacturer, the manufacturer's service partner or similarly qualified person.

7.1 Maintenance

Conlift does not require any special maintenance, but we recommend that you check operation and pipe connections at least once a year and that you clean the collecting tank, if necessary.

pH + Box

Check the state of the granulate regularly.

Check the level of acid in the condensate with the supplied pH indicator twice a year.

See section [7.2 Service](#).

7.2 Service

Thanks to the Conlift design, service can easily be performed in case of malfunction or blocked pump.



Electrical connection must be carried out by an authorized electrician.

WARNING

Electric shock



Death or serious personal injury
- Before starting any work on the product, make sure that the power supply has been switched off and that it cannot be accidentally switched on.

7.2.1 Conlift1 and Alarm PCB

See illustrations on page 10.

Make the following checks and clean the collecting tank, if necessary:

1. Disconnect the power supply.
2. Cut off the flow of condensate from the boiler or other application, or stop the flow of condensate to Conlift.
3. Make sure that the hoses are not mechanically or chemically damaged.
4. Remove the outlet hose by turning the bayonet coupling, and check the O-ring. The condensate in the hose will not run out due to the non-return valve.
5. If the condensate is running out of the hose, check and clean the non-return valve.
6. Press the side-locking catches and lift off the motor support. Place it in upright position.
7. Remove deposits, dirt, algae and incrustations under running water.

7.2.2 pH + Box

Neutralisation unit

See illustrations on page 11.

Check and clean the neutralisation unit drawer regularly.

Make the following checks, measure the pH level and clean the collecting tank, if necessary.

1. Disconnect the power supply.
2. Cut off the flow of condensate from the boiler or other application, or stop the flow of condensate to Conlift.
3. Check the pH value of the granulate in the drawer with the supplied pH indicator.
4. If the drawer is empty or the pH indicator indicates an acid level below 5, fill the drawer with neutralisation granulate (approx. 1.5 kg).
5. Make sure that the hoses are not mechanically or chemically damaged.
6. Remove the outlet hose by turning the bayonet coupling, and check the O-ring. The condensate in the hose will not run out due to the non-return valve.
7. If the condensate is running out of the hose, check and clean the non-return valve.
8. Press the side-locking catch and lift off the neutralisation unit.
9. Press the side-locking catches and lift off the motor support. Place it in upright position.
10. Remove deposits, dirt, algae and incrustations under running water.

7.3 Contaminated products

If a Conlift has been used for a liquid which is injurious to health or toxic, it will be classified as contaminated.

CAUTION

Biological hazard



- Minor or moderate personal injury
- Flush the product thoroughly with clean water and rinse the parts in water after dismantling.

The product will be classified as contaminated if it has been used for a liquid which is injurious to health or toxic.

If you request Grundfos to service the product, contact Grundfos with details about the liquid before returning the product for service. Otherwise, Grundfos can refuse to accept the product for service.

Any application for service must include details about the liquid.

Clean the product in the best possible way before you return it.

Costs of returning the product are to be paid by the customer.

8. Fault finding the product

WARNING

Electric shock

- Death or serious personal injury
- Before starting any work on the product, make sure that the power supply has been switched off and that it cannot be accidentally switched on.



Fault	Cause	Remedy
1. The pump does not run.	a) No power supply.	Connect the power supply.
	b) A fuse is blown.	Replace the fuse (1 A slow-blow fuse).
	c) The power supply cable is damaged.	Repair or replace the cable. This must only be carried out by an authorised service workshop or by Grundfos.
	d) The thermal overload switch has tripped: <ul style="list-style-type: none"> - The motor is not sufficiently cooled. - Deposits in the pump. 	Clean the cooling slots in the motor cover. <hr/> Clean the impeller, pump housing and the entire lifting station.
2. Reduced or no performance.	a) Outlet hose squeezed or broken.	Straighten the outlet hose or replace it. The bending radius of the hose should be at least 60 mm.
	b) The non-return valve does not open.	Remove the outlet connection, and clean the non-return valve.
	c) The motor fan cannot be turned freely.	Clean the pump housing and the impeller.
3. Frequent starts/stops.	a) The non-return valve does not close.	Remove the outlet connection, and clean the non-return valve.
	b) The inlet quantity is too high.	Make sure the inlet quantity is correct.
4. Alarm.	a) The condensate is not pumped out of the tank.	See points 1 and 2.

9. Technical data

Supply voltage

1 x 230 VAC - 6 %/+ 6 %, 50 Hz, PE.

See the nameplate.

Input power

P1 = 70 W.

Input current

I = 0.65 A.

Alarm connection

An external alarm can be connected via the safety overflow switch.

The cable can stand a control voltage of 250 VAC, 2.5 A.

Cable lengths

Power supply cable: 2.0 metres.

Alarm cable: 1.7 metres.

Storage temperature

When stored in dry rooms:

- Empty tank: -10 °C to +50 °C.
- Tank with condensate: above 0 °C (risk of frost not allowed).

Ambient temperature

During operation: +5 °C to +35 °C.

Liquid temperature

Average temperature: +50 °C.

Maximum head

5.5 metres.

Maximum flow rate

600 l/h.

pH value of condensate

2.5 or higher.

Density of condensate

Maximum 1000 kg/m³.

Motor protection

- Thermal overload switch: +120 °C.
- Insulation class: F.

Enclosure class

IP24.

Weight

2.0 kg.

Volume

- Tank volume: 2.65 litres.
- Useful volume: 0.9 litre.
- Alarm condition: 2.1 litres.
- Operating condition: 1.7 litres.

Dimensions

See dimensional sketches on pages [13](#) to [14](#).

10. Disposal

This product or parts of it must be disposed of in an environmentally sound way:

1. Use the public or private waste collection service.
2. If this is not possible, contact the nearest Grundfos company or service workshop.



The crossed-out wheellie bin symbol on a product means that it must be disposed of separately from household waste. When a product marked with this symbol reaches its end of life, take it to a collection point designated by the local waste disposal authorities. The separate collection and recycling of such products will help protect the environment and human health.

Appendix

Conlift1 and Conlift2

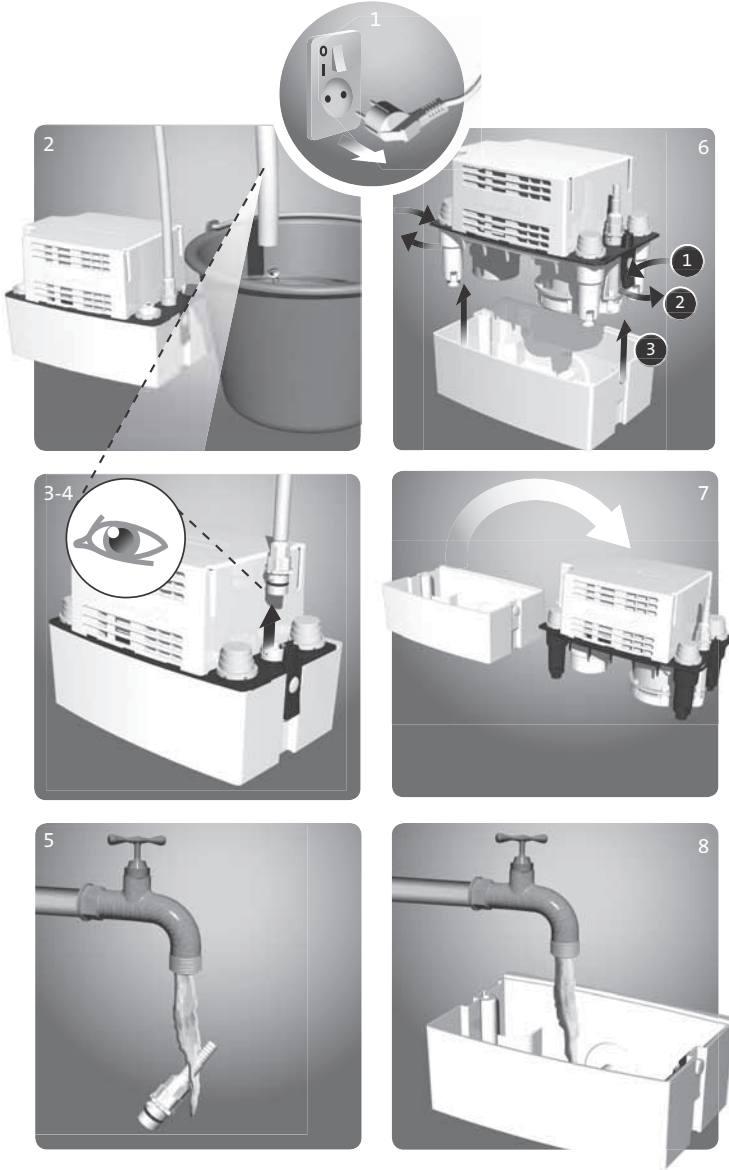

TM05 1224 2411

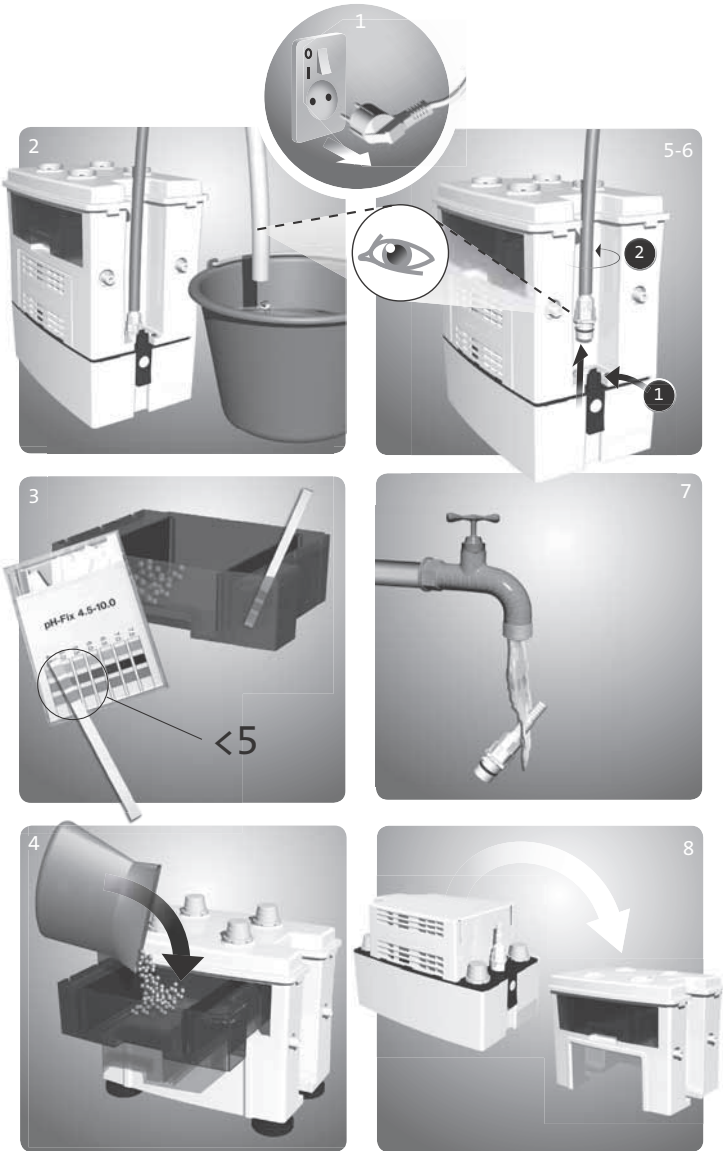

TM05 1225 2411

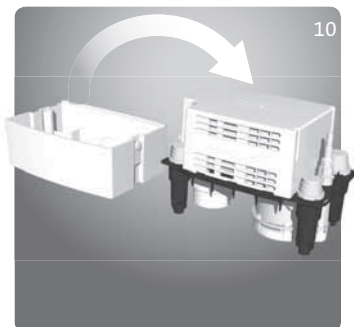
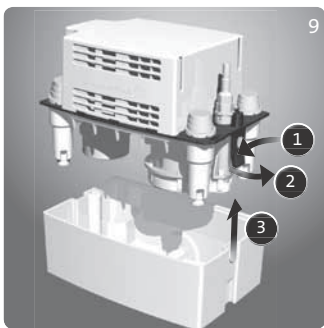

TM05 1226 2411

Dimensions, Conlift1 and Conlift2

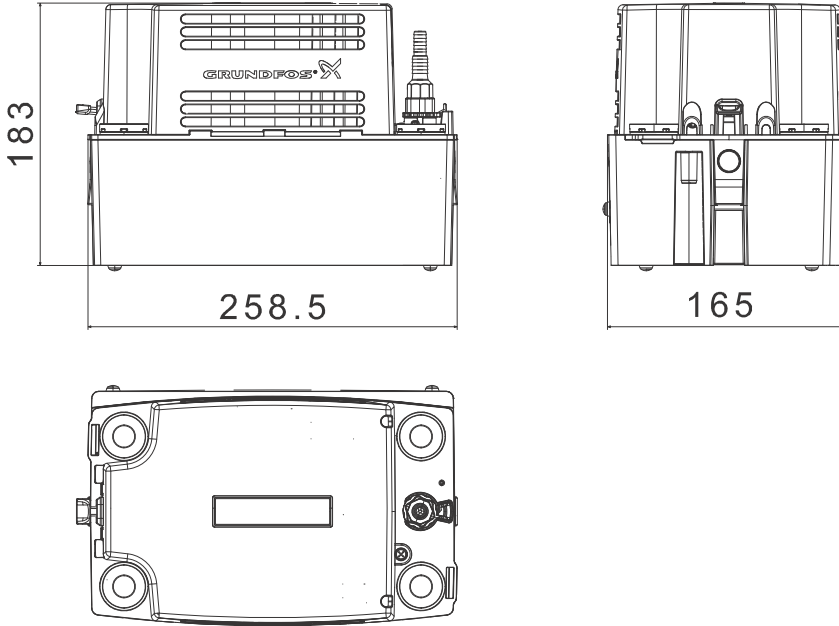

Dimensions, Conlift pH+ Box

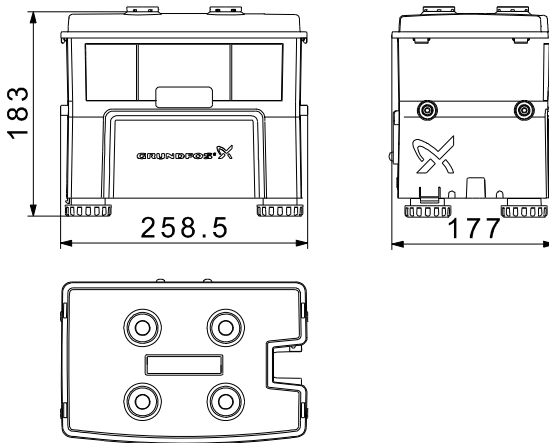

TM05 1227 2411

TM05 1228 2411

Dimensions, pH+ Box

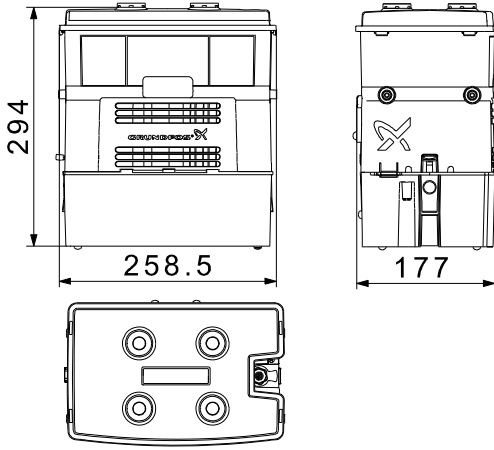

TN05 1229 2411

Argentina

Bombas GRUNDFOS de Argentina S.A.
Ruta Panamericana km. 37.500 Centro
Industrial Garin
1619 Garin Pcia. de B.A.
Phone: +54-3327 414 444
Telefax: +54-3327 45 3190

Australia

GRUNDFOS Pumps Pty. Ltd.
P.O. Box 2040
Regency Park
South Australia 5942
Phone: +61-8-8461-4611
Telefax: +61-8-8340 0155

Austria

GRUNDFOS Pumpen Vertrieb
Ges.m.b.H.
Grundfosstraße 2
A-5082 Grödig/Salzburg
Tel.: +43-6246-883-0
Telefax: +43-6246-883-30

Belgium

N.V. GRUNDFOS Bellux S.A.
Boomsesteenweg 81-83
B-2630 Aartselaar
Tél.: +32-3-870 7300
Télécopie: +32-3-870 7301

Belarus

Представительство ГРУНДФОС в
Минске
220125, Минск
ул. Шафарнянская, 11, оф. 56, БЦ
«Порт»
Тел.: +7 (375 17) 286 39 72/73
Факс: +7 (375 17) 286 39 71
E-mail: minsk@grundfos.com

Bosnia and Herzegovina

GRUNDFOS Sarajevo
Zmaj od Bosne 7-7A,
BH-71000 Sarajevo
Phone: +387 33 592 480
Telefax: +387 33 590 465
www.ba.grundfos.com
e-mail: grundfos@bih.net.ba

Brazil

BOMBAS GRUNDFOS DO BRASIL
Av. Humberto de Alencar Castelo
Branco, 630
CEP 09850 - 300
São Bernardo do Campo - SP
Phone: +55-11 4393 5533
Telefax: +55-11 4343 5015

Bulgaria

Grundfos Bulgaria EOOD
Slatina District
Iztochna Tangenta street no. 100
BG - 1592 Sofia
Tel. +359 2 49 22 200
Fax. +359 2 49 22 201
email: bulgaria@grundfos.bg

Canada

GRUNDFOS Canada Inc.
2941 Brighton Road
Oakville, Ontario
L6H 6C9
Phone: +1-905 829 9533
Telefax: +1-905 829 9512

China

GRUNDFOS Pumps (Shanghai) Co. Ltd.
10F The Hub, No. 33 Suhong Road
Minhang District
Shanghai 201106
PRC
Phone: +86 21 612 252 22
Telefax: +86 21 612 253 33

COLOMBIA

GRUNDFOS Colombia S.A.S.
Km 1.5 vía Siberia-Cota Conj. Potrero
Chico,
Parque Empresarial Arcos de Cota Bod.
1A.
Cota, Cundinamarca
Phone: +57(1)-2913444
Telefax: +57(1)-8764586

Croatia

GRUNDFOS CROATIA d.o.o.
Buzinski prilaz 38, Buzin
HR-10010 Zagreb
Phone: +385 1 6595 400
Telefax: +385 1 6595 499
www.hr.grundfos.com

GRUNDFOS Sales Czechia and Slovakia s.r.o.

Čajkovského 21
779 00 Olomouc
Phone: +420-585-716 111

Denmark

GRUNDFOS DK A/S
Martin Bachs Vej 3
DK-8850 Bjerringbro
Tlf.: +45-87 50 50 50
Telefax: +45-87 50 51 51
E-mail: info_GDK@grundfos.com
www.grundfos.com/DK

Estonia

GRUNDFOS Pumps Eesti OÜ
Peterburi tee 92G
11415 Tallinn
Tel: + 372 606 1690
Fax: + 372 606 1691

Finland

OY GRUNDFOS Pumput AB
Trukkikuja 1
FI-01360 Vantaa
Phone: +358-(0) 207 889 500

France

Pompes GRUNDFOS Distribution S.A.
Parc d'Activités de Chesnes
57, rue de Malacombe
F-38290 St. Quentin Fallavier (Lyon)
Tél.: +33-4 74 82 15 15
Télécopie: +33-4 74 94 10 51

Germany

GRUNDFOS GMBH
Schlüterstr. 33
40699 Erkrath
Tel.: +49-(0) 211 929 69-0
Telefax: +49-(0) 211 929 69-3799
e-mail: infoservice@grundfos.de
Service in Deutschland:
e-mail: kundendienst@grundfos.de

Greece

GRUNDFOS Hellas A.E.B.E.
20th km. Athinon-Markopoulou Av.
P.O. Box 71
GR-19002 Peania
Phone: +0030-210-66 83 400
Telefax: +0030-210-66 46 273

Hong Kong

GRUNDFOS Pumps (Hong Kong) Ltd.
Unit 1, Ground floor
Siu Wai Industrial Centre
29-33 Wing Hong Street &
68 King Lam Street, Cheung Sha Wan
Kowloon
Phone: +852-27861706 / 27861741
Telefax: +852-27858664

Hungary

GRUNDFOS Hungária Kft.
Tópark u. 8
H-2045 Törökbálint,
Phone: +36-23 511 110
Telefax: +36-23 511 111

India

GRUNDFOS Pumps India Private
Limited
118 Old Mahabalipuram Road
Thoraiakkam
Chennai 600 096
Phone: +91-44 2496 6800

Indonesia

PT. GRUNDFOS POMPA
Graha Intirub Lt. 2 & 3
Jln. Cililitan Besar No.454. Makasar,
Jakarta Timur
ID-Jakarta 13650
Phone: +62 21-469-51900
Telefax: +62 21-460 6910 / 460 6901

Ireland

GRUNDFOS (Ireland) Ltd.
Unit A, Merrywell Business Park
Ballymount Road Lower
Dublin 12
Phone: +353-1-4089 800
Telefax: +353-1-4089 830

Italy

GRUNDFOS Pompe Italia S.r.l.
Via Gran Sasso 4
I-20060 Truccazzano (Milano)
Tel.: +39-02-95838112
Telefax: +39-02-95309290 / 95838461

Japan

GRUNDFOS Pumps K.K.
1-2-3, Shin-Miyakoda, Kita-ku,
Hamamatsu
431-2103 Japan
Phone: +81 53 428 4760
Telefax: +81 53 428 5005

Korea

GRUNDFOS Pumps Korea Ltd.
679 Floor, Aju Building 679-5
Yeoksam-dong, Kangnam-ku, 135-916
Seoul, Korea
Phone: +82-2-5317 600
Telefax: +82-2-5633 725

Latvia

SIA GRUNDFOS Pumps Latvia
Deglava biznesa centrs
Augusta Deglava iela 60, LV-1035, Rīga,
Tālr.: + 371 714 9640, 7 149 641
Faks: + 371 914 9646

Lithuania

GRUNDFOS Pumps UAB
Smolensko g. 6
LT-03201 Vilnius
Tel: + 370 52 395 430
Fax: + 370 52 395 431

Malaysia

GRUNDFOS Pumps Sdn. Bhd.
7 Jalan Peguam U1/25
Glenmarie Industrial Park
40150 Shah Alam
Selangor
Phone: +60-3-5569 2922
Telefax: +60-3-5569 2866

Mexico

Bombas GRUNDFOS de México S.A. de
C.V.
Boulevard TLC No. 15
Parque Industrial Stiva Aeropuerto
Apodaca, N.L. 66600
Phone: +52-81-8144 4000
Telefax: +52-81-8144 4010

Netherlands

GRUNDFOS Netherlands
Veluwezoom 35
1326 AE Almere
Postbus 22015
1302 CA ALMERE
Tel.: +31-88-478 6336
Telefax: +31-88-478 6332
E-mail: info_gnl@grundfos.com

New Zealand

GRUNDFOS Pumps NZ Ltd.
17 Beatrice Tinsley Crescent
North Harbour Industrial Estate
Auckland
Phone: +64-9-415 3240
Telefax: +64-9-415 3250

Norway

GRUNDFOS Pumper A/S
Strømsveien 344
Postboks 235, Leirdal
N-1011 Oslo
Tlf.: +47-22 90 47 00
Telefax: +47-22 32 21 50

Poland

GRUNDFOS Pompy Sp. z o.o.
ul. Klonowa 23
Baranowo k. Poznania
PL-62-081 Przeźmierowo
Tel: (+48-61) 650 13 00
Fax: (+48-61) 650 13 50

Portugal

Bombas GRUNDFOS Portugal, S.A.
Rua Calvet de Magalhães, 241
Apartado 1079
P-2770-153 Paço de Arcos
Tel.: +351-21-440 76 00
Telefax: +351-21-440 76 90

Romania

GRUNDFOS Pompe România SRL
Bd. Biruintei, nr 103
Pantelimon county Ilfov
Phone: +40 21 200 4100
Telefax: +40 21 200 4101
E-mail: romania@grundfos.ro

Russia

ООО Грундфос Россия
ул. Школьная, 39-41
Москва, RU-109544, Russia
Тел. (+7) 495 564-88-00 (495)
737-30-00
Факс (+7) 495 564 8811
E-mail grundfos.moscow@grundfos.com

Serbia

Grundfos Srbija d.o.o.
Omladinskih brigada 90b
11070 Novi Beograd
Phone: +381 11 2258 740
Telefax: +381 11 2281 769
www.rs.grundfos.com

Singapore

GRUNDFOS (Singapore) Pte. Ltd.
25 Jalan Tukang
Singapore 619264
Phone: +65-6681 9688
Telefax: +65-6681 9689

Slovakia

GRUNDFOS s.r.o.
Prievozská 4D
821 09 BRATISLAVA
Phona: +421 2 5020 1426
sk.grundfos.com

Slovenia

GRUNDFOS LJUBLJANA, d.o.o.
Leskokoška 9e, 1122 Ljubljana
Phone: +386 (0) 1 568 06 10
Telefax: +386 (0) 1 568 06 19
E-mail: tehnika-si@grundfos.com

South Africa

Grundfos (PTY) Ltd.
16 Lascelles Drive, Meadowbrook Estate
1609 Germiston, Johannesburg
Tel.: (+27) 10 248 6000
Fax: (+27) 10 248 6002
E-mail: lgradidge@grundfos.com

Spain

Bombas GRUNDFOS España S.A.
Camino de la Fuentecilla, s/n
E-28110 Algete (Madrid)
Tel.: +34-91-848 8800
Telefax: +34-91-628 0465

Sweden

GRUNDFOS AB
Box 333 (Lunnagårdsgatan 6)
431 24 Mölndal
Tel.: +46 31 332 23 000
Telefax: +46 31 331 94 60

Switzerland

GRUNDFOS Pumpen AG
Bruggacherstrasse 10
CH-8117 Fällanden/ZH
Tel.: +41-44-806 8111
Telefax: +41-44-806 8115

Taiwan

GRUNDFOS Pumps (Taiwan) Ltd.
7 Floor, 219 Min-Chuan Road
Taichung, Taiwan, R.O.C.
Phone: +886-4-2305 0868
Telefax: +886-4-2305 0878

Thailand

GRUNDFOS (Thailand) Ltd.
92 Chaloeem Phrakiat Rama 9 Road,
Dokmai, Pravej, Bangkok 10250
Phone: +66-2-725 8999
Telefax: +66-2-725 8998

Turkey

GRUNDFOS POMPA San. ve Tic. Ltd.
Sti.
Gebze Organize Sanayi Bölgesi
İhsan dede Caddesi,
2. yol 200. Sokak No. 204
41490 Gebze/ Kocaeli
Phone: +90 - 262-679 7979
Telefax: +90 - 262-679 7905
E-mail: satis@grundfos.com

Ukraine

Бізнес Центр Європа
Столичне шосе, 103
м. Київ, 03131, Україна
Телефон: (+38 044) 237 04 00
Факс.: (+38 044) 237 04 01
E-mail: ukraine@grundfos.com

United Arab Emirates

GRUNDFOS Gulf Distribution
P.O. Box 16768
Jebel Ali Free Zone
Dubai
Phone: +971 4 8815 166
Telefax: +971 4 8815 136

United Kingdom

GRUNDFOS Pumps Ltd.
Grovebury Road
Leighton Buzzard/Beds. LU7 4TL
Phone: +44-1525-850000
Telefax: +44-1525-850011

U.S.A.

GRUNDFOS Pumps Corporation
9300 Loiret Blvd.
Lenexa, Kansas 66219
Phone: +1-913-227-3400
Telefax: +1-913-227-3500

Uzbekistan

Grundfos Tashkent, Uzbekistan The
Representative Office of Grundfos
Kazakhstan in Uzbekistan
38a, Oybek street, Tashkent
Телефон: (+998) 71 150 3290 / 71 150
3291
Факс: (+998) 71 150 3292

Addresses Revised 15.01.2019

97936207 0319

ECM: 1255243

Trademarks displayed in this material, including but not limited to Grundfos, the Grundfos logo and "be think innovate" are registered trademarks owned by The Grundfos Group. All rights reserved. © 2019 Grundfos Holding A/S, all rights reserved.