

Ponorná čerpadla do vrtu  
for 6", 8", 10", 12", 14", 18"

## Konstrukce

Ponorná čerpadla do vrtu 6" (DN 150 mm), 8" (DN 200 mm) a 10" (DN 250 mm), 12" (DN 300 mm), 14" (DN 350 mm), 18" (DN 450 mm), se stupněmi z litiny nebo oceli (na vyžádání).

## Oběžná kola

- Polosové SDS
- radiální SDR

## Připojení:

Závít ISO 228 pro SDS 6,8" - SDR 8,10", I-SDS 8,10", I-SDR 6"  
Přírubové s protipřírubou pro svařování pro SDS 10, 12, 14, 18", I-SDS 12"

Tlakové potrubí s vestavěným zpětným ventilem.

## Použití

- Pro vodovodní systémy.
- Pro civilní a průmyslové aplikace.
- Pro hašení požárů.
- Pro zavlažování.

## Provozní podmínky

Teplota kapaliny:  
až do 25 °C.

Maximální množství písku ve vodě:

- 100 g/m<sup>3</sup> SDS 6,8"
- 40 g/m<sup>3</sup> SDS 10,12,14,18"
- 150 g/m<sup>3</sup> I-SDS 6,8,10", I-SDR 6"

Trvalý provoz.

## Označení

Příklad: -10 SDS 64 / 2 A 8SM  
I = speciální vlastnosti z nerezové oceli (na vyžádání)  
10 = průměr studny v palcích  
SDS = řada  
64 = označení stupně  
2 = počet stupňů  
A = velikost oběžného kola  
8SM = příruba motoru

## Motor

2pólový indukční motor, 50 Hz (n ≈ 2900 ot./min).  
Dimenzován pro připojení k čerpadlům podle norem NEMA (10", 12" kromě).

Standardní napětí:

jednofázové 230 V – až 2,2 kW pro 4" motory.  
třífázové 230 V; 400 V, pro 4" motory.  
400 V; 400/690 V pro 6", 8", 10", 12" motory.

Tolerance napětí: ± 10 %

Aby bylo možné omezit proud a točivý moment při každém spuštění, je u motorů s jmenovitým výkonem 7,5 kW a vyšším nutné použít jeden z následujících typů spouštění: hvězda/trojúhelník, měkký startér, impedance statoru nebo autotransformátor.

Třída izolace: - F pro motory 4"

Krytí IP 68.

Instalace pod hladinou vody: 100 m pro 4", 150 m pro 6", 500 m pro 8,10" 4" motor

Motor je vhodný pro provoz s frekvenčním měničem (s vhodným filtrem dv/dt).

Horizontální instalace (kromě 6" 37-45 kW, 8" 92 kW, 10" 170-190 kW)

Motor	Motor P2	Max. teplota kapaliny teplota	Minimální rychlost proudění chladicího média	Max. počet spuštění za hodinu
4CS-R	všechny	35 °C	0,1 m/s	30
6CS-R	4+15 kW	40 °C	0,5 m/s	20
6CS-R	18,5+30 kW	35 °C	0,5 m/s	20
6CS-R	37 kW	30 °C	0,5 m/s	20
8CS-R	30+45 kW	30 °C	0,2 m/s	10
8CS-R	51 kW	30 °C	0,2 m/s	8
8CS-R	59+75 kW	30 °C	0,5 m/s	8
8CS-R	92+110 kW	30 °C	0,5 m/s	6
10CS-R	všechny	25 °C	0,5 m/s	6
12CS-R	všechny	25 °C	0,5 m/s	5

## Speciální vlastnosti na vyžádání

Jiné napětí.

Frekvence 60 Hz (podle datového listu 60 Hz).

Jiné teploty.

Oběžné kolo z nerezové oceli

Kapsulovaný motor řady FK.

## Materiály

Komponenty	6, 8, 10, 12, 14, 18 SDS	8, 10 SDR	I-6, I-8, I-10, I-12 SDS	I-6, SDR
Krytí stupně	Litina	Litina	Ocel (AISI 316)	Ocel (AISI 316)
Difuzor	Litina	Litina	Ocel (AISI 316)	Ocel (AISI 316)
Vnější plášť	-	-	-	Ocel (AISI 304)
Oběžné kolo	Litina (nerezová ocel pro 14" a 18SDS 64)	Litina (NORYL 8-SDR)	Nerezová ocel	Nerezová ocel
Opatřitelný kroužek	-	-	Nerezová ocel/Guma	Nerezová ocel/Guma
Hřídel	Nerezová ocel	Nerezová ocel	Ocel AISI F51duplex	Ocel AISI F51duplex
Bronzina	Bronz	Bronz	-	-
dodávací pouzdro	Litina	Litina	Nerezová ocel	Nerezová ocel
Sací lucerna	Litina	Litina	Nerezová ocel	Nerezová ocel
Ložisko stupně	Ocel (AISI 316)/NBR	Ocel (AISI 316)/NBR	Nerezová ocel	Guma
Filtr	Ocel (AISI 304)	Ocel (AISI 304)	Nerezová ocel	Nerezová ocel
Šrouby	Ocel	Ocel	Nerezová ocel	Nerezová ocel

Úplné informace o materiálech naleznete v průvodci výběrem čerpadel na webových stránkách společnosti Calpeda.

Coverage chart  $n \approx 2900$  rpm

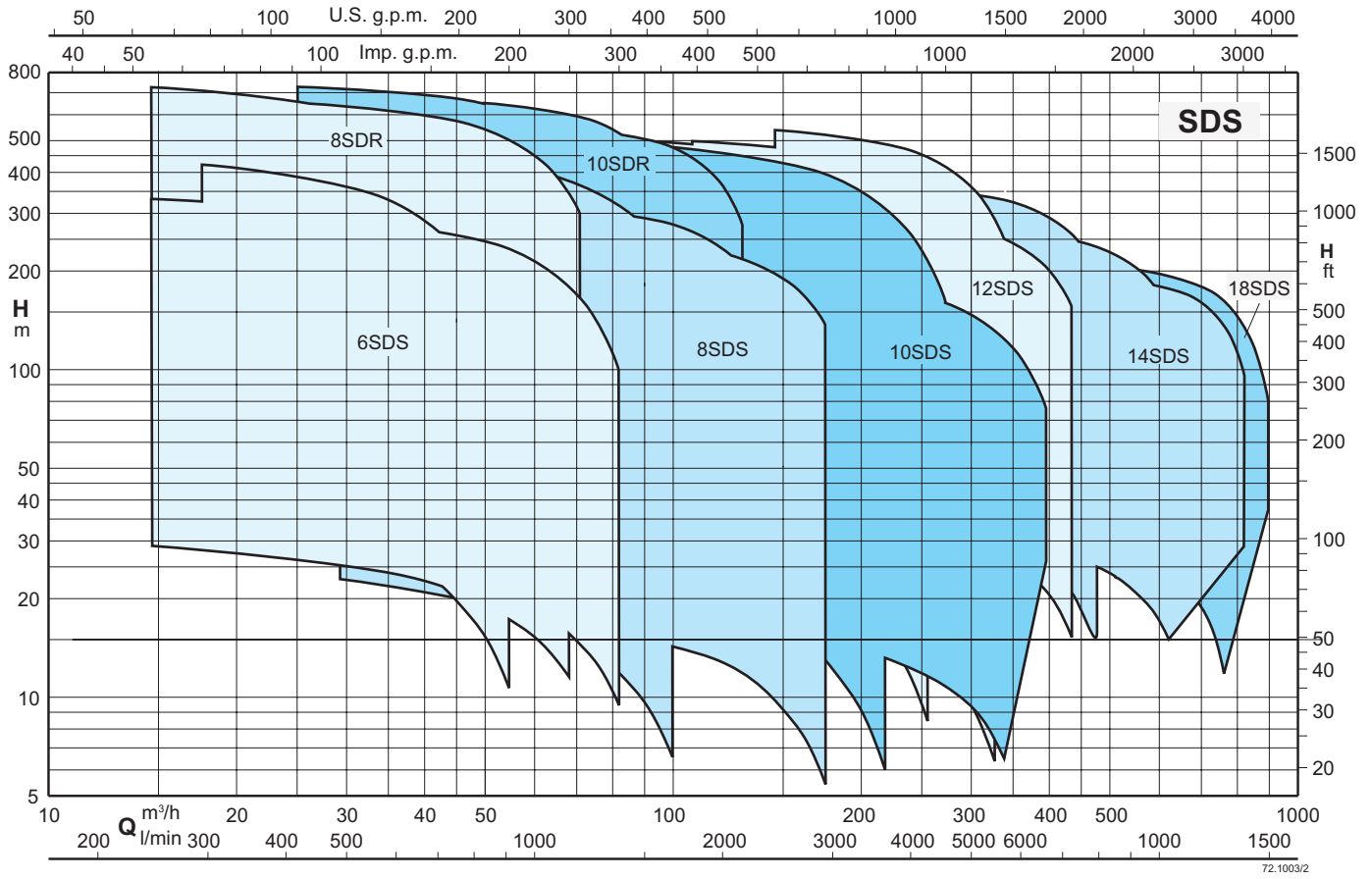

72.1003/2

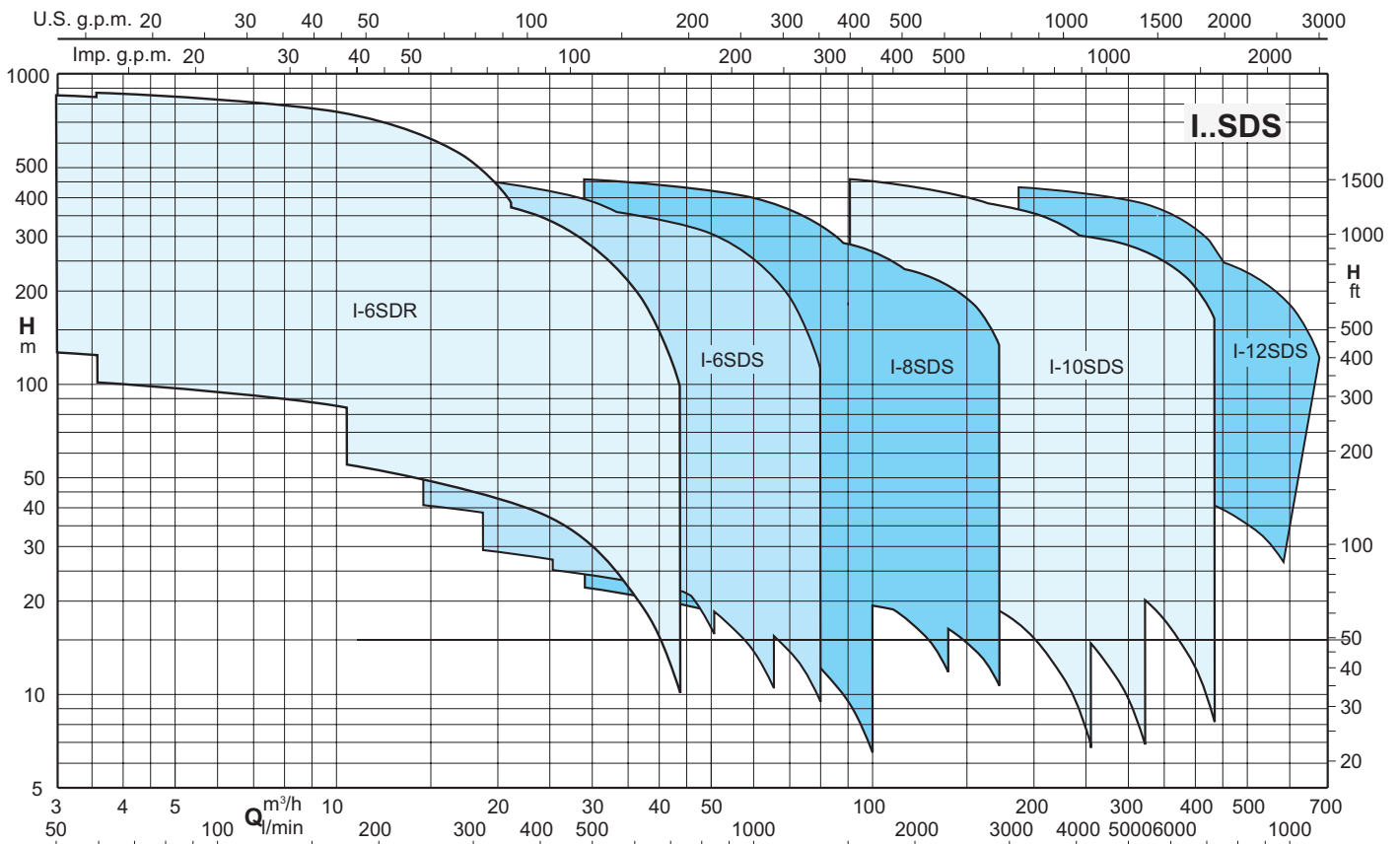

72.1003/2

### Coverage chart n ≈ 2900 rpm

Model			Q = Flow															
			m³/h	H (m) = Total head														
			l/min	0	18	20	22	24	26	28	30	32	34	36	38	40	42	44
P2			300	333	367	400	433	467	500	533	567	600	633	667	700	733	767	
kW	HP																	
6SDS 35/3I 6SM	4	5,5	40,2	37,6	37,3	36,8	36,3	35,6	34,8	33,9	32,9	31,7	30,3	28,8	27,1	25,2	23,1	20,8
6SDS 35/4I 6SM	5,5	7,5	54	50,4	49,9	49,2	48,4	47,5	46,4	45,2	43,8	42,1	40,3	38,2	35,9	33,4	30,6	27,5
6SDS 35/6L 6SM	7,5	10	77,5	72,3	71,5	70,5	69,3	67,9	66,3	64,4	62,2	59,7	56,8	53,7	50,1	46,2	41,9	37,2
6SDS 35/7N 6SM	9,2	12,5	94,4	88,2	87,3	86,3	85	83,5	81,7	79,6	77,2	74,4	71,3	67,8	63,8	59,4	54,5	49
6SDS 35/8A 6SM	11	15	111	105	104	102	101	98,7	96,6	94,2	91,5	88,4	84,8	80,7	76,2	71,2	65,6	59,6
6SDS 35/10M 6SM	13	17,5	134	125	124	122	121	118	116	113	109	105	99,7	94,4	88,5	82	74,9	67,2
6SDS 35/11I 6SM	15	20	151	142	140	139	137	134	131	128	124	120	115	109	103	95,6	87,8	79,3
6SDS 35/12A 6SM	18,5	25	167	157	155	153	151	148	145	142	137	132	127	120	113	106	97	88,1
6SDS 35/14M 6SM	18,5	25	189	176	174	172	169	166	162	158	153	147	141	134	126	117	107	95,8
6SDS 35/15A 6SM	22	30	208	196	194	191	189	186	182	177	172	166	159	151	142	132	122	110
6SDS 35/16A 6SM	22	30	222	208	206	203	201	197	193	188	183	176	168	160	150	139	128	116
6SDS 35/17A 6SM	26	35	237	223	221	218	215	212	208	203	197	190	182	172	162	151	138	125
6SDS 35/19A 6SM	26	35	264	247	245	242	239	235	229	223	216	208	199	189	178	166	153	139
6SDS 35/21A 6SM	30	40	292	272	269	266	262	257	252	246	239	231	221	211	199	185	171	154
6SDS 35/22A 6SM	30	40	305	285	282	279	275	270	264	257	249	239	229	217	204	190	175	158
6SDS 35/24A 6SM	37	50	333	312	309	305	300	295	289	281	273	263	251	239	224	209	192	174
6SDS 35/25A 6SM	37	50	346	324	321	317	312	307	300	292	283	272	260	247	232	216	199	181
6SDS 35/27A 6SM	37	50	374	347	343	338	333	327	320	311	302	291	278	264	248	231	212	191
6SDS 35/30A 6SM	45	60	415	388	384	379	373	366	358	349	339	326	313	297	280	260	240	217
6SDS 35/32A 6SM	45	60	442	411	407	401	395	387	379	369	357	344	330	313	295	275	253	229

Model			Q = Flow												
			m³/h	H (m) = Total head											
			l/min	0	18	20	22	24	26	28	30	35	40	45	50
P2			300	333	367	400	433	467	500	583	667	750	833	917	
kW	HP														
6SDS 45/2I 6SM	4	5,5	30,7	28,8	28,6	28,4	28,2	27,9	27,6	27,3	26,2	24,8	23,1	21,2	18,9
6SDS 45/3A 6SM	7,5	10	48,6	45,9	45,6	45,3	45	44,7	44,3	43,9	42,5	40,6	38,1	35,2	31,9
6SDS 45/3N 6SM	5,5	7,5	44,8	41,8	41,5	41,2	40,8	40,4	39,9	39,4	37,7	35,4	32,7	29,5	26
6SDS 45/4N 6SM	7,5	10	61	57,1	56,7	56,2	55,7	55,2	54,6	53,9	51,8	49,1	45,6	41,5	36,8
6SDS 45/5U 6SM	9,2	12,5	75,5	70,5	69,9	69,2	68,5	67,7	66,9	66	63,4	60	55,8	50,4	43,6
6SDS 45/6P 6SM	11	15	91,3	85,2	84,6	83,9	83,2	82,4	81,5	80,5	77,5	73,6	68,7	62,7	55,3
6SDS 45/7A 6SM	15	20	113	106	106	105	104	103	103	101	97,6	93	87,3	80,4	72,6
6SDS 45/7L 6SM	13	17,5	106	98,7	98	97,2	96,4	95,4	94,3	93,1	89,3	84,3	78,2	71,1	63,1
6SDS 45/8A 6SM	18,5	25	128	121	120	119	118	118	116	115	112	106	99,5	91,6	82,7
6SDS 45/9A 6SM	18,5	25	144	135	134	133	132	131	130	129	124	119	111	102	91,8
6SDS 45/11I 6SM	22	30	174	163	162	161	160	158	157	155	149	142	133	123	110
6SDS 45/13I 6SM	26	35	206	194	192	191	189	188	186	184	178	170	159	146	132
6SDS 45/14A 6SM	30	40	224	210	209	207	206	204	202	200	194	185	174	160	144
6SDS 45/16A 6SM	37	50	256	241	239	237	236	234	231	229	221	211	198	182	164
6SDS 45/18A 6SM	37	50	287	269	267	265	263	261	258	255	246	234	219	202	182
6SDS 45/20A 6SM	45	60	319	299	298	296	294	291	289	286	276	263	246	226	203
6SDS 45/22A 6SM	45	60	350	327	325	322	319	317	313	310	299	284	265	243	218

P2: Rated motor power output.

H: Total head in m

### Coverage chart n ≈ 2900 rpm

Model			Q = Flow												
			m³/h	0	28,8	35	40	45	50	55	60	65	70	75	81
			l/min		480	583	667	750	833	917	1000	1080	1170	1250	1350
P2		H (m) = Total head													
kW	HP														
6SDS 55/2A 6SM	4	5,5	28,7	25,1	24,4	23,6	22,7	21,6	20,2	18,6	16,7	14,6	12,4	9,5	
6SDS 55/3I 6SM	5,5	7,5	40,8	35,5	34,2	33	31,6	29,9	27,8	25,4	22,6	19,4	15,7	10,6	
6SDS 55/4A 6SM	7,5	10	57,3	49,8	47,8	46	44	41,7	39	35,9	32,3	28,2	23,7	17,9	
6SDS 55/5I 6SM	9,2	12,5	69,4	61	59	57	54,6	51,8	48,4	44,3	39,7	34,3	28,1	19,2	
6SDS 55/6I 6SM	11	15	83,6	73,4	70,7	68,2	65,1	61,6	57,3	52,4	46,8	40,4	33,2	23,3	
6SDS 55/7I 6SM	13	17,5	97,8	85,6	82,5	79,7	76,3	72,4	67,6	61,8	55	47,2	38,4	27,2	
6SDS 55/8I 6SM	15	20	112	98,1	94,4	91	87,2	82,8	77,4	71	63,4	54,5	44,5	31,7	
6SDS 55/9A 6SM	18,5	25	128	113	109	106	102	96,3	90,2	83	74,5	65	54,5	41	
6SDS 55/10A 6SM	18,5	25	142	124	120	115	110	104	97	88,9	79,8	69,6	58,5	44	
6SDS 55/12N 6SM	22	30	167	146	141	136	130	123	115	105	92,8	79,8	64,9	43,9	
6SDS 55/13A 6SM	26	35	185	164	159	154	148	141	132	121	108	94,1	79,1	59,7	
6SDS 55/14A 6SM	26	35	199	175	169	164	157	149	139	128	115	99,7	83,8	63,2	
6SDS 55/15A 6SM	30	40	213	187	181	176	169	160	150	137	123	107	89,2	67,2	
6SDS 55/16A 6SM	30	40	226	199	192	186	179	170	159	145	130	113	94,5	70,9	
6SDS 55/17A 6SM	37	50	242	213	206	200	192	182	170	156	140	122	103	76,7	
6SDS 55/19A 6SM	37	50	269	235	227	220	211	201	187	172	153	133	110	81,5	
6SDS 55/21A 6SM	45	60	298	262	254	246	236	224	210	193	173	150	126	94,2	
6SDS 55/23A 6SM	45	60	325	284	275	266	255	242	226	208	186	162	135	100	

Model			Q = Flow												
			m³/h	0	28,8	35	40	45	50	60	70	80	90	96	
			l/min		480	583	667	750	833	1000	1170	1330	1500	1600	
P2		H (m) = Total head													
kW	HP														
8SDS 65/1D 6SM	4	5,5	24,9	22,7	22,2	21,8	21,2	20,4	18,6	16,2	13,4	10,2	8		
8SDS 65/1A 6SM	5,5	7,5	29,4	26,8	26,3	25,9	25,3	24,7	23,2	21,1	18,5	15,5	13,3		
8SDS 65/2T 6SM	7,5	10	47,5	43,3	42,2	41,2	39,9	38,4	34,7	30	24,4	17,5	12,1		
8SDS 65/2C 6SM	9,2	12,5	54,3	49,5	48,5	47,6	46,4	45,1	41,7	37,1	31,6	25,1	20,6		
8SDS 65/2A 6SM	11	15	58,7	53,5	52,5	51,7	50,7	49,5	46,5	42,5	37,4	31,2	26,9		
8SDS 65/3K 6SM	15	20	84,9	78,1	76,4	75	73,3	71,4	66,6	60,4	52,6	43,3	37,2		
8SDS 65/3JD 6SM	13	17,5	78,6	71,9	70,2	68,7	67	65	59,9	53,1	44,6	34,1	26,8		
8SDS 65/3E 6SM	11	15	67,7	62,5	61,1	59,7	57,9	55,7	50,1	42,7	33,8	23,2	15,9		
8SDS 65/4JC 6SM	18,5	25	110	101	98,4	96,3	94,1	91,5	85	76,5	65,7	53	44,7		
8SDS 65/4A 6SM	22	30	117	108	105	103	101	98	91,9	83,9	73,4	60,4	51,8		
8SDS 65/5KC 6SM	22	30	132	122	120	118	115	111	103	90,4	76,1	58,8	46,2		
8SDS 65/5A 6SM	26	35	146	134	132	130	127	124	117	106	92,3	76,1	65,3		
8SDS 65/6U 6SM	30	40	170	156	152	149	146	143	134	122	105	83,7	70,2		
8SDS 65/6U 8SM	30	40	171	158	155	152	149	146	136	123	107	87,1	74		
8SDS 65/6C 6SM	30	40	162	149	146	144	141	137	128	114	96	75,4	61,7		
8SDS 65/6C 8SM	30	40	163	151	148	146	143	139	129	116	98,8	78,9	65,4		
8SDS 65/7A 6SM	37	50	204	187	183	180	176	172	161	147	128	106	90,2		
8SDS 65/7A 8SM	37	50	205	189	186	183	179	176	166	152	133	110	94		
8SDS 65/9T 6SM	45	60	250	230	225	220	215	210	195	176	151	118	93,3		
8SDS 65/9T 8SM	45	60	253	234	230	226	222	217	202	183	158	127	103		
8SDS 65/10Z 8SM	51	70	287	265	260	256	251	245	230	208	181	148	126		
8SDS 65/11A 8SM	59	80	324	298	293	289	283	277	262	240	211	175	150		
8SDS 65/12A 8SM	66	90	353	325	319	314	309	302	285	261	230	190	164		
8SDS 65/14A 8SM	75	100	411	377	370	364	358	350	331	303	266	219	188		
8SDS 65/16A 8SM	92	125	470	432	424	417	410	401	379	348	306	252	216		
8SDS 65/17A 8SM	92	125	498	458	449	442	434	425	401	368	323	265	227		

**P2:** Rated motor power output.  
**H:** Total head in m

## Coverage chart n ≈ 2900 rpm

Model			Q = Flow												
			m³/h	0	54	60	65	70	75	80	90	100	110	120	132
			l/min		900	1000	1080	1170	1250	1330	1500	1670	1830	2000	2200
P2		H (m) = Total head													
kW	HP														
8SDS 95/1C 6SM	7.5	10	27,4	25,1	24,7	24,3	23,9	23,4	22,9	21,6	20,1	18,3	16,2	13,3	
8SDS 95/1A 6SM	9,2	12,5	30	27,1	26,8	26,6	26,4	26	25,7	24,7	23,4	21,7	19,6	16,6	
8SDS 95/2F 6SM	9,2	12,5	38,2	34,9	33,8	32,7	31,5	30,2	28,7	25,3	21,3	16,6	-	-	
8SDS 95/2DF 6SM	11	15	44,4	40,9	40,1	39,2	38,1	36,9	35,5	32,3	28,5	24	-	-	
8SDS 95/2D 6SM	13	17,5	50,6	46,8	46,1	45,4	44,5	43,4	42,2	39,1	35,4	31	26,1	19,2	
8SDS 95/2C 6SM	15	20	54,8	50,6	49,8	49	48,1	47,2	46,1	43,5	40,5	36,9	32,8	26,8	
8SDS 95/2A 6SM	18,5	25	59,8	54,3	53,7	53,1	52,5	51,7	50,9	48,8	46,1	42,7	38,7	32,9	
8SDS 95/3DJ 6SM	18,5	25	71,7	66,9	65,8	64,6	63,2	61,5	59,5	54,9	49,3	42,9	35,8	25,7	
8SDS 95/3C 6SM	22	30	82	75,7	74,5	73,3	72,1	70,6	69	65,3	60,6	54,9	48,1	38,9	
8SDS 95/3A 6SM	26	35	89,8	82,4	81,5	80,6	79,5	78,3	76,9	73,6	69,5	64,5	58,7	50,1	
8SDS 95/4D 6SM	26	35	101	94,2	92,6	90,9	89	86,7	84,1	78	70,7	62,3	52,7	39,2	
8SDS 95/4C 6SM	30	40	109	102	99,6	98	96,3	94,3	92,1	86,9	80,7	73,4	64,9	52,8	
8SDS 95/4C 8SM	30	40	110	102	101	98,9	97,3	95,4	93,3	88,2	82	74,6	66	53,9	
8SDS 95/4A 6SM	37	50	119	110	109	107	106	105	103	98	92,3	85,2	76,8	64,9	
8SDS 95/4A 8SM	37	50	120	112	110	109	108	107	105	101	94,9	88,2	80,1	68,6	
8SDS 95/5KC 6SM	37	50	134	125	123	121	118	116	113	106	97,7	88	76,7	60,4	
8SDS 95/5KC 8SM	37	50	135	127	125	123	121	119	116	109	101	91,2	80,2	63,9	
8SDS 95/5A 6SM	45	60	149	137	136	134	132	130	128	122	115	106	95,2	80,7	
8SDS 95/5A 8SM	45	60	150	139	137	136	135	133	131	126	119	111	101	85,6	
8SDS 95/6QC 6SM	45	60	161	150	148	146	143	140	136	127	117	106	92	72,6	
8SDS 95/6QC 8SM	45	60	163	151	149	147	145	142	139	132	122	111	96,7	77,4	
8SDS 95/7ZC 8SM	51	70	186	174	172	169	166	163	159	149	138	124	109	84,9	
8SDS 95/7Z 8SM	59	80	203	188	186	184	182	179	176	168	158	146	131	111	
8SDS 95/8Z 8SM	66	90	233	215	212	210	207	204	201	192	181	167	150	126	
8SDS 95/10XC 8SM	75	100	273	254	250	246	242	237	232	219	204	185	163	131	
8SDS 95/10A 8SM	92	125	300	277	274	271	268	265	260	250	237	220	199	170	
8SDS 95/12C 8SM	92	125	329	308	304	300	295	289	282	266	247	225	200	165	

Model			Q = Flow											
			m³/h	0	72	80	90	100	120	130	140	150	160	168
			l/min		1200	1330	1500	1670	2000	2170	2330	2500	2670	2800
P2		H (m) = Total head												
kW	HP													
8SDS 135/1F 6SM	5.5	7.5	20,4	17,1	16,6	15,8	14,9	12,6	11,4	10,1	8,8	7,3	6	
8SDS 135/1D 6SM	7.5	10	24,5	21,2	20,8	20,1	19,3	17,4	16,3	15,2	14	12,7	11,6	
8SDS 135/1B 6SM	9,2	12,5	27,2	23,9	23,4	22,8	22,1	20,2	19	17,8	16,5	15,1	14,1	
8SDS 135/2G 6SM	9,2	12,5	36,9	30,1	29	27,3	25,4	20,7	18,1	15,3	12,5	9,6	7,3	
8SDS 135/2F 6SM	11	15	40,8	34,3	33,2	31,7	29,8	25,5	23,2	20,7	18	14,9	11,9	
8SDS 135/2E 6SM	13	17,5	44,9	38,3	37,3	35,9	34,3	30,3	28	25,5	22,9	20,2	18	
8SDS 135/2D 6SM	15	20	48,9	42	41,1	39,7	38,2	34,4	32,3	29,9	27,4	24,9	22,7	
8SDS 135/2B 6SM	18,5	25	54,1	47,2	46,4	45,1	43,5	39,7	37,4	34,9	32,3	29,7	27,5	
8SDS 135/3E 6SM	18,5	25	66,9	56,9	55,5	53,5	51,1	45,1	41,6	37,7	33,7	29,5	26,3	
8SDS 135/3D 6SM	22	30	73	62,5	61	59,1	56,8	51,5	48,3	44,7	40,9	36,8	33,4	
8SDS 135/3B 6SM	26	35	81,2	70,5	69,1	67,2	65	59,5	56,2	52,5	48,5	44,4	41,1	
8SDS 135/4D 6SM	30	40	97,4	83,4	81,5	78,8	75,9	68,7	64,4	59,7	54,6	49,1	44,6	
8SDS 135/4D 8SM	30	40	97,9	84,6	82,7	80	76,9	69,6	65,3	60,8	55,9	50,5	45,8	
8SDS 135/4C 6SM	37	50	105	91,4	89,5	86,8	83,8	76,4	72,2	67,6	62,7	57,3	52,3	
8SDS 135/4C 8SM	37	50	106	93,1	91,4	88,8	85,7	78,3	74,1	69,6	64,8	59,5	54,6	
8SDS 135/5D 6SM	37	50	121	105	102	98,5	94,7	85,3	79,8	73,8	67,4	60,6	55	
8SDS 135/5D 8SM	37	50	123	106	104	101	96,3	87,4	82,3	76,6	70,5	63,8	57,9	
8SDS 135/5B 6SM	45	60	135	117	115	111	108	97,8	92,3	86,1	79,5	72,5	66,8	
8SDS 135/5B 8SM	45	60	136	120	117	114	111	102	95,9	89,4	82,4	75,4	70,1	
8SDS 135/6C 8SM	51	70	159	139	137	133	129	117	111	104	96,4	88,3	81	
8SDS 135/7C 8SM	59	80	186	163	160	155	150	137	129	122	114	104	95,2	
8SDS 135/7A 8SM	66	90	197	173	170	166	161	148	140	132	122	112	104	
8SDS 135/8C 8SM	66	90	212	186	183	178	172	157	148	138	128	117	107	
8SDS 135/8A 8SM	75	100	224	198	194	189	183	168	159	150	139	128	119	
8SDS 135/9C 8SM	75	100	238	208	204	198	191	175	165	155	143	131	120	
8SDS 135/10C 8SM	92	125	265	232	228	221	213	195	185	173	161	147	135	
8SDS 135/11C 8SM	92	125	290	254	249	242	234	214	202	190	176	161	148	

**P2:** Rated motor power output.  
**H:** Total head in m

**Coverage chart n ≈ 2900 rpm**

Model	P2		Q = Flow															
			m³/h															
			l/min	0	18	20	21	22	23	24	26	28	30	32	34	36	38	40
	kW	HP		300	333	350	367	383	400	433	467	500	533	567	600	633	667	
			H (m) = Total head															
8SDR 35/11A 6SM	22	30		234	213	209	207	204	202	199	193	187	179	171	163	153	143	132
8SDR 35/13A 6SM	26	35		277	253	248	246	243	240	237	230	222	214	205	195	184	172	160
8SDR 35/15A 6SM	30	40		323	299	294	291	288	284	280	272	263	252	241	229	217	203	189
8SDR 35/15A 8SM	30	40		323	299	294	291	288	284	280	272	263	252	241	229	217	203	189
8SDR 35/17A 6SM	37	50		364	333	327	324	321	317	313	304	293	282	270	256	242	226	210
8SDR 35/17A 8SM	37	50		368	341	335	332	328	324	320	312	302	291	279	266	251	236	219
8SDR 35/19A 6SM	37	50		406	369	362	358	354	349	345	334	323	310	296	281	264	247	228
8SDR 35/19A 8SM	37	50		410	379	372	368	364	360	355	345	334	321	307	292	276	259	241
8SDR 35/23A 6SM	45	60		490	446	437	433	428	423	417	404	390	375	358	339	319	298	276
8SDR 35/23A 8SM	45	60		496	458	450	445	440	435	429	417	404	388	372	354	335	314	292
8SDR B35/27A 8SM	51	70		581	532	522	516	510	504	498	484	468	451	432	411	389	365	339
8SDR B35/31A 8SM	59	80		667	614	604	598	592	585	578	563	545	525	503	479	452	423	391
8SDR B35/35A 8SM	66	90		753	691	678	672	665	657	649	631	611	588	563	535	504	471	436

Model	P2		Q = Flow									
			m³/h									
			l/min	0	28,8	30	35	40	45	50	55	60
	kW	HP		480	500	583	667	750	833	917	1000	
			H (m) = Total head									
8SDR 40/6A 6SM	22	30		144	126	125	121	117	111	103	94,3	84,1
8SDR 40/7A 6SM	26	35		168	147	146	142	136	130	122	112	100
8SDR 40/8A 6SM	26	35		194	171	170	164	158	150	140	128	115
8SDR 40/9A 6SM	30	40		215	189	187	181	174	166	155	143	128
8SDR 40/9A 8SM	30	40		217	191	190	184	177	169	158	145	130
8SDR 40/11A 6SM	37	50		263	230	228	221	213	202	189	173	154
8SDR 40/11A 8SM	37	50		267	234	233	226	218	208	195	179	160
8SDR 40/13A 6SM	45	60		310	273	271	263	253	240	224	206	183
8SDR 40/13A 8SM	45	60		315	277	275	267	258	246	231	213	191
8SDR 40/15A 8SM	51	70		363	318	316	307	297	283	265	243	218
8SDR 40/17A 8SM	59	80		409	358	356	346	334	318	298	273	244
8SDR 40/19A 8SM	66	90		459	403	401	390	376	358	336	308	276
8SDR B40/21A 8SM	75	100		507	445	442	430	414	395	370	340	305
8SDR B40/23A 8SM	75	100		555	487	484	469	453	432	406	374	336
8SDR B40/25A 8SM	92	125		604	530	526	511	493	470	441	405	361
8SDR B40/28A 8SM	92	125		674	590	586	568	547	521	488	446	397
8SDR B40/30A 8SM	110	150		726	642	638	621	599	571	536	493	442

**P2:** Rated motor power output.  
**H:** Total head in m

## Coverage chart n ≈ 2900 rpm

Model	P2		Q = Flow																
			m³/h	H (m) = Total head															
				l/min	0	54	60	70	80	90	100	110	120	130	140	150	160	180	200
	kW	HP		900	1000	1170	1330	1500	1670	1830	2000	2170	2330	2500	2670	3000	3330	3600	
10SDS 50/1H 6SM	9,2	12,5	27,2	23,6	23,3	22,8	22,2	21,7	21,1	20,4	19,6	18,6	17,5	16,1	14,5	10,2	-	-	
10SDS 50/1F 6SM	11	15	29,7	-	-	-	-	24,2	23,8	23,3	22,7	22	21,1	19,9	18,6	15,1	10,6	6,5	
10SDS 50/1D 6SM	13	17,5	34,8	-	-	-	-	29,3	28,7	28	27,2	26,3	25,4	24,3	23,1	20,2	16,7	13,3	
10SDS 50/1B 6SM	15	20	36,5	-	-	-	-	30,3	29,8	29,3	28,7	28	27,3	26,5	25,5	23,1	19,7	15,9	
10SDS 50/2G 6SM	18,5	25	54,7	-	-	-	-	44,5	43,2	41,7	40	38,1	35,9	33,5	30,9	25	18,4	12,7	
10SDS 50/2E 6SM	22	30	62,8	-	-	-	-	52	50,7	49,3	47,6	45,8	43,7	41,3	38,7	32,7	25,6	18,7	
10SDS 50/2CD 6SM	26	35	67,9	-	-	-	-	57,5	56	54,2	52,2	50	47,6	45	42,2	36,2	30	24,8	
10SDS 50/2B 6SM	30	40	69,9	-	-	-	-	62	60,8	59,5	57,9	56,1	54,1	51,8	49,3	43,6	36,9	31	
10SDS 50/2B 8SM	30	40	73,3	-	-	-	-	63,6	62,4	61,1	59,6	57,9	56,1	54	51,7	46,2	39,3	32,4	
10SDS 50/3D 6SM	37	50	98,5	-	-	-	-	83,3	81,3	79,1	76,6	73,9	70,8	67,4	63,7	55,3	45,8	37,4	
10SDS 50/3D 8SM	37	50	101	-	-	-	-	85,7	83,9	81,8	79,5	76,8	73,9	70,5	66,7	57,7	46,7	36,5	
10SDS 50/3B 6SM	45	60	108	-	-	-	-	92,6	90,8	88,8	86,6	84,2	81,4	78,3	74,8	66,4	55,7	45	
10SDS 50/3B 8SM	45	60	110	-	-	-	-	95,3	93,4	91,4	89,2	86,6	83,8	80,7	77,1	68,8	58,5	48,2	
10SDS 50/4CD 8SM	51	70	137	-	-	-	-	117	114	111	108	104	99,7	95,3	90,3	78,7	64,5	50,7	
10SDS 50/4B 8SM	59	80	145	-	-	-	-	126	123	121	117	114	110	106	101	90,2	76,5	62,5	
10SDS 50/5CD 8SM	66	90	171	-	-	-	-	146	142	139	135	130	125	120	114	98,7	80,9	63,5	
10SDS 50/5B 8SM	75	100	183	-	-	-	-	159	156	153	149	145	140	135	129	115	97,8	80,6	
10SDS 50/6C 8SM	92	125	213	-	-	-	-	183	180	176	171	166	160	154	147	131	110	89,1	
10SDS 50/7CD 8SM	92	125	242	-	-	-	-	208	203	199	193	187	180	173	164	144	119	94,7	
10SDS 50/8C 8SM	110	150	287	-	-	-	-	235	231	226	221	216	209	202	193	172	145	120	
10SDS 50/8B 8SM	132	180	295	-	-	-	-	259	254	249	244	238	230	222	213	192	165	138	
10SDS 50/9BC 8SM	132	180	315	-	-	-	-	283	279	274	267	259	250	240	228	202	172	146	
10SDS 50/10B 8SM	150	200	356	-	-	-	-	322	317	311	303	294	283	271	258	229	196	168	
10SDS 50/11B 8SM	165	220	391	-	-	-	-	354	348	342	333	323	312	299	284	253	218	187	
10SDS 50/12JC 8SM	185	250	424	-	-	-	-	383	377	370	361	350	338	325	309	276	237	203	
10SDS 50/12JC 12SM	170	230	425	-	-	-	-	385	378	371	362	351	339	325	310	275	235	201	
10SDS 50/13B 12SM	190	260	463	-	-	-	-	421	414	406	396	385	371	356	339	300	258	221	
10SDS 50/13B 8SM	185	250	463	-	-	-	-	417	410	402	393	383	370	356	341	304	260	221	
10SDS 50/14B 12SM	220	300	498	-	-	-	-	453	446	438	428	416	402	386	369	329	282	239	
10SDS 50/15B 12SM	220	300	533	-	-	-	-	482	474	465	455	443	429	412	394	350	299	254	

Model	P2		Q = Flow													
			m³/h	H (m) = Total head												
				l/min	0	99	120	130	140	150	160	170	180	190	200	220
	kW	HP		1650	2000	2170	2330	2500	2670	2830	3000	3170	3330	3670	4000	4200
10SDS 55/2B 6SM	30	40	64,2	54,8	52,6	51,4	49,9	48,2	46,4	44,3	42	39,6	37	31,6	25,9	22,2
10SDS 55/2B 8SM	30	40	64,9	55,6	53,7	52,6	51,2	49,6	47,9	45,9	43,7	41,5	39	33,9	28,4	24,7
10SDS 55/2A 6SM	37	50	68,7	58,9	56,1	54,6	53	51,3	49,5	47,6	45,5	43,4	41,2	36,3	30,9	27,3
10SDS 55/2A 8SM	37	50	70,9	61,3	58,9	57,6	56,1	54,5	52,7	50,8	48,6	46,2	43,7	38,1	32,1	28,5
10SDS 55/3K 6SM	45	60	98,7	83,2	79,6	77,6	75,5	73,2	70,7	67,9	64,9	61,7	58,3	50,7	42,2	36,5
10SDS 55/3K 8SM	45	60	99,9	85,7	82,5	80,6	78,5	76,1	73,5	70,5	67,2	63,7	59,9	51,8	43,1	37,6
10SDS 55/3C 6SM	37	50	88,9	74,5	70,5	68,4	66	63,6	60,9	58,1	55,1	51,9	48,6	41,5	33,7	28,6
10SDS 55/3C 8SM	37	50	91,6	78,5	75,5	73,6	71,4	68,9	66	62,8	59,3	55,5	51,6	43,2	34,5	29
10SDS 55/3A 8SM	51	70	106	92,4	88,7	86,6	84,4	82	79,3	76,3	73,1	69,6	65,8	57,5	48,3	42,6
10SDS 55/4S 8SM	51	70	125	107	103	101	97,3	93,8	90	85,7	81,1	76,1	70,9	59,9	48,2	40,7
10SDS 55/4K 8SM	59	80	134	115	110	107	104	101	96,8	92,7	88,3	83,5	78,3	67	54,5	46,4
10SDS 55/4A 8SM	66	90	141	125	120	118	115	111	108	104	98,6	93,7	88,5	77	64,4	56,4
10SDS 55/5A 8SM	75	100	176	149	143	139	136	132	127	122	117	112	106	92,2	77,9	68,5
10SDS 55/6A 8SM	92	125	213	184	177	173	169	164	159	153	147	140	132	116	97,4	86,1
10SDS 55/7A 8SM	110	150	242	211	201	196	191	185	179	172	165	157	149	132	113	101
10SDS 55/8A 8SM	132	180	279	246	237	232	226	220	213	205	197	188	178	157	135	120
10SDS 55/9K 8SM	132	180	309	269	260	254	248	241	233	224	215	205	194	171	147	132
10SDS 55/10A 8SM	150	200	349	304	294	288	281	274	265	256	246	235	223	198	170	151
10SDS 55/11A 8SM	185	250	385	338	325	318	310	301	292	281	270	258	245	217	186	166
10SDS 55/11A 12SM	170	230	385	341	328	322	314	305	295	284	272	259	246	217	186	166
10SDS 55/12A 12SM	190	260	420	371	357	350	341	331	321	309	296	283	268	237	203	181
10SDS 55/12A 8SM	185	250	420	369	354	345	336	326	315	304	292	279	265	236	202	180
10SDS 55/13A 12SM	220	300	454	401	385	377	368	358	347	335	322	308	293	260	222	195
10SDS 55/14A 12SM	220	300	489	430	413	403	392	381	369	356	342	327	311	277	238	209
10SDS 55/15A 12SM	250	340	524	460	443	434	424	412	399	385	370	354	336	296	251	220

**P2:** Rated motor power output.  
**H:** Total head in m

### Coverage chart n ≈ 2900 rpm

Model			Q = Flow															
			m³/h	0	162	180	200	220	240	260	288	300	320	338	350	360	368	385
			l/min		2700	3000	3330	3670	4000	4330	4800	5000	5330	5630	5830	6000	6130	6420
P2		H (m) = Total head																
kW	HP																	
10SDS 64/1H 6SM	13	17,5	26,3	16,6	16	15,3	14,5	13,6	12,3	9,8	-	-	-	-	-	-	-	
10SDS 64/1G 6SM	15	20	28,7	19,8	19,1	18,3	17,5	16,3	14,8	12,1	-	-	-	-	-	-	-	
10SDS 64/1EF 6SM	18.5	25	32,3	23,6	22,7	21,7	20,7	19,4	18	15,6	14,3	-	-	-	-	-	-	
10SDS 64/1CD 6SM	22	30	37,4	28,6	27,8	27	26	24,9	23,5	21,1	19,9	17,6	15,4	-	-	-	-	
10SDS 64/1BC 6SM	26	35	40,4	31,4	30,5	29,5	28,5	27,3	26	23,8	22,7	20,7	18,6	17,1	15,7	-	-	
10SDS 64/1A 6SM	30	40	45,6	34,7	33,7	32,7	31,8	30,9	29,9	28,1	27,2	25,3	23,3	21,8	20,5	19,4	-	
10SDS 64/1A 8SM	30	40	46,4	35,5	34,5	33,5	32,5	31,5	30,4	28,6	27,6	25,9	24	22,6	21,4	20,4	-	
10SDS 64/2EF 6SM	37	50	65	49,9	48,1	46	43,8	41,3	38,6	33,9	31,6	27	-	-	-	-	-	
10SDS 64/2EF 8SM	37	50	65	49,9	48,1	46	43,8	41,3	38,6	33,9	31,6	27	-	-	-	-	-	
10SDS 64/2CD 6SM	45	60	64,2	57,8	56,4	54,6	52,5	50	47,1	42,4	40,1	35,8	31,5	-	-	-	-	
10SDS 64/2CD 8SM	45	60	74,7	59	57,5	55,7	53,7	51,5	48,7	44	41,6	37,3	33	-	-	-	-	
10SDS 64/2BC 8SM	51	70	80,4	64,5	62,9	61	58,9	56,4	53,6	49	46,8	42,8	38,8	35,8	33,1	-	-	
10SDS 64/2A 8SM	59	80	90,3	71	69,2	67,3	65,3	63,3	61	56,9	54,8	50,8	46,6	43,5	40,9	38,8	-	
10SDS 64/3D 8SM	66	90	106	87,1	84,7	81,6	78,1	74,1	69,6	62,1	58,6	52,1	45,7	41,2	37,2	-	-	
10SDS 64/3C 8SM	75	100	114	95,5	93	89,9	86,3	82,2	77,7	70,4	66,9	60,7	54,4	49,8	45,6	42,1	-	
10SDS 64/3A 8SM	92	125	136	-	111	108	104	99,9	95,8	89,4	86,3	80,7	74,9	70,7	66,9	63,8	56,4	
10SDS 64/4B 8SM	110	150	147	-	135	131	126	120	114	104	99,1	91,3	83,5	77,6	72	67,1	-	
10SDS 64/4A 8SM	132	180	182	-	148	144	139	134	129	120	116	108	101	94,7	89,9	85,8	76,4	
10SDS 64/5BC 8SM	132	180	203	170	166	161	155	148	140	128	123	113	103	94,7	88,1	82,4	-	
10SDS 64/5K 8SM	150	200	223	-	181	176	170	163	156	144	139	130	120	113	107	101	88	

Model			Q = Flow										
			m³/h	0	28,8	35	40	45	50	55	60	65	70
			l/min		480	583	667	750	833	917	1000	1080	1170
P2		H (m) = Total head											
kW	HP												
10SDR 30/5A 8SM	30	40	190	175	170	165	158	151	143	133	122	110	
10SDR 30/6A 8SM	37	50	229	211	205	199	192	183	173	162	149	134	
10SDR 30/8M 8SM	45	60	286	265	255	246	236	224	211	196	178	157	
10SDR 30/9K 8SM	51	70	330	304	293	283	272	259	244	226	206	184	
10SDR 30/10A 8SM	59	80	378	347	336	326	313	299	282	263	242	217	
10SDR 30/11A 8SM	66	90	421	389	378	367	353	338	319	299	275	248	
10SDR 30/13M 8SM	75	100	476	436	424	410	394	374	352	326	299	267	
10SDR 30/14A 8SM	92	125	534	491	481	469	453	432	407	378	348	314	
10SDR 30/15A 8SM	92	125	572	527	512	497	478	456	431	402	370	333	
10SDR B30/16A 8SM	110	150	611	561	548	533	513	489	462	431	397	359	
10SDR B30/17A 8SM	110	150	648	593	578	563	543	518	488	454	416	374	
10SDR B30/18A 8SM	110	150	684	626	610	592	570	544	514	481	443	399	
10SDR B30/19A 8SM	132	180	741	673	657	642	622	597	567	532	491	446	
10SDR B30/20A 8SM	132	180	779	707	691	674	653	627	595	558	515	467	

P2: Rated motor power output.  
H: Total head in m

Coverage chart n ≈ 2900 rpm

Model			Q = Flow											
			m³/h	0	62	70	75	80	85	90	95			
			l/min		1030	1170	1250	1330	1420	1500	1580			
P2		H (m) = Total head												
kW	HP													
10SDR 35/5A 8SM	37	50		178	137	126	118	109	99,1	89,4	79,3			
10SDR 35/6A 8SM	37	50		211	160	146	136	126	115	103	91			
10SDR 35/7A 8SM	45	60		248	188	172	160	148	135	122	108			
10SDR 35/8A 8SM	51	70		283	214	196	182	168	154	138	123			
10SDR 35/9A 8SM	59	80		320	242	221	206	190	173	156	137			
10SDR 35/10A 8SM	66	90		357	273	251	235	217	199	179	159			
10SDR 35/11A 8SM	75	100		392	303	278	261	241	221	200	178			
10SDR 35/12A 8SM	92	125		427	328	301	282	261	239	216	191			
10SDR 35/13A 8SM	92	125		461	354	324	303	280	256	231	205			
10SDR B35/14A 8SM	92	125		497	378	346	324	299	273	246	218			
10SDR B35/15A 8SM	110	150		533	409	374	350	323	296	267	236			
10SDR B35/16A 8SM	110	150		565	430	392	364	335	304	273	241			
10SDR B35/17A 8SM	110	150		601	458	418	389	359	327	294	261			
10SDR B35/18A 8SM	132	180		644	503	462	433	400	366	330	293			
10SDR B35/19A 8SM	132	180		680	532	489	458	424	387	348	309			
10SDR B35/20A 8SM	132	180		715	558	513	480	444	405	365	324			
10SDR B35/21A 8SM	150	200		753	589	542	507	469	428	386	343			

Model			Q = Flow													
			m³/h	0	62	70	75	80	85	90	95	100	110	120	132	
			l/min		1030	1170	1250	1330	1420	1500	1580	1670	1830	2000	2200	
P2		H (m) = Total head														
kW	HP															
10SDR 40/4B 8SM	30	40		114	101	97,8	95,4	92,5	89,1	85,2	80,9	76,2	65,5	53,8	39,3	
10SDR 40/4A 8SM	37	50		148	125	121	119	116	113	109	105	101	90,4	79	61,9	
10SDR 40/5I 8SM	45	60		177	150	146	143	139	135	130	125	120	106	91,4	73,2	
10SDR 40/6K 8SM	51	70		205	174	169	165	161	156	150	144	137	121	103	79,5	
10SDR 40/7M 8SM	59	80		232	198	192	187	182	176	170	162	154	136	117	92,9	
10SDR 40/8AB 8SM	66	90		262	225	218	213	207	200	193	184	175	154	131	101	
10SDR 40/8A 8SM	75	100		296	251	244	239	233	227	219	211	202	181	156	123	
10SDR 40/9A 8SM	92	125		334	283	274	268	261	253	245	236	226	204	178	141	
10SDR 40/10A 8SM	92	125		370	312	302	296	288	280	270	260	249	224	195	153	
10SDR 40/11A 8SM	110	150		407	345	334	326	318	308	298	287	275	249	218	172	
10SDR 40/12A 8SM	110	150		443	377	364	355	345	334	322	310	297	268	235	184	
10SDR B40/13A 8SM	132	180		485	420	408	399	389	378	365	351	335	301	264	220	
10SDR B40/14A 8SM	132	180		522	451	438	428	418	405	391	376	359	323	283	235	
10SDR B40/15A 8SM	150	200		563	474	460	450	439	426	413	398	382	346	306	251	
10SDR B40/16A 8SM	150	200		600	504	489	478	466	453	438	422	405	367	324	266	
10SDR B40/17A 8SM	165	220		638	537	521	510	497	483	468	451	433	392	346	284	
10SDR B40/18A 8SM	165	220		675	567	550	538	524	509	493	475	456	413	364	299	

P2: Rated motor power output.  
H: Total head in m

**Coverage chart n ≈ 2900 rpm**

Model	P2		Q = Flow													
			m³/h	0	144	160	170	180	190	200	220	240	260	280	300	324
			l/min		2400	2670	2830	3000	3170	3330	3670	4000	4330	4670	5000	5400
kW		HP		H (m) = Total head												
12SDS 42/4A 12SM	170	230		304	246	239	235	230	226	221	211	199	187	172	156	135
12SDS 42/4A 8SM	185	250		291	243	237	233	229	224	219	207	194	180	165	150	132
12SDS 42/5MN 12SM	190	260		342	285	278	273	267	262	256	243	228	210	191	170	145
12SDS 42/5A 12SM	220	300		378	309	300	295	289	282	276	262	247	230	211	192	166
12SDS 42/6P 12SM	250	340		426	349	339	333	326	320	312	297	280	260	238	213	180
12SDS 42/6B 12SM	250	340		399	336	328	323	316	310	302	286	267	245	222	197	165
12SDS 42/6A 12SM	250	340		452	365	355	348	342	335	328	313	296	277	255	231	198
12SDS 42/7M 12SM	300	400		501	411	400	392	384	376	367	348	327	304	278	250	214
12SDS 42/7A 12SM	300	400		527	426	414	407	399	391	382	363	343	319	293	264	227
12SDS 42/8Q 12SM	350	475		559	461	450	442	434	425	415	394	370	342	310	276	235
12SDS 42/8A 12SM	350	475		604	490	477	468	460	450	441	420	397	371	342	310	268
12SDS 42/9M 12SM	400	540		650	530	517	508	498	488	478	454	428	397	362	324	276

Model	P2		Q = Flow											
			m³/h	0	108	120	130	140	150	160	180	200	220	240
			l/min		1800	2000	2170	2330	2500	2670	3000	3330	3670	4000
kW		HP		H (m) = Total head										
12SDS 50/1D 6SM	15	20		36	29,7	28,8	27,9	27	25,9	24,6	21,9	18,6	15,1	11,2
12SDS 50/1B 6SM	18,5	25		41,5	33,9	33	32,2	31,4	30,4	29,3	26,7	23,7	20,1	16,1
12SDS 50/1A 6SM	22	30		43,8	37,6	36,9	36,2	35,4	34,5	33,5	31	28	24,6	20,4
12SDS 50/2EF 6SM	26	35		60	53,2	51,6	49,9	48	45,8	43,3	37,6	30,8	23,4	15,1
12SDS 50/2DE 6SM	30	40		68,9	58,5	57	55,5	53,7	51,6	49,1	43,4	36,8	29,6	21,7
12SDS 50/2DE 8SM	30	40		68,9	58,5	57	55,5	53,7	51,6	49,1	43,4	36,8	29,6	21,7
12SDS 50/2BC 6SM	37	50		80	66,9	65,1	63,4	61,5	59,5	57,2	52	45,9	39,1	31,7
12SDS 50/2BC 8SM	37	50		80	69,4	67,7	66,2	64,5	62,6	60,4	55,5	49,4	42,3	34,3
12SDS 50/2A 6SM	45	60		88,3	75,6	73,8	72,2	70,4	68,5	66,4	61,7	56	49,2	41,1
12SDS 50/2A 8SM	45	60		87	76,6	75,2	74	72,6	71	69,2	64,8	59,2	52	43,4
12SDS 50/3C 8SM	51	70		120	101	97,6	95,1	92,4	89,4	86,1	78,5	69,5	59	47
12SDS 50/3K 8SM	59	80		130	109	107	105	102	99,1	96,2	89,2	80,6	70,2	58,3
12SDS 50/3A 8SM	66	90		136	117	114	112	110	107	104	97,1	88,5	78,2	66,2
12SDS 50/4Z 8SM	75	100		166	140	137	134	130	127	122	112	99,9	86	69,9
12SDS 50/4A 8SM	92	125		183	156	153	150	147	144	140	130	118	104	88,5
12SDS 50/5BC 8SM	92	125		205	172	168	164	160	155	150	138	124	106	84
12SDS 50/5A 8SM	110	150		227	198	194	191	187	182	177	166	153	138	121
12SDS 50/6A 8SM	132	180		275	239	234	230	225	220	214	200	183	163	140
12SDS 50/7I 8SM	150	200		319	274	268	263	257	250	243	226	206	183	156
12SDS 50/8M 8SM	165	220		358	310	303	296	289	281	273	254	231	205	174
12SDS 50/8A 12SM	170	230		362	316	308	302	295	287	279	260	238	212	181
12SDS 50/8A 8SM	185	250		361	316	309	302	295	288	280	261	239	213	181
12SDS 50/9A 12SM	190	260		407	354	346	339	331	323	313	292	267	238	202
12SDS 50/10A 12SM	220	300		451	393	385	377	368	359	349	326	299	266	226
12SDS 50/11A 12SM	250	340		496	433	424	415	405	395	384	358	328	292	247
12SDS 50/12A 12SM	300	400		543	472	461	452	441	430	417	390	358	319	271

**P2:** Rated motor power output.  
**H:** Total head in m

### Coverage chart n ≈ 2900 rpm

Model	P2		Q = Flow												
			m³/h	H (m) = Total head											
			l/min	0	119	130	140	150	162	180	200	220	240	260	288
kW	HP		1980	2170	2330	2500	2700	3000	3330	3670	4000	4330	4800		
12SDS 55/1GH 6SM	15	20	29	24,5	24	23,6	23,1	22,5	21,4	20	18,4	16,5	14,5	-	
12SDS 55/1EF 6SM	18.5	25	33,7	28,2	27,7	27,3	26,9	26,4	25,5	24,4	22,9	21,1	19	15,7	
12SDS 55/1D 6SM	22	30	37	31,6	31,2	30,8	30,4	29,9	29,1	27,9	26,6	24,9	23	20,1	
12SDS 55/1B 6SM	30	40	42,7	36,8	36,3	35,9	35,5	35	34,1	33	31,6	30	28,2	-	
12SDS 55/1B 8SM	30	40	43,1	37,3	36,8	36,4	36	35,5	34,6	33,5	32,1	30,5	28,7	25,8	
12SDS 55/2GH 6SM	30	40	58,7	50,1	49,4	48,7	47,8	46,5	44,3	41,1	37,4	33,3	28,7	-	
12SDS 55/2GH 8SM	30	40	58,7	50,1	49,4	48,7	47,8	46,5	44,3	41,1	37,4	33,3	28,7	-	
12SDS 55/2EF 6SM	37	50	66,8	57,3	56,4	55,6	54,7	53,4	51,2	48,4	45	41,1	36,8	-	
12SDS 55/2EF 8SM	37	50	67,4	58,6	57,9	57,2	56,4	55,3	53,4	50,7	47,5	43,5	39,1	32,4	
12SDS 55/2D 6SM	45	60	74,2	65,8	64,9	64	63,1	61,9	59,8	57	53,9	50,2	46,1	39,4	
12SDS 55/2D 8SM	45	60	74,9	65,6	65,1	64,5	63,9	63	61,3	58,8	55,7	52	47,8	41,4	
12SDS 55/2B 8SM	51	70	87	75,5	74,4	73,4	72,4	71,1	68,9	66	62,8	59,1	54,9	48,3	
12SDS 55/2A 8SM	59	80	89,1	79	77,9	76,9	75,9	74,6	72,4	69,6	66,4	62,6	58,2	51,3	
12SDS 55/3DE 8SM	59	80	107	93,6	92,5	91,5	90,3	88,8	86	82,2	77,4	71,7	65,1	55	
12SDS 55/3CJ 8SM	66	90	114	100	99	98,2	97,2	95,8	93,2	89,5	84,8	79,3	73,1	63,4	
12SDS 55/3A 8SM	92	125	136	122	120	119	117	115	112	108	104	97,7	91,4	81	
12SDS 55/4JF 8SM	75	100	136	120	118	117	115	113	109	103	95,9	87,8	78,6	65,1	
12SDS 55/4D 8SM	92	125	150	135	133	131	129	127	123	118	112	105	96,3	81,9	
12SDS 55/4B 8SM	110	150	170	149	148	146	145	143	140	136	131	124	117	103	
12SDS 55/5T 8SM	132	180	208	185	183	181	179	177	173	167	161	153	143	128	
12SDS 55/5D 8SM	110	150	186	163	161	159	157	155	151	145	138	129	119	104	
12SDS 55/6BC 8SM	150	200	251	221	219	217	215	212	207	199	190	180	167	147	
12SDS 55/6A 8SM	165	220	279	240	237	234	231	227	220	213	204	193	180	158	
12SDS 55/7K 12SM	190	260	314	279	276	273	270	266	259	249	238	225	210	185	
12SDS 55/8A 12SM	220	300	371	323	318	314	310	304	296	285	272	257	240	213	
12SDS 55/9Q 12SM	250	340	401	352	347	342	338	332	322	309	295	279	261	231	
12SDS 55/9B 12SM	250	340	364	342	339	335	331	326	317	306	293	277	260	231	
12SDS 55/10A 12SM	300	400	466	403	397	392	387	380	370	356	341	323	301	266	

Model	P2		Q = Flow												
			m³/h	H (m) = Total head											
			l/min	0	180	220	240	260	280	300	320	340	360	385	400
kW	HP		3000	3670	4000	4330	4670	5000	5330	5670	6000	6420	6670	7200	
12SDS 58/1AB 6SM	37	50	45,7	35,5	34,2	33,5	32,7	31,7	30,4	28,9	27,1	24,9	22	-	-
12SDS 58/1AB 8SM	37	50	45,7	35,5	34,2	33,5	32,7	31,7	30,4	28,9	27,1	24,9	22	-	-
12SDS 58/2BC 8SM	59	80	81,4	64,9	61,6	59,8	57,8	55,5	52,7	49,5	45,8	41,7	36	-	-
12SDS 58/2AJ 8SM	66	90	85,9	70,1	67	65,3	63,5	61,3	58,7	55,7	52,1	48,1	42,8	-	-
12SDS 58/2A 8SM	75	100	91,7	76,3	73,2	71,6	69,7	67,6	65,3	62,5	59,3	55,8	50,7	47,3	39,6
12SDS 58/3W 8SM	92	125	124	103	97	94,3	91,5	88,3	84,7	80,4	75,2	69,2	60,2	-	-
12SDS 58/3A 8SM	110	150	137	114	109	106	102	98,4	94,4	90,2	85,6	80,7	74,1	69,8	59,8
12SDS 58/4M 8SM	132	180	174	145	139	135	131	127	122	116	110	102	91,1	84,3	69
12SDS 58/4A 8SM	150	200	183	158	153	150	146	142	137	131	124	117	107	99,6	84,4
12SDS 58/5M 12SM	170	230	220	187	179	174	169	164	158	151	143	134	121	113	95,1
12SDS 58/5M 8SM	185	250	219	183	174	169	163	157	151	144	136	128	117	109	92,1
12SDS 58/5I 8SM	185	250	227	191	182	178	172	167	160	153	145	137	125	117	99,8
12SDS 58/5A 12SM	190	260	230	199	192	188	184	178	172	165	157	148	135	127	107
12SDS 58/6Z 12SM	190	260	254	215	206	201	195	189	181	172	162	150	134	123	99,8
12SDS 58/7Z 12SM	250	340	298	255	244	238	231	223	214	203	192	179	160	148	119
12SDS 58/7X 12SM	250	340	305	261	250	243	235	226	216	205	193	180	161	150	121
12SDS 58/7A 12SM	300	400	321	276	266	260	253	245	237	228	217	205	187	176	148
12SDS 58/8AB 12SM	300	400	354	299	286	279	271	262	252	241	229	215	196	183	153

**P2:** Rated motor power output.  
**H:** Total head in m

### Coverage chart n ≈ 2900 rpm

Model	P2		Q = Flow																
			m³/h	H (m) = Total head															
			l/min	0	209	216	220	240	260	280	300	320	340	368	380	402	420	450	457
kW	HP	3480	3600	3670	4000	4330	4670	5000	5330	5670	6130	6330	6700	7000	7500	7620	7620		
14SDS 50/1E 8SM	30	40	44,7	32,3	31,8	31,6	30,2	28,8	27,3	25,6	23,9	22	19,4	-	-	-	-	-	
14SDS 50/1D 8SM	37	50	51,4	38,1	37,6	37,4	36,1	34,8	33,3	31,7	29,9	28	25,2	23,9	-	-	-	-	
14SDS 50/1C 8SM	45	60	58	43,7	43,3	43	41,7	40,4	39	37,5	35,8	33,9	30,9	29,6	27	-	-	-	
14SDS 50/1B 8SM	51	70	63,4	48,4	47,9	47,7	46,4	45	43,6	42,1	40,4	38,5	35,7	34,4	31,9	-	-	-	
14SDS 50/1A 8SM	59	80	68,6	52,9	52,5	52,2	50,9	49,5	48,1	46,5	44,9	43,1	40,4	39,2	36,8	-	-	-	
14SDS 50/2E 8SM	59	80	89	63,4	62,5	62	59,5	56,9	54	50,9	47,5	43,8	38,3	-	-	-	-	-	
14SDS 50/2D 8SM	66	90	102	74,9	74	73,5	71	68,3	65,5	62,3	58,8	54,9	49,1	46,5	-	-	-	-	
14SDS 50/2CD 8SM	75	100	108	80,9	80,1	79,6	77	74,4	71,6	68,4	64,9	61,1	55,2	52,5	-	-	-	-	
14SDS 50/2BC 8SM	92	125	122	93,2	92,3	91,8	89,2	86,5	83,8	80,8	77,5	73,8	68,1	65,5	60,4	-	-	-	
14SDS 50/2AB 8SM	110	150	133	104	103	103	99,5	96,9	94,1	91,1	88	84,5	79,1	76,6	71,7	67,5	60,2	-	
14SDS 50/3C 8SM	132	180	176	135	134	133	130	126	122	117	112	106	96,9	92,8	85,1	-	-	-	
14SDS 50/3B 8SM	150	200	196	151	150	149	145	141	137	133	128	123	115	111	103	-	-	-	
14SDS 50/3A 8SM	185	250	210	168	166	166	162	158	154	149	145	140	132	128	121	115	104	-	
14SDS 50/3A 12SM	170	230	210	168	166	166	162	158	154	149	144	139	131	127	120	114	104	-	
14SDS 50/4BC 8SM	185	250	248	192	190	189	184	179	173	167	161	154	143	138	128	119	104	-	
14SDS 50/4BC 12SM	190	260	248	192	190	189	184	178	172	166	159	152	141	136	126	118	104	-	
14SDS 50/4I 12SM	220	300	275	218	216	215	210	204	198	191	185	177	167	162	153	145	133	-	
14SDS 50/5JC 12SM	250	340	317	-	244	243	236	230	223	215	207	199	185	178	166	155	136	-	
14SDS 50/5I 12SM	300	400	345	-	270	268	262	255	248	240	232	224	211	205	193	183	165	-	
14SDS 50/6W 12SM	350	475	399	-	313	312	304	296	287	278	268	257	241	233	218	206	184	179	
14SDS 50/6I 12SM	350	475	414	-	326	325	317	309	301	292	282	272	256	249	235	223	201	196	
14SDS 50/7Q 12SM	400	540	461	-	358	356	347	337	327	317	305	293	275	266	249	235	210	-	

Model	P2		Q = Flow																
			m³/h	H (m) = Total head															
			l/min	0	216	250	270	290	300	320	340	360	380	400	420	450	457	500	540
kW	HP	3600	4170	4500	4830	5000	5330	5670	6000	6330	6670	7000	7500	7620	8330	9000	9900		
14SDS 55/1FG 8SM	37	50	38,9	-	-	30,4	29,5	29	27,9	26,7	25,4	23,9	22,3	20,6	17,8	-	-	-	-
14SDS 55/1EF 8SM	45	60	43,9	-	-	35,3	34,5	34,1	33,2	32,1	30,9	29,6	28,1	26,5	23,9	-	-	-	-
14SDS 55/1DE 8SM	51	70	49	-	-	40,5	39,8	39,4	38,6	37,6	36,6	35,4	34	32,5	30	-	-	-	-
14SDS 55/1CJ 8SM	59	80	53,6	-	-	44,7	43,9	43,5	42,7	41,8	40,7	39,6	38,4	37	34,8	34,3	-	-	-
14SDS 55/1C 8SM	66	90	57,9	-	-	48,9	48,1	47,7	46,9	45,9	45	43,9	42,7	41,5	39,6	39,1	36	33,1	-
14SDS 55/1B 8SM	75	100	64,7	-	-	53,4	52,5	52,1	51,2	50,3	49,4	48,3	47,2	46	44	43,5	40,3	36,9	-
14SDS 55/1A 8SM	92	125	72,6	-	-	59,6	58,6	58,1	57,1	56	54,9	53,8	52,6	51,3	49,3	48,8	45,4	41,8	35,9
14SDS 55/2JF 8SM	92	125	91,9	-	-	76,7	75,2	74,4	72,6	70,5	68,1	65,5	62,5	59,2	53,9	52,6	-	-	-
14SDS 55/2JE 8SM	110	150	103	-	-	87,4	86,1	85,4	83,8	82	79,9	77,5	74,9	72	67	65,7	57,4	-	-
14SDS 55/2JC 8SM	150	200	133	-	-	113	111	110	109	107	105	103	101	97,5	93,3	92,2	85,1	77,6	-
14SDS 55/2C 8SM	132	180	119	-	-	104	102	102	99,9	98,4	96,7	94,7	92,4	89,8	85,3	84,2	76,4	68,5	-
14SDS 55/2AB 8SM	185	250	142	-	-	120	118	117	116	114	112	110	107	105	101	99,5	92,8	85,7	75,1
14SDS 55/2AB 12SM	170	230	142	-	-	121	119	118	116	114	112	110	108	105	101	99,7	92,8	85,6	75,2
14SDS 55/3D 8SM	185	250	161	-	-	138	137	136	133	131	128	125	121	118	111	109	97,1	-	-
14SDS 55/3D 12SM	170	230	161	-	-	139	137	136	134	132	129	125	121	117	109	107	95,9	-	-
14SDS 55/3JD 12SM	190	260	173	-	-	150	148	147	145	143	140	137	133	129	122	120	109	96,8	-
14SDS 55/3BC 12SM	220	300	197	-	-	164	162	160	158	155	152	149	145	142	135	134	123	111	93,4
14SDS 55/3B 12SM	250	340	206	-	-	175	172	171	169	166	163	160	156	152	146	144	133	122	106
14SDS 55/3A 12SM	300	400	220	-	-	184	181	180	177	174	172	168	165	161	155	154	144	133	117
14SDS E55/4BJ 12SM	300	400	248	-	-	213	210	209	206	203	199	195	190	185	177	175	160	145	121
14SDS E55/4I 12SM	350	475	288	249	244	241	238	236	233	229	226	221	217	212	203	201	188	174	-
14SDS E55/4B 12SM	350	475	275	-	-	233	229	228	224	220	216	212	207	202	194	192	179	165	143
14SDS E55/5C 12SM	350	475	298	-	-	259	256	254	251	247	242	237	232	226	215	213	195	176	146
14SDS E55/5BC 12SM	400	540	320	-	-	274	270	268	264	260	255	249	243	237	227	224	207	189	160

**P2:** Rated motor power output.

**H:** Total head in m

**Coverage chart n ≈ 2900 rpm**

Model	P2		Q = Flow														
			m³/h	0	432	450	500	550	600	650	676	720	738	760	810	840	
					7200	7500	8330	9170	10000	10800	11300	12000	12300	12700	13500	14000	
kW		HP		H (m) = Total head													
14SDS 64/1L 8SM	51	70	42,5	26,2	25,6	23,8	21,3	17,7	-	-	-	-	-	-	-	-	
14SDS 64/1H 8SM	59	80	46,6	31,4	30,8	28,8	26,3	23	-	-	-	-	-	-	-	-	
14SDS 64/1G 8SM	66	90	51,1	-	-	-	30,7	27,6	23,6	21,1	-	-	-	-	-	-	
14SDS 64/1F 8SM	75	100	55,5	-	-	-	34,9	31,8	27,9	25,6	21,7	-	-	-	-	-	
14SDS 64/1D 8SM	92	125	64,4	-	-	-	41,4	38,8	35,4	33,3	29,3	27,6	25,5	-	-	-	
14SDS 64/1B 8SM	110	150	73,8	-	-	-	46,8	44,8	42,3	40,6	37,3	35,8	33,8	29	-	-	
14SDS 64/1A 8SM	132	180	82,1	-	-	-	51,7	50,2	48,2	46,9	43,9	42,4	40,5	35,5	32,5	-	
14SDS 64/2G 8SM	132	180	102	-	-	-	63	56,8	48,9	44,2	35,7	-	-	-	-	-	
14SDS 64/2EF 8SM	150	200	115	-	-	-	73,6	67,8	60,6	56,4	48,6	45,4	-	-	-	-	
14SDS 64/2DE 8SM	185	250	125	-	-	-	75,8	70,7	64,3	60,4	52,6	49,1	44,5	-	-	-	
14SDS 64/2DE 12SM	170	230	124	-	-	-	81,7	76	69,1	65	57,4	54	49,9	-	-	-	
14SDS 64/2C 12SM	190	260	138	-	-	-	91,3	85,8	79,3	75,4	68,2	65,1	61,2	52,6	-	-	
14SDS 64/2A 12SM	220	300	159	-	-	-	103	97,4	91,3	87,7	81,2	78,3	74,6	66	60,9	-	
14SDS 64/3JF 12SM	250	340	174	-	-	-	113	105	94,2	88,3	77,4	72,7	66,7	-	-	-	
14SDS 64/3JD 12SM	300	400	201	-	-	-	134	125	114	108	95,8	90,8	84,4	69,5	-	-	
14SDS 64/3B 12SM	350	475	222	163	161	154	147	139	129	124	113	109	103	87,7	-	-	
14SDS 64/3A 12SM	350	475	238	175	173	165	157	149	139	134	124	119	113	99,4	91,2	-	
14SDS 64/4CD 12SM	400	540	264	-	-	-	174	163	150	143	129	123	115	-	-	-	

Model	P2		Q = Flow														
			m³/h	0	478	500	521	550	600	650	676	720	738	760	810	840	900
					7970	8330	8680	9170	10000	10800	11300	12000	12300	12700	13500	14000	15000
kW		HP		H (m) = Total head													
18SDS 64/1L 8SM	51	70	42	25,8	25,1	24,3	23,2	21	18	16	-	-	-	-	-	-	
18SDS 64/1H 8SM	59	80	46	31,7	30,9	30	28,7	25,8	22,3	20,3	17	-	-	-	-	-	
18SDS 64/1G 8SM	66	90	50,2	-	-	34,9	33,5	30,5	26,7	24,6	21,3	-	-	-	-	-	
18SDS 64/1F 8SM	75	100	54	-	-	38,9	37,5	34,7	31,4	29,4	25,8	24,2	-	-	-	-	
18SDS 64/1D 8SM	92	125	61,5	-	-	46,2	44,9	42,3	39,2	37,4	34	32,6	30,8	26,8	-	-	
18SDS 64/1B 8SM	110	150	70,8	-	-	52,7	51,6	49,5	46,9	45,2	41,9	40,4	38,5	34,1	-	-	
18SDS 64/1A 8SM	132	180	77,5	-	-	57,8	56,8	54,9	52,5	51	48,2	46,9	45,2	40,8	37,9	32	
18SDS 64/2G 8SM	132	180	101	-	-	70,9	68,3	62,5	55,2	50,8	42,9	-	-	-	-	-	
18SDS 64/2EF 8SM	150	200	112	-	-	83,1	80,4	74,6	67,7	63,6	56,3	53,2	49,4	-	-	-	
18SDS 64/2DE 8SM	185	250	120	-	-	89,7	87	81,4	74,4	70,2	62,5	59,2	55,1	46,3	-	-	
18SDS 64/2DE 12SM	170	230	120	-	-	91,6	89,3	84,3	77,7	73,6	65,8	62,3	58,1	49,1	-	-	
18SDS 64/2C 12SM	190	260	133	-	-	101	98,1	93,3	87,3	83,7	76,8	73,8	70	61,2	-	-	
18SDS 64/2A 12SM	220	300	154	-	-	114	112	107	101	97,6	91,5	88,7	85,2	76,4	70,6	58,2	
18SDS 64/3JF 12SM	250	340	170	-	-	127	123	114	104	97,7	87,1	82,6	76,8	63,3	55	38	
18SDS 64/3B 12SM	350	475	213	-	-	159	156	149	141	136	126	122	116	102	93,2	77,4	
18SDS 64/3A 12SM	350	475	230	-	-	172	168	161	153	148	138	134	128	114	105	85,5	
18SDS 64/4CD 12SM	400	540	255	-	-	194	188	177	164	157	144	138	131	115	105	84,8	

**P2:** Rated motor power output.  
**H:** Total head in m

**Coverage chart n ≈ 2900 rpm**

Model			Q = Flow																
			m³/h	H (m) = Total head															
			l/min	0	3,6	4	5	6	7	8	9	10	11	12	13	14	15	16,1	
	P2			60	66.7	83.3	100	117	133	150	167	183	200	217	233	250	268		
	kW	HP																	
I-6SDR 30/9A 6SM	4	5,5	133	127	125	122	118	113	108	103	96,8	90,3	83,3	75,6	67,2	57,9	46,1		
I-6SDR 30/13A 6SM	5.5	7.5	190	181	179	173	167	159	152	144	136	127	117	107	94,9	81,6	64,2		
I-6SDR 30/18A 6SM	7.5	10	264	251	248	240	231	222	212	200	188	174	160	145	129	111	88,1		
I-6SDR 30/22A 6SM	9,2	12,5	322	307	303	294	283	271	258	244	229	213	196	178	159	137	109		
I-6SDR 30/26A 6SM	11	15	381	363	359	348	336	322	308	292	275	257	237	215	191	164	129		
I-6SDR 30/31A 6SM	13	17,5	453	429	424	411	396	381	364	345	324	302	278	252	224	193	153		
I-6SDR 30/36A 6SM	15	20	527	503	498	482	465	446	425	402	378	352	323	292	257	218	169		
I-6SDR 30/40A 6SM	18,5	25	584	555	549	532	513	493	470	445	419	391	361	328	292	251	198		
I-6SDR 30/45A 6SM	18,5	25	653	618	612	593	573	551	526	499	469	437	401	363	322	276	216		
I-6SDR 30/49A 6SM	22	30	715	678	670	650	628	603	576	547	514	479	441	400	355	305	240		
I-6SDR 30/53A 6SM	22	30	771	729	721	698	674	647	618	586	551	513	471	427	378	323	253		
I-6SDR 30/56A 6SM	26	35	820	779	771	747	722	694	663	630	593	554	511	463	411	351	276		
I-6SDR 30/60A 6SM	26	35	876	828	819	794	767	737	705	670	631	589	543	493	438	376	296		

Model			Q = Flow																
			m³/h	H (m) = Total head															
			l/min	0	7,2	8	9	10	11	12	13	14	15	16	17	18	19	20	21,6
	P2			120	133	150	167	183	200	217	233	250	267	283	300	317	333	360	
	kW	HP																	
I-6SDR 37/7A 6SM	4	5,5	104	95,4	93,6	91,2	88,7	86	83,2	80,2	77,1	73,8	70,2	66,5	62,5	58,2	53,5	45,2	
I-6SDR 37/9A 6SM	5.5	7.5	134	123	121	118	115	112	108	104	101	96,1	91,7	86,9	81,8	76,1	69,9	58,5	
I-6SDR 37/11A 6SM	7.5	10	165	153	150	147	143	139	135	131	126	121	115	109	103	95,1	87,3	73,2	
I-6SDR 37/13A 6SM	7.5	10	194	178	174	170	165	160	154	148	143	136	130	123	116	108	98,7	83,3	
I-6SDR 37/16A 6SM	9,2	12,5	237	217	213	208	202	196	190	183	176	168	160	151	141	131	120	101	
I-6SDR 37/19A 6SM	11	15	282	259	255	248	241	234	227	218	210	201	191	181	170	158	145	121	
I-6SDR 37/22A 6SM	13	17,5	326	300	295	288	281	273	265	256	246	236	225	212	199	185	169	141	
I-6SDR 37/26A 6SM	15	20	386	354	348	339	329	319	308	298	286	274	261	247	232	216	198	166	
I-6SDR 37/29A 6SM	18,5	25	429	396	389	380	371	360	349	337	324	310	295	279	262	243	223	187	
I-6SDR 37/32A 6SM	18,5	25	472	434	426	415	403	391	378	365	351	336	320	303	284	263	241	200	
I-6SDR 37/35A 6SM	22	30	518	474	466	455	443	431	418	404	388	372	355	336	316	293	269	225	
I-6SDR 37/38A 6SM	22	30	561	513	503	491	478	464	450	435	419	401	383	362	339	314	286	237	
I-6SDR 37/41A 6SM	26	35	609	559	549	535	521	506	490	474	457	438	418	397	373	347	318	266	
I-6SDR 37/45A 6SM	26	35	666	611	600	584	568	550	532	512	492	470	448	424	399	371	342	287	
I-6SDR 37/48A 6SM	30	40	711	651	639	624	607	590	572	552	532	510	486	460	431	399	364	302	
I-6SDR 37/52A 6SM	30	40	766	698	686	669	652	633	614	593	570	546	520	492	461	428	392	327	
I-6SDR 37/56A 6SM	37	50	829	755	741	722	703	684	663	642	619	594	567	537	504	467	426	351	
I-6SDR 37/60A 6SM	37	50	884	806	791	772	753	732	710	686	661	633	603	570	533	493	450	372	

Model			Q = Flow																
			m³/h	H (m) = Total head															
			l/min	0	10,8	12	13	14	16	18	20	22	24	26	28	30	32	34	
	P2			180	200	217	233	267	300	333	367	400	433	467	500	533	567		
	kW	HP																	
I-6SDR 47/4I 6SM	4	5,5	58,4	55,3	54,9	54,6	54,2	53,3	52,1	50,6	48,8	46,6	44,1	41,2	38,1	34,8	31,2		
I-6SDR 47/5A 6SM	5.5	7.5	75,8	71,5	70,9	70,4	69,8	68,5	67	65,1	62,9	60,2	57,2	53,8	49,9	45,7	41,1		
I-6SDR 47/7A 6SM	7.5	10	107	101	101	99,6	98,8	97	94,8	92,2	88,9	85,2	80,8	75,8	70,3	64,3	57,7		
I-6SDR 47/9I 6SM	9,2	12,5	134	127	126	125	124	122	119	116	112	107	101	94,6	87,6	80,1	71,9		
I-6SDR 47/10A 6SM	11	15	152	145	144	143	142	139	136	131	127	121	115	108	99,6	91,2	82,3		
I-6SDR 47/12A 6SM	13	17,5	182	173	172	170	169	166	161	157	151	144	137	129	120	110	98,9		
I-6SDR 47/14A 6SM	15	20	212	200	198	197	195	191	186	181	174	167	158	148	137	126	113		
I-6SDR 47/17A 6SM	18,5	25	257	244	242	240	238	234	227	220	212	202	191	179	166	152	137		
I-6SDR 47/21A 6SM	22	30	317	299	297	295	292	286	278	268	258	245	232	217	201	185	167		
I-6SDR 47/25A 6SM	26	35	378	356	353	350	347	339	330	319	306	291	275	258	239	218	196		
I-6SDR 47/28A 6SM	30	40	422	398	395	392	388	381	372	361	348	333	315	295	273	249	223		
I-6SDR 47/31A 6SM	37	50	467	-	-	432	429	421	411	399	384	367	347	325	300	273	244		
I-6SDR 47/35A 6SM	37	50	526	-	-	491	487	478	467	452	434	412	387	360	330	299	266		

**P2:** Rated motor power output.  
**H:** Total head in m

### Coverage chart n ≈ 2900 rpm

Model			Q = Flow																
			m³/h	H (m) = Total head															
			l/min	0	14,4	16	18	20	22	24	26	28	30	32	34	36	38	40	44
	P2			240	267	300	333	367	400	433	467	500	533	567	600	633	667	733	800
	kW	HP																	
I-6SDS 50/3A 6SM	4	5,5	43,1	41,4	41	40,5	39,9	39,2	38,4	37,5	36,5	35,4	34,2	32,8	31,4	29,8	28,2	24,3	19,4
I-6SDS 50/4A 6SM	5.5	7.5	57,2	54,5	54	53,3	52,6	51,8	50,8	49,7	48,5	47,2	45,7	44	42,1	40	37,8	32,6	26,6
I-6SDS 50/6M 6SM	7.5	10	79,6	75	74,3	73,4	72,3	71,1	69,8	68,3	66,6	64,7	62,6	60,2	57,5	54,4	51,1	43,4	34,5
I-6SDS 50/7I 6SM	9,2	12,5	94,6	89,8	89,2	88,3	87,3	86,2	85	83,5	81,8	79,8	77,5	74,8	71,6	68,1	64,1	54,8	44,3
I-6SDS 50/8A 6SM	11	15	114	110	109	107	106	105	103	101	98	95,3	92,3	88,9	85,2	81	76,4	66	53,8
I-6SDS 50/9A 6SM	13	17,5	129	123	122	120	119	117	115	113	111	108	104	101	96	91,3	86,2	74,5	60,8
I-6SDS 50/11A 6SM	15	20	157	150	149	147	146	144	141	138	135	131	127	122	117	111	105	90,3	73,6
I-6SDS 50/14A 6SM	18,5	25	199	188	186	184	182	179	176	172	168	163	157	151	144	137	129	111	89,6
I-6SDS 50/16A 6SM	22	30	228	216	215	212	210	207	203	199	194	188	182	175	167	159	150	129	105
I-6SDS 50/19A 6SM	26	35	271	258	256	253	250	246	242	237	231	225	218	209	200	191	180	154	125
I-6SDS 50/22A 6SM	30	40	313	298	296	293	289	284	279	273	266	259	250	240	230	218	206	177	144
I-6SDS 50/28A 6SM	37	50	397	376	373	369	363	358	351	343	335	325	314	302	288	273	257	220	177

Model			Q = Flow											
			m³/h	H (m) = Total head										
			l/min	0	18	20	22	24	26	30	35	40	45	50
	P2			300	333	367	400	433	500	583	667	750	833	900
	kW	HP												
I-6SDS 55/2I 6SM	4	5,5	31,8	30,2	29,9	29,7	29,4	29,2	28,5	27,3	25,8	23,8	21,4	19,2
I-6SDS 55/3P 6SM	5.5	7.5	46,1	43,6	43,2	42,8	42,4	41,9	40,7	38,7	36,1	32,9	29,2	25,7
I-6SDS 55/4P 6SM	7.5	10	62,7	59,3	58,8	58,3	57,7	57,1	55,5	52,9	49,7	45,6	40,6	36,1
I-6SDS 55/5Q 6SM	9,2	12,5	77	72,6	72,1	71,5	70,8	70,1	68,3	65,1	60,9	55,7	49,4	43,7
I-6SDS 55/6Z 6SM	11	15	92,5	87	86,4	85,7	84,9	84	81,8	78	73	66,6	59	52
I-6SDS 55/7Z 6SM	13	17,5	109	103	102	101	99,6	98,4	95,6	91,2	85,7	78,7	70,1	62,1
I-6SDS 55/8S 6SM	15	20	125	118	118	117	116	114	111	106	99	90,7	80,8	71,9
I-6SDS 55/9A 6SM	18,5	25	147	140	139	138	136	135	132	126	120	111	99,7	89,8
I-6SDS 55/11M 6SM	22	30	177	167	166	165	163	161	157	151	142	131	118	105
I-6SDS 55/13M 6SM	26	35	210	198	196	195	193	191	186	178	168	156	140	126
I-6SDS 55/15M 6SM	30	40	242	229	227	225	223	220	215	206	194	180	162	145
I-6SDS 55/18A 6SM	37	50	294	277	275	273	271	268	262	251	237	219	198	177
I-6SDS 55/21A 6SM	45	60	342	325	322	319	316	313	305	292	276	255	230	206

Model			Q = Flow												
			m³/h	H (m) = Total head											
			l/min	0	28,8	30	35	40	45	50	55	60	65	70	75
	P2			480	500	583	667	750	833	917	1000	1080	1170	1250	1350
	kW	HP													
I-6SDS 64/2I 6SM	4	5,5	27,6	25	24,9	24,3	23,6	22,7	21,6	20,2	18,7	16,9	14,9	12,6	9,7
I-6SDS 64/3K 6SM	5.5	7.5	40,1	36,1	35,9	35	33,9	32,6	30,9	28,9	26,5	23,8	20,8	17,4	13,1
I-6SDS 64/4K 6SM	7.5	10	55,1	49,6	49,3	47,9	46,3	44,3	42,1	39,5	36,5	33,1	29,2	24,9	19,1
I-6SDS 64/5M 6SM	9,2	12,5	67,5	61	60,6	59,1	57,2	54,8	51,9	48,3	44,1	39,4	34,2	28,6	21,9
I-6SDS 64/6M 6SM	11	15	82,3	73,1	72,5	70	67,2	64,2	61	57,3	53,1	48,1	42,3	35,8	27,5
I-6SDS 64/7MN 6SM	13	17,5	94,8	85,5	85	82,8	80,1	76,9	73	68,3	62,9	56,6	49,6	41,9	31,8
I-6SDS 64/7A 6SM	15	20	103	94,1	93,5	90,8	87,8	84,4	80,6	76,2	71	64,8	57,6	49,7	39,9
I-6SDS 64/9A 6SM	18,5	25	132	120	119	115	112	107	102	96,1	89,3	81,3	72,2	62,2	49,8
I-6SDS 64/11K 6SM	22	30	157	143	142	138	133	127	121	114	106	95,8	85,3	73,5	57,8
I-6SDS 64/13K 6SM	26	35	186	168	167	163	158	152	145	136	126	114	101	86,6	68,9
I-6SDS 64/15K 6SM	30	40	215	193	192	187	181	175	167	157	145	132	116	99,1	78,4
I-6SDS 64/18A 6SM	37	50	262	235	233	228	221	213	203	191	177	161	143	123	98,5
I-6SDS 64/21A 6SM	45	60	307	276	274	266	257	247	236	223	208	190	168	145	115

**P2:** Rated motor power output.

**H:** Total head in m

### Coverage chart n ≈ 2900 rpm

Model	P2		Q = Flow																
			m³/h	0	28,8	35	40	45	50	55	60	65	70	75	80	85	90	96	
					l/min	480	583	667	750	833	917	1000	1080	1170	1250	1330	1420	1500	1600
kW		HP		H (m) = Total head															
I-8SDS 65/1D 6SM	4	5,5		24,9	22,7	22,2	21,8	21,2	20,4	19,6	18,6	17,4	16,2	14,8	13,4	11,8	10,2	8	
I-8SDS 65/1A 6SM	5,5	7,5		29,4	26,8	26,3	25,9	25,3	24,7	24	23,2	22,2	21,1	19,9	18,5	17,1	15,5	13,3	
I-8SDS 65/2T 6SM	7,5	10		47,5	43,3	42,2	41,2	39,9	38,4	36,7	34,7	32,5	30	27,3	24,4	21,2	17,5	12,1	
I-8SDS 65/2C 6SM	9,2	12,5		54,3	49,5	48,5	47,6	46,4	45,1	43,5	41,7	39,5	37,1	34,5	31,6	28,5	25,1	20,6	
I-8SDS 65/2A 6SM	11	15		58,7	53,5	52,5	51,7	50,7	49,5	48,1	46,5	44,6	42,5	40	37,4	34,4	31,2	26,9	
I-8SDS 65/3E 6SM	11	15		67,7	62,5	61,1	59,7	57,9	55,7	53,1	50,1	46,6	42,7	38,4	33,8	28,7	23,2	15,9	
I-8SDS 65/3JD 6SM	13	17,5		78,6	71,9	70,2	68,7	67	65	62,6	59,9	56,7	53,1	49,1	44,6	39,6	34,1	26,8	
I-8SDS 65/3K 6SM	15	20		84,9	78,1	76,4	75	73,3	71,4	69,2	66,6	63,7	60,4	56,7	52,6	48,1	43,3	37,2	
I-8SDS 65/4JC 6SM	18,5	25		110	101	98,4	96,3	94,1	91,5	88,5	85	81	76,5	71,4	65,7	59,6	53	44,7	
I-8SDS 65/4A 6SM	22	30		117	108	105	103	101	98	95,2	91,9	88,2	83,9	78,9	73,4	67,2	60,4	51,8	
I-8SDS 65/5KC 6SM	22	30		132	122	120	118	115	111	107	103	96,5	90,4	83,5	76,1	67,9	58,8	46,2	
I-8SDS 65/5A 6SM	26	35		146	134	132	130	127	124	121	117	112	106	99,4	92,3	84,5	76,1	65,3	
I-8SDS 65/6U 6SM	30	40		170	156	152	149	146	143	139	134	128	122	114	105	94,5	83,7	70,2	
I-8SDS 65/6U 8SM	30	40		171	158	155	152	149	146	141	136	130	123	116	107	97,2	87,1	74	
I-8SDS 65/6C 6SM	30	40		162	149	146	144	141	137	133	128	121	114	106	96	86,1	75,4	61,7	
I-8SDS 65/6C 8SM	30	40		163	151	148	146	143	139	135	129	123	116	108	98,8	89,3	78,9	65,4	
I-8SDS 65/7A 6SM	37	50		204	187	183	180	176	172	167	161	154	147	138	128	118	106	90,2	
I-8SDS 65/7A 8SM	37	50		205	189	186	183	179	176	171	166	159	152	143	133	122	110	94	
I-8SDS 65/9T 6SM	45	60		250	230	225	220	215	210	203	195	186	176	164	151	136	118	93,3	
I-8SDS 65/9T 8SM	45	60		253	234	230	226	222	217	210	202	193	183	172	158	144	127	103	
I-8SDS 65/10Z 8SM	51	70		287	265	260	256	251	245	238	230	220	208	195	181	165	148	126	
I-8SDS 65/11A 8SM	59	80		324	298	293	289	283	277	270	262	252	240	227	211	194	175	150	
I-8SDS 65/12A 8SM	66	90		353	325	319	314	309	302	294	285	274	261	247	230	211	190	164	
I-8SDS 65/14A 8SM	75	100		411	377	370	364	358	350	341	331	318	303	286	266	244	219	188	
I-8SDS 65/16A 8SM	92	125		470	432	424	417	410	401	391	379	365	348	329	306	280	252	216	
I-8SDS 65/17A 8SM	92	125		498	458	449	442	434	425	414	401	386	368	347	323	295	265	227	

Model	P2		Q = Flow														
			m³/h	0	54	60	65	70	75	80	85	90	95	100	110	120	132
					l/min	900	1000	1080	1170	1250	1330	1420	1500	1580	1670	1830	2000
kW		HP		H (m) = Total head													
I-8SDS 95/1C 6SM	7,5	10		27,4	25,1	24,7	24,3	23,9	23,4	22,9	22,3	21,6	20,9	20,1	18,3	16,2	13,3
I-8SDS 95/1A 6SM	9,2	12,5		30	27,1	26,8	26,6	26,4	26	25,7	25,2	24,7	24,1	23,4	21,7	19,6	16,6
I-8SDS 95/2F 6SM	9,2	12,5		38,2	34,9	33,8	32,7	31,5	30,2	28,7	27,1	25,3	23,4	21,3	16,6	-	-
I-8SDS 95/2DF 6SM	11	15		44,4	40,9	40,1	39,2	38,1	36,9	35,5	33,9	32,3	30,4	28,5	24	-	-
I-8SDS 95/2D 6SM	13	17,5		50,6	46,8	46,1	45,4	44,5	43,4	42,2	40,7	39,1	37,4	35,4	31	26,1	19,2
I-8SDS 95/2C 6SM	15	20		54,8	50,6	49,8	49	48,1	47,2	46,1	44,8	43,5	42,1	40,5	36,9	32,8	26,8
I-8SDS 95/2A 6SM	18,5	25		59,8	54,3	53,7	53,1	52,5	51,7	50,9	49,9	48,8	47,5	46,1	42,7	38,7	32,9
I-8SDS 95/3DJ 6SM	18,5	25		71,7	66,9	65,8	64,6	63,2	61,5	59,5	57,3	54,9	52,2	49,3	42,9	35,8	25,7
I-8SDS 95/3C 6SM	22	30		82	75,7	74,5	73,3	72,1	70,6	69	67,3	65,3	63,1	60,6	54,9	48,1	38,9
I-8SDS 95/3A 6SM	26	35		89,8	82,4	81,5	80,6	79,5	78,3	76,9	75,3	73,6	71,6	69,5	64,5	58,7	50,1
I-8SDS 95/4D 6SM	26	35		101	94,2	92,6	90,9	89	86,7	84,1	81,2	78	74,5	70,7	62,3	52,7	39,2
I-8SDS 95/4C 6SM	30	40		109	102	99,6	98	96,3	94,3	92,1	89,6	86,9	84	80,7	73,4	64,9	52,8
I-8SDS 95/4C 8SM	30	40		110	102	101	98,9	97,3	95,4	93,3	90,9	88,2	85,2	82	74,6	66	53,9
I-8SDS 95/4A 6SM	37	50		119	110	109	107	106	105	103	101	98	95,3	92,3	85,2	76,8	64,9
I-8SDS 95/4A 8SM	37	50		120	112	110	109	108	107	105	103	101	97,8	94,9	88,2	80,1	68,6
I-8SDS 95/5KC 6SM	37	50		134	125	123	121	118	116	113	110	106	102	97,7	88	76,7	60,4
I-8SDS 95/5KC 8SM	37	50		135	127	125	123	121	119	116	113	109	105	101	91,2	80,2	63,9
I-8SDS 95/5A 6SM	45	60		149	137	136	134	132	130	128	125	122	119	115	106	95,2	80,7
I-8SDS 95/5A 8SM	45	60		150	139	137	136	135	133	131	128	126	122	119	111	101	85,6
I-8SDS 95/6QC 6SM	45	60		161	150	148	146	143	140	136	132	127	122	117	106	92	72,6
I-8SDS 95/6QC 8SM	45	60		163	151	149	147	145	142	139	136	132	127	122	111	96,7	77,4
I-8SDS 95/7ZC 8SM	51	70		186	174	172	169	166	163	159	154	149	144	138	124	109	84,9
I-8SDS 95/7Z 8SM	59	80		203	188	186	184	182	179	176	172	168	163	158	146	131	111
I-8SDS 95/8Z 8SM	66	90		233	215	212	210	207	204	201	197	192	187	181	167	150	126
I-8SDS 95/10XC 8SM	75	100		273	254	250	246	242	237	232	226	219	212	204	185	163	131
I-8SDS 95/10A 8SM	92	125		300	277	274	271	268	265	260	256	250	244	237	220	199	170
I-8SDS 95/12C 8SM	92	125		329	308	304	300	295	289	282	275	266	257	247	225	200	165

**P2:** Rated motor power output.

**H:** Total head in m

**Coverage chart n ≈ 2900 rpm**

Model	P2		Q = Flow												
			m <sup>3</sup> /h	0	72	80	90	100	110	120	130	140	150	160	168
			l/min	1200	1330	1500	1670	1830	2000	2170	2330	2500	2670	2800	
kW		HP	H (m) = Total head												
I-8SDS 135/1F 6SM	5.5	7.5	20,4	17,1	16,6	15,8	14,9	13,8	12,6	11,4	10,1	8,8	7,3	6	
I-8SDS 135/1D 6SM	7.5	10	24,5	21,2	20,8	20,1	19,3	18,4	17,4	16,3	15,2	14	12,7	11,6	
I-8SDS 135/1B 6SM	9,2	12,5	27,2	23,9	23,4	22,8	22,1	21,2	20,2	19	17,8	16,5	15,1	14,1	
I-8SDS 135/2G 6SM	9,2	12,5	36,9	30,1	29	27,3	25,4	23,2	20,7	18,1	15,3	12,5	9,6	7,3	
I-8SDS 135/2F 6SM	11	15	40,8	34,3	33,2	31,7	29,8	27,8	25,5	23,2	20,7	18	14,9	11,9	
I-8SDS 135/2E 6SM	13	17,5	44,9	38,3	37,3	35,9	34,3	32,4	30,3	28	25,5	22,9	20,2	18	
I-8SDS 135/2D 6SM	15	20	48,9	42	41,1	39,7	38,2	36,4	34,4	32,3	29,9	27,4	24,9	22,7	
I-8SDS 135/2B 6SM	18,5	25	54,1	47,2	46,4	45,1	43,5	41,8	39,7	37,4	34,9	32,3	29,7	27,5	
I-8SDS 135/3E 6SM	18,5	25	66,9	56,9	55,5	53,5	51,1	48,3	45,1	41,6	37,7	33,7	29,5	26,3	
I-8SDS 135/3D 6SM	22	30	73	62,5	61	59,1	56,8	54,3	51,5	48,3	44,7	40,9	36,8	33,4	
I-8SDS 135/3B 6SM	26	35	81,2	70,5	69,1	67,2	65	62,5	59,5	56,2	52,5	48,5	44,4	41,1	
I-8SDS 135/4D 6SM	30	40	97,4	83,4	81,5	78,8	75,9	72,5	68,7	64,4	59,7	54,6	49,1	44,6	
I-8SDS 135/4D 8SM	30	40	97,9	84,6	82,7	80	76,9	73,4	69,6	65,3	60,8	55,9	50,5	45,8	
I-8SDS 135/4C 6SM	37	50	105	91,4	89,5	86,8	83,8	80,3	76,4	72,2	67,6	62,7	57,3	52,3	
I-8SDS 135/4C 8SM	37	50	106	93,1	91,4	88,8	85,7	82,2	78,3	74,1	69,6	64,8	59,5	54,6	
I-8SDS 135/5D 6SM	37	50	121	105	102	98,5	94,7	90,3	85,3	79,8	73,8	67,4	60,6	55	
I-8SDS 135/5D 8SM	37	50	123	106	104	101	96,3	92,1	87,4	82,3	76,6	70,5	63,8	57,9	
I-8SDS 135/5B 6SM	45	60	135	117	115	111	108	103	97,8	92,3	86,1	79,5	72,5	66,8	
I-8SDS 135/5B 8SM	45	60	136	120	117	114	111	107	102	95,9	89,4	82,4	75,4	70,1	
I-8SDS 135/6C 8SM	51	70	159	139	137	133	129	123	117	111	104	96,4	88,3	81	
I-8SDS 135/7C 8SM	59	80	186	163	160	155	150	143	137	129	122	114	104	95,2	
I-8SDS 135/7A 8SM	66	90	197	173	170	166	161	155	148	140	132	122	112	104	
I-8SDS 135/8C 8SM	66	90	212	186	183	178	172	165	157	148	138	128	117	107	
I-8SDS 135/8A 8SM	75	100	224	198	194	189	183	176	168	159	150	139	128	119	
I-8SDS 135/9C 8SM	75	100	238	208	204	198	191	183	175	165	155	143	131	120	
I-8SDS 135/10C 8SM	92	125	265	232	228	221	213	205	195	185	173	161	147	135	
I-8SDS 135/11C 8SM	92	125	290	254	249	242	234	224	214	202	190	176	161	148	

**P2:** Rated motor power output.  
**H:** Total head in m

**Coverage chart n ≈ 2900 rpm**

Model	P2		Q = Flow												
			m³/h l/min	0	90	100	120	140	160	180	192	198	200	220	240
					1500	1670	2000	2330	2670	3000	3200	3300	3330	3670	4000
kW	HP	H (m) = Total head													
I-10SDS 200/1F 6SM	11	15	27,8	24	23,4	21,7	19,3	16	11,5	-	-	-	-	-	
I-10SDS 200/1E 6SM	13	17,5	29,1	26,3	25,8	24,4	22,5	19,9	16,4	13,8	12,3	-	-	-	
I-10SDS 200/1DE 6SM	15	20	31,3	28,6	28	26,8	25	22,7	19,5	17,1	15,8	15,3	-	-	
I-10SDS 200/1D 6SM	18,5	25	33,6	30,7	30,1	28,7	27	25	22,3	20,2	19,1	18,7	14,2	-	
I-10SDS 200/1C 6SM	22	30	39	35,6	35,2	34,1	32,8	31	28,6	26,9	25,9	25,5	21,7	17	
I-10SDS 200/1B 6SM	26	35	44,3	40,3	39,8	38,7	37,4	35,7	33,8	32,4	31,6	31,4	28,3	24,2	
I-10SDS 200/2E 6SM	26	35	58,3	53	51,9	49	44,8	39,2	32	26,7	23,7	-	-	-	
I-10SDS 200/2DE 6SM	30	40	62,4	56,5	55,5	52,8	49,3	44,5	38,1	33,3	30,7	29,8	-	-	
I-10SDS 200/2DE 8SM	30	40	62,9	57,5	56,4	53,8	50,3	45,6	39,2	34,5	31,9	31,1	-	-	
I-10SDS 200/2CD 6SM	37	50	72,2	65,8	64,6	61,9	58,9	55,1	50	46,1	43,9	43,2	34,4	-	
I-10SDS 200/2CD 8SM	37	50	73	67,8	66,7	64,1	60,9	57	51,9	48,2	46,1	45,4	37	-	
I-10SDS 200/2BC 6SM	45	60	82,6	74,8	73,7	71,4	68,7	65,2	60,8	57,6	55,8	55,2	48,1	-	
I-10SDS 200/2BC 8SM	45	60	83,7	76,2	75,2	73	70,4	67,2	63,1	60	58,3	57,7	50,9	-	
I-10SDS 200/2AB 8SM	51	70	91,5	82,8	81,8	79,6	77,2	74,3	70,6	68	66,5	66	59,7	51,2	
I-10SDS 200/3D 8SM	51	70	99,6	93	91,7	88,4	83,8	77,8	70,2	64,8	61,9	60,8	48,9	-	
I-10SDS 200/3CD 8SM	59	80	109	101	99,6	96,6	92,6	87,2	80	74,7	71,8	70,7	58,9	-	
I-10SDS 200/3BC 8SM	66	90	125	115	113	111	108	103	96,8	92,1	89,5	88,6	78,1	66	
I-10SDS 200/3AB 8SM	75	100	136	123	122	120	117	114	109	106	104	103	92,7	80,2	
I-10SDS 200/4D 8SM	66	90	133	124	122	118	112	104	94,1	86,9	82,9	81,4	64,9	-	
I-10SDS 200/4BC 8SM	92	125	167	152	151	147	143	137	129	123	120	118	105	88,2	
I-10SDS 200/4A 8SM	110	150	185	170	168	165	161	157	152	147	144	143	131	114	
I-10SDS 200/5CD 8SM	92	125	180	167	164	159	153	144	132	123	118	117	96	-	
I-10SDS 200/5AB 8SM	132	180	229	210	208	203	199	194	187	181	177	176	161	142	
I-10SDS 200/6CD 8SM	110	150	217	200	197	191	183	172	158	147	141	139	115	-	
I-10SDS 200/6BC 8SM	132	180	253	232	229	224	218	210	198	189	184	182	161	-	
I-10SDS 200/6B 8SM	150	200	269	246	244	239	234	227	217	209	204	203	184	159	
I-10SDS 200/7C 8SM	150	200	276	255	252	246	238	227	211	200	194	192	168	141	
I-10SDS 200/7AB 8SM	185	250	321	294	291	286	280	273	263	255	250	248	228	200	
I-10SDS 200/8C 12SM	170	230	318	294	291	284	276	264	248	236	229	226	197	161	
I-10SDS 200/8C 8SM	165	220	316	292	289	282	273	261	245	232	224	222	192	155	
I-10SDS 200/8B 8SM	185	250	359	328	323	316	309	301	288	-	-	-	-	-	
I-10SDS 200/8A 12SM	220	300	373	343	340	334	327	319	308	299	294	292	270	241	
I-10SDS 200/9C 12SM	190	260	358	330	327	320	311	298	280	265	257	254	223	189	
I-10SDS 200/9A 12SM	250	340	420	386	383	376	369	361	349	339	333	331	305	270	
I-10SDS 200/10A 12SM	280	380	469	432	428	421	413	404	391	380	374	372	345	311	
I-10SDS 200/11B 12SM	280	380	494	461	456	446	434	419	401	388	381	379	348	303	
I-10SDS 200/11A 12SM	300	400	512	474	470	461	450	437	422	411	405	403	376	333	
I-10SDS 200/12JD 12SM	240	330	453	421	416	406	392	373	347	327	315	311	265	209	
I-10SDS 200/13D 12SM	220	300	435	409	404	391	372	348	317	295	283	278	227	-	
I-10SDS 200/14D 12SM	250	340	469	445	440	425	403	374	340	317	304	300	249	-	

**P2:** Rated motor power output.  
**H:** Total head in m



**Coverage chart n ≈ 2900 rpm**

Model			Q = Flow														
			m³/h	0	180	200	220	240	260	280	300	324	340	360	385	400	432
					3000	3330	3670	4000	4330	4670	5000	5400	5670	6000	6420	6670	7200
P2			l/min	H (m) = Total head													
kW	HP	36,3		28,5	27,6	26,6	25,5	24,4	23,2	21,8	19,8	18,3	16,1	-	-	-	
I-10SDS 315/1CD 6SM	26	35	39,2	31,7	30,8	29,9	28,9	27,8	26,6	25,3	23,5	22,1	20,2	-	-	-	
I-10SDS 315/1BC 6SM	30	40	39,6	32,2	31,3	30,4	29,4	28,4	27,2	25,9	24,1	22,8	20,9	-	-	-	
I-10SDS 315/1BC 8SM	30	40	43,9	35	34,2	33,4	32,6	31,7	30,6	29,4	27,8	26,5	24,8	22,2	-	-	
I-10SDS 315/1AB 6SM	37	50	44,6	35,8	35	34,2	33,4	32,5	31,6	30,5	28,9	27,6	25,9	23,3	-	-	
I-10SDS 315/1AB 8SM	37	50	67,3	51	49,1	47,1	45	42,7	40,1	37	32,3	-	-	-	-	-	
I-10SDS 315/2DE 6SM	45	60	68,3	52,8	51	49,1	47	44,6	41,8	38,3	33	-	-	-	-	-	
I-10SDS 315/2DE 8SM	45	60	73,4	58,3	56,4	54,5	52,5	50,4	48,1	45,4	41,7	38,8	34,6	-	-	-	
I-10SDS 315/2CD 8SM	51	70	79,8	65	63,3	61,6	59,7	57,8	55,6	53,1	49,6	46,8	42,9	-	-	-	
I-10SDS 315/2BC 8SM	59	80	83	68,7	67,2	65,5	63,7	61,7	59,4	56,8	53,3	50,7	47,1	42,2	-	-	
I-10SDS 315/2B 8SM	66	90	93,6	75,6	74,2	72,9	71,4	69,8	67,9	65,5	61,9	59,2	55,3	50,2	-	-	
I-10SDS 315/2A 8SM	75	100	124	102	98,6	95,9	93,1	90,2	86,9	83,2	78	74	68,2	59,8	54,1	40,5	
I-10SDS 315/3W 8SM	92	125	139	117	116	114	111	109	105	102	95,7	91,7	86,3	78,7	73,7	61,2	
I-10SDS 315/3A 8SM	110	150	172	142	139	135	132	128	124	119	112	107	99,5	88,9	81,7	63,8	
I-10SDS 315/4B 8SM	132	180	188	159	157	155	152	148	144	139	132	127	121	111	105	88,6	
I-10SDS 315/4A 8SM	150	200	214	178	174	170	165	160	155	149	140	134	125	112	103	80,1	
I-10SDS 315/5B 8SM	165	220	225	188	184	181	177	173	168	162	153	146	137	123	-	-	
I-10SDS 315/5M 12SM	170	230	231	195	192	189	185	181	176	170	161	155	146	134	126	109	
I-10SDS 315/5I 8SM	185	250	237	201	198	195	191	187	182	177	169	163	154	142	135	115	
I-10SDS 315/5A 12SM	190	260	279	233	230	226	223	218	212	205	195	186	175	159	-	-	
I-10SDS 315/6I 12SM	220	300	313	260	255	250	245	240	233	225	212	203	189	170	-	-	
I-10SDS 315/7X 12SM	250	340	332	281	277	273	269	263	256	248	236	228	216	199	188	159	
I-10SDS 315/7A 12SM	280	380	377	316	312	307	301	295	287	278	264	254	240	219	206	172	
I-10SDS 315/8A 12SM	300	400															

**P2:** Rated motor power output.  
**H:** Total head in m

**Coverage chart n ≈ 2900 rpm**

Model			Q = Flow																			
			m³/h	H (m) = Total head																		
			l/min	0	144	162	180	198	216	234	300	385	450	457	480	499	521	540	544	568	594	630
P2		2400	2700	3000	3300	3600	3900	5000	6420	7500	7620	8000	8320	8680	9000	9070	9470	9900	10500	11000		
kW	HP																					
I-12SDS 430/1D 8SM	37	50	43,2	-	36,9	36,3	35,8	35,2	34,7	31,9	26	19,9	-	-	-	-	-	-	-	-	-	-
I-12SDS 430/1CJ 8SM	45	60	46,5	-	40,7	40,3	39,9	39,4	38,9	36,1	30,4	24,7	24,1	21,7	-	-	-	-	-	-	-	-
I-12SDS 430/1CD 8SM	51	70	48,1	-	-	42	41,6	41,2	40,7	38,1	32,7	27,5	26,8	24,7	22,6	-	-	-	-	-	-	-
I-12SDS 430/1C 8SM	59	80	53,4	-	-	47,4	47,1	46,8	46,4	44,3	39,4	34,4	33,8	31,9	30,3	28,2	26,1	25,7	-	-	-	-
I-12SDS 430/1BC 8SM	66	90	56,5	-	-	49,6	49,3	49	48,6	46,8	42,3	37,4	36,9	34,9	33,2	31,1	29,1	28,7	-	-	-	-
I-12SDS 430/1B 8SM	75	100	59,7	-	-	52,1	51,7	51,3	50,9	49,2	45,3	40,7	40,2	38,3	36,6	34,6	32,6	32,2	29,4	-	-	-
I-12SDS 430/1A 8SM	92	125	67,4	-	-	57,9	57,4	57	56,6	55,2	52,2	48,4	47,9	46,1	44,6	42,6	40,8	40,4	37,9	34,8	-	-
I-12SDS 430/2E 8SM	59	80	80,5	73,6	72,8	71,9	70,8	69,4	67,7	58,4	41	-	-	-	-	-	-	-	-	-	-	-
I-12SDS 430/2DE 8SM	66	90	85,2	77,9	77,2	76,3	75,2	73,9	72,3	63,4	47,6	34,3	-	-	-	-	-	-	-	-	-	-
I-12SDS 430/2D 8SM	75	100	89,8	-	81,9	81	80,1	78,8	77,4	69,4	54,2	41,6	-	-	-	-	-	-	-	-	-	-
I-12SDS 430/2CD 8SM	92	125	99	-	-	90,5	89,7	88,8	87,6	81,1	68,5	56,1	54,5	-	-	-	-	-	-	-	-	-
I-12SDS 430/2C 8SM	110	150	108	-	-	-	99	98,3	97,5	93	82,1	69,9	68,5	63,6	59,6	54,9	50,7	49,9	44,6	38,8	-	-
I-12SDS 430/2B 8SM	132	180	123	-	-	-	113	113	112	108	98	87,3	86	81,6	77,8	73,1	69	68,1	62,7	56,5	47,2	-
I-12SDS 430/2AB 8SM	150	200	129	-	-	-	-	117	116	112	104	93,4	92,2	88	84,4	80	76	75,2	69,9	64	55,1	-
I-12SDS 430/2A 12SM	170	230	136	-	-	-	-	123	122	118	111	101	99,9	95,9	92,5	88,3	84,6	83,8	78,9	73,4	65,1	57,2
I-12SDS 430/2A 8SM	185	250	136	-	-	-	-	122	121	117	109	99,7	98,6	94,8	91,5	87,5	83,9	83,1	78,4	72,8	64,2	55,5
I-12SDS 430/3CJ 8SM	132	180	141	-	-	-	127	126	124	116	97,6	79,1	76,9	-	-	-	-	-	-	-	-	-
I-12SDS 430/3JD 8SM	150	200	151	-	-	-	137	136	135	127	111	92,6	90,5	83,4	-	-	-	-	-	-	-	-
I-12SDS 430/3C 12SM	170	230	163	-	-	-	-	149	148	141	127	110	108	100	93,9	86,9	-	-	-	-	-	-
I-12SDS 430/3Q 8SM	185	250	169	-	-	-	-	154	152	146	132	116	114	107	101	93,5	87,3	-	-	-	-	-
I-12SDS 430/3W 12SM	190	260	176	-	-	-	-	161	160	153	140	124	122	115	110	103	96	94,7	86,7	78,1	66,1	-
I-12SDS 430/3AB 12SM	220	300	192	-	-	-	-	172	166	153	139	138	132	127	121	115	114	106	97,3	83,8	-	-
I-12SDS 430/3A 12SM	250	340	203	-	-	-	-	-	174	162	149	148	142	138	132	126	125	117	109	95,4	83,3	-
I-12SDS E430/4D 12SM	170	230	175	-	-	-	158	156	154	142	116	90,3	-	-	-	-	-	-	-	-	-	-
I-12SDS E430/4CD 8SM	185	250	195	-	-	-	177	176	173	162	139	115	112	103	-	-	-	-	-	-	-	-
I-12SDS E430/4CD 12SM	190	260	196	-	-	-	178	177	175	165	142	119	116	106	-	-	-	-	-	-	-	-
I-12SDS E430/4C 12SM	220	300	216	-	-	-	-	196	195	186	166	144	141	132	124	115	-	-	-	-	-	-
I-12SDS E430/4M 12SM	280	380	250	-	-	-	-	-	226	218	201	182	180	172	165	156	148	146	136	124	108	94
I-12SDS E430/4I 12SM	300	400	263	-	-	-	-	-	233	225	210	191	189	181	174	166	158	156	146	134	117	99,5
I-12SDS E430/4A 12SM	340	460	272	-	-	-	-	-	-	234	218	201	199	192	185	178	171	169	160	149	132	115
I-12SDS E430/5JD 12SM	250	340	252	-	-	-	-	228	225	213	185	156	152	140	130	-	-	-	-	-	-	-
I-12SDS E430/5C 12SM	280	380	271	-	-	-	-	248	246	235	210	181	178	166	156	145	-	-	-	-	-	-
I-12SDS E430/5BC 12SM	300	400	286	-	-	-	-	260	258	247	223	197	193	182	172	161	150	-	-	-	-	-
I-12SDS E430/5B 12SM	340	460	305	-	-	-	279	277	275	267	245	221	218	207	198	187	177	175	-	-	-	-
I-12SDS E430/5MN 12SM	350	475	309	-	-	-	-	281	278	268	247	223	220	210	201	189	179	177	164	149	128	-
I-12SDS E430/5K 12SM	370	500	325	-	-	-	-	-	290	280	260	237	235	225	216	206	197	195	182	168	145	-
I-12SDS E430/5A 12SM	400	540	337	-	-	-	-	-	-	287	267	246	243	234	226	216	207	205	193	179	157	137
I-12SDS E430/6BJ 12SM	350	475	333	-	-	-	-	304	301	288	259	226	222	208	196	182	170	-	-	-	-	-
I-12SDS E430/7D 12SM	280	380	305	-	-	-	276	272	268	247	203	159	-	-	-	-	-	-	-	-	-	-
I-12SDS E430/7QC 12SM	370	500	367	-	-	-	-	333	329	313	278	238	233	216	202	185	-	-	-	-	-	-
I-12SDS E430/7C 12SM	400	540	377	-	-	-	-	342	339	324	288	248	243	227	213	197	-	-	-	-	-	-
I-12SDS E430/8D 12SM	300	400	347	-	-	313	310	306	302	277	224	173	-	-	-	-	-	-	-	-	-	-
I-12SDS E430/9D 12SM	350	475	390	-	-	-	350	346	340	313	257	199	-	-	-	-	-	-	-	-	-	-
I-12SDS E430/11D 12SM	400	540	476	-	-	429	424	419	412	377	305	237	-	-	-	-	-	-	-	-	-	-

**P2:** Rated motor power output.  
**H:** Total head in m

Coverage chart  $n \approx 2900$  rpm

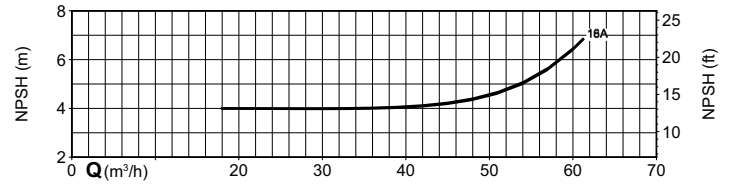
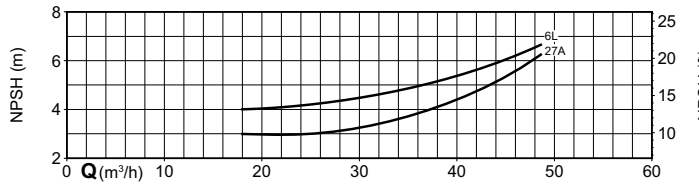
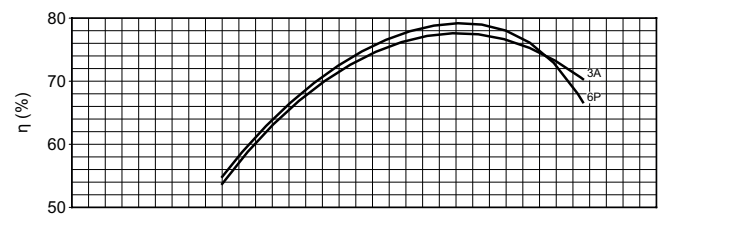
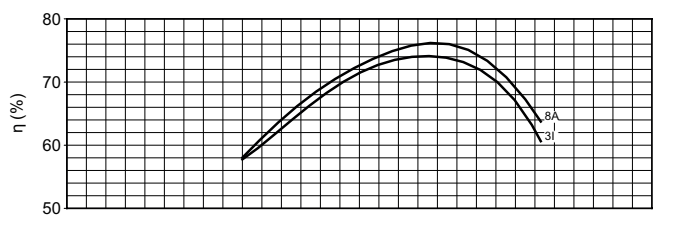
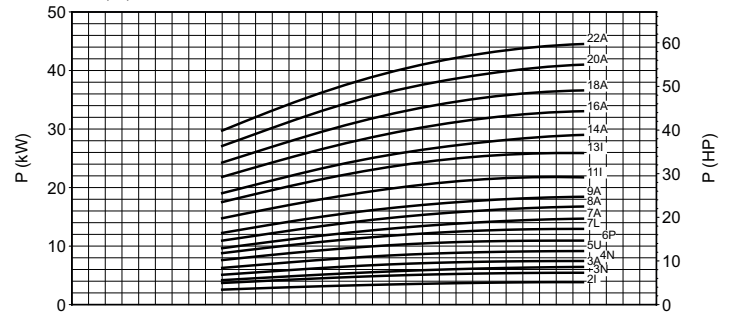
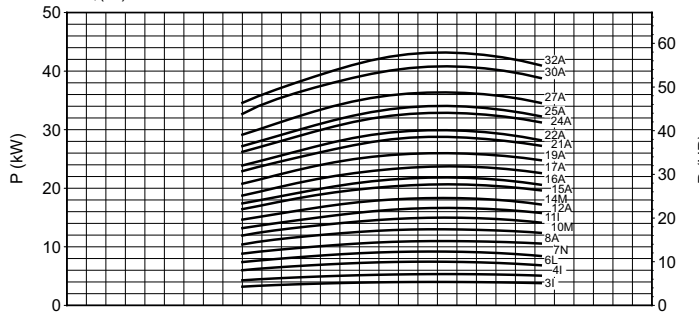
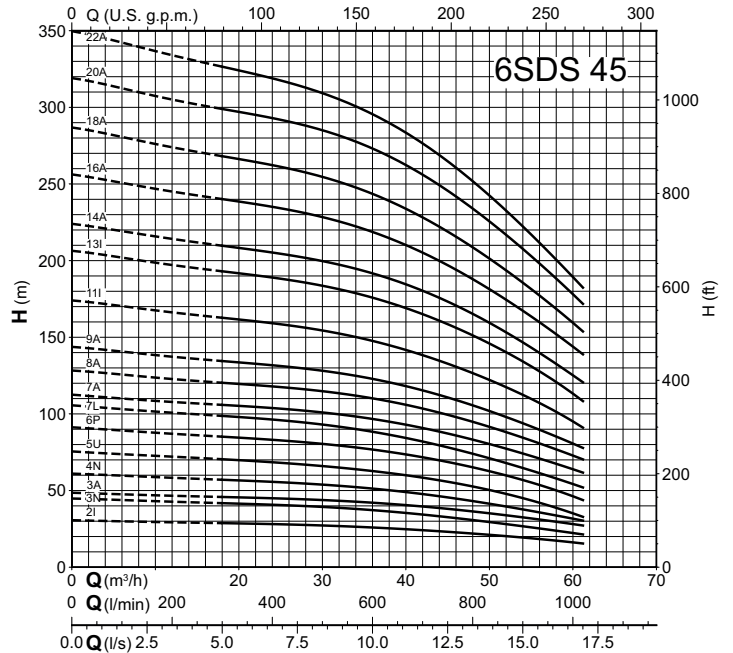
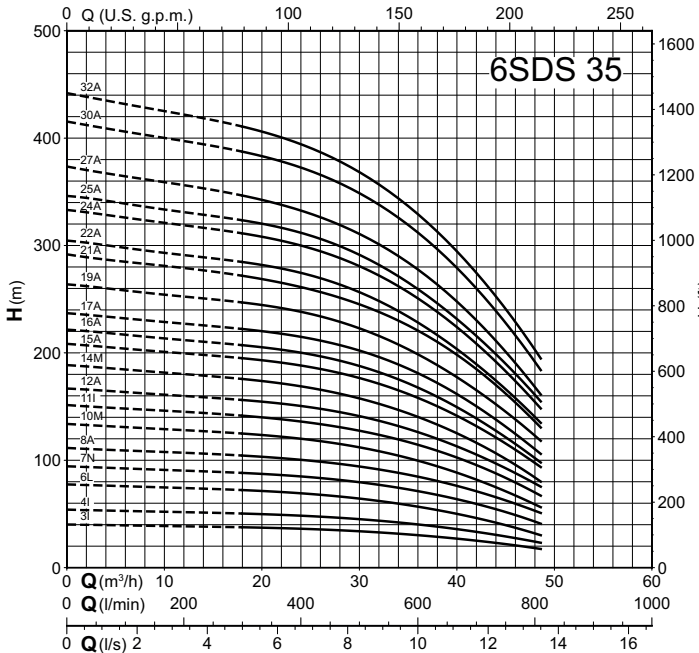

Coverage chart  $n \approx 2900$  rpm

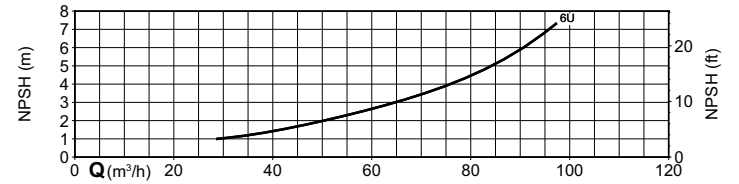
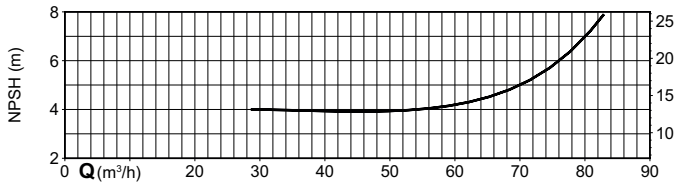
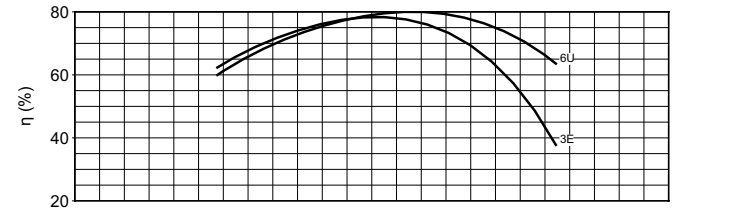
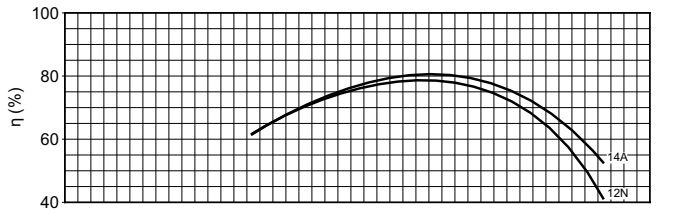
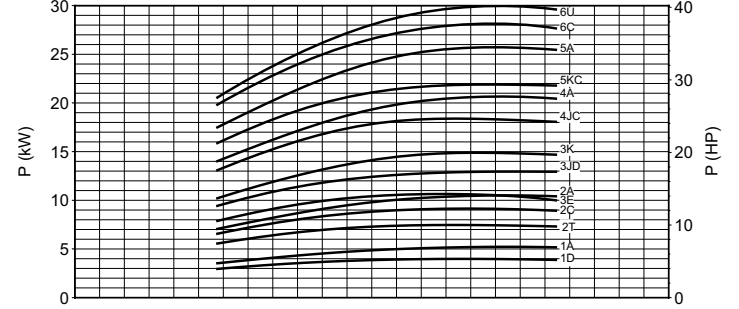
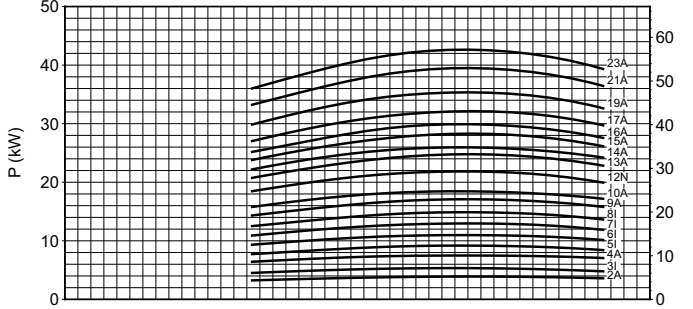
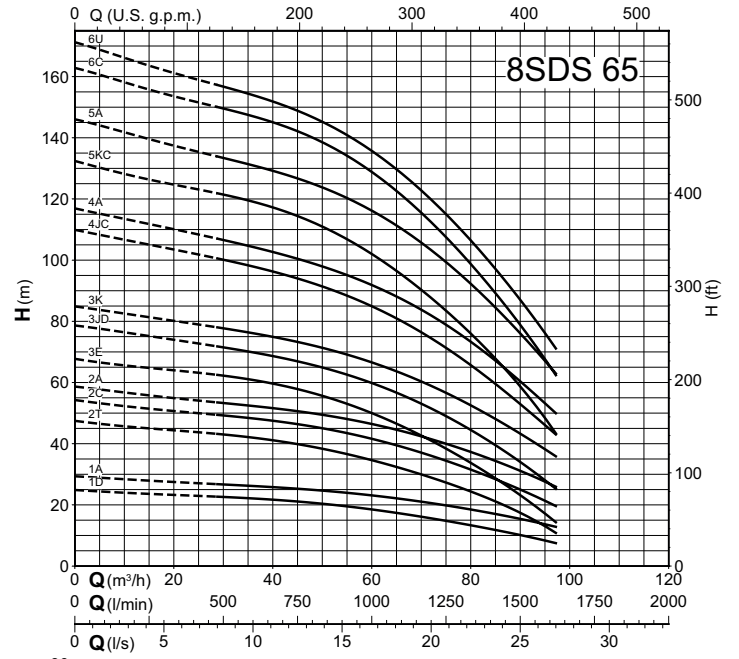
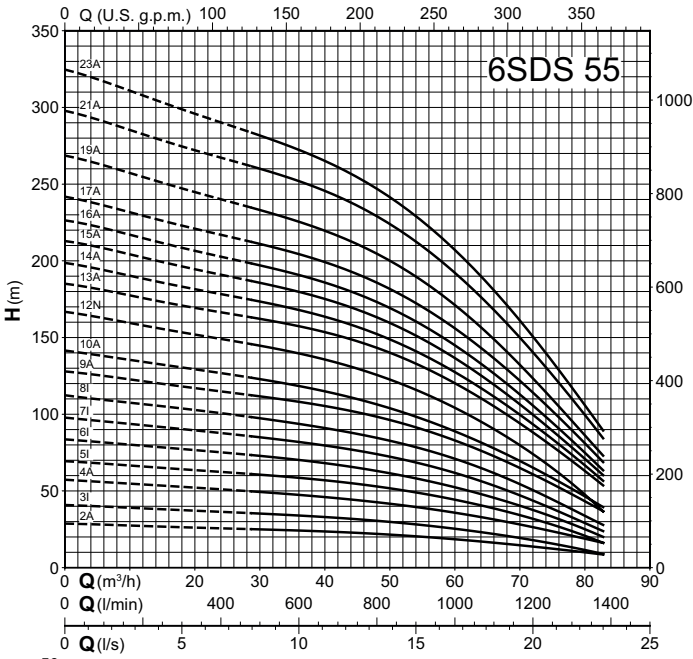

Coverage chart  $n \approx 2900$  rpm

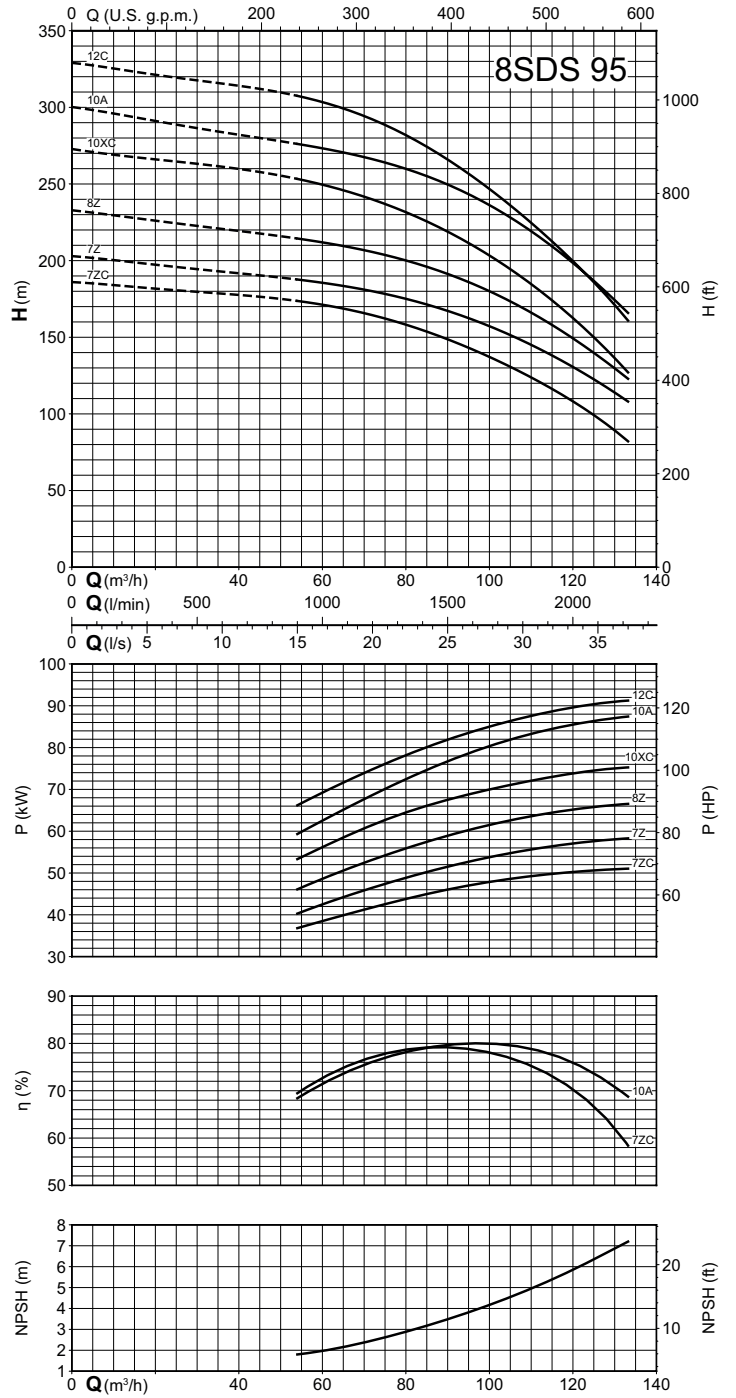
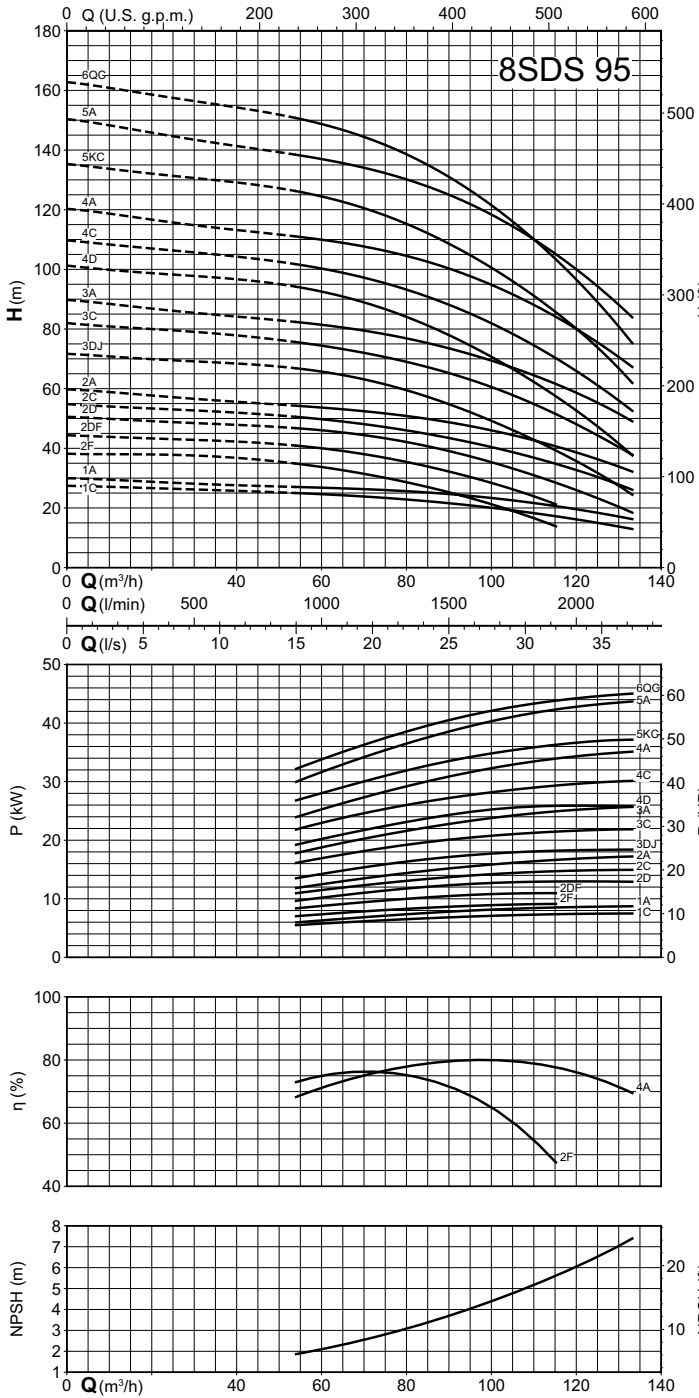

Coverage chart  $n \approx 2900$  rpm

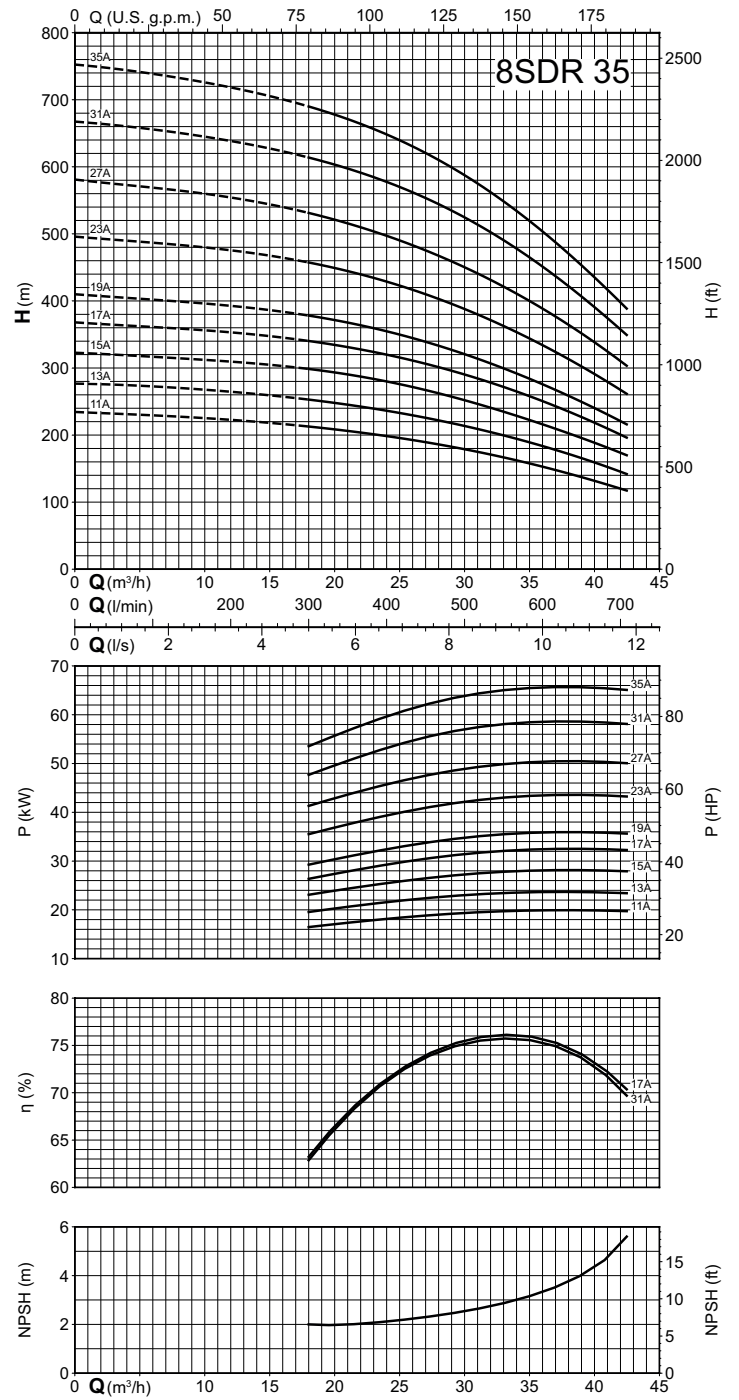
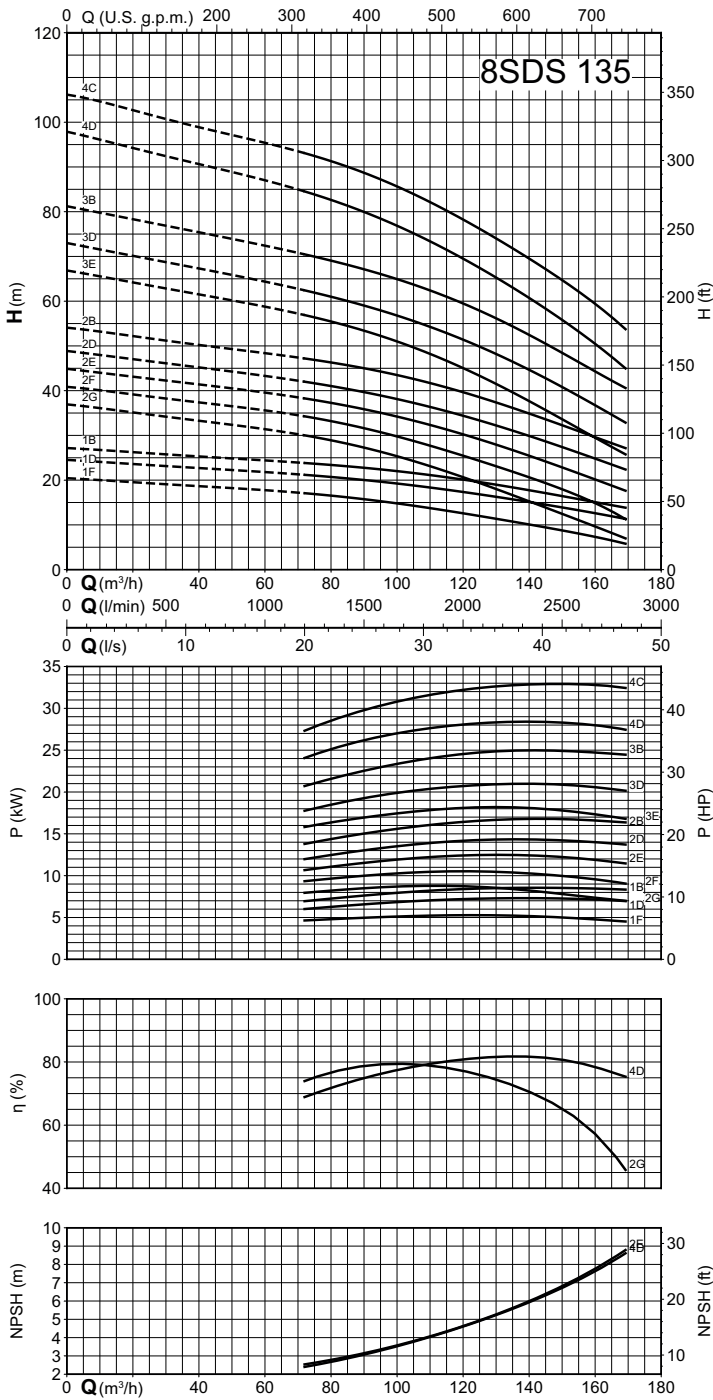

Coverage chart  $n \approx 2900$  rpm

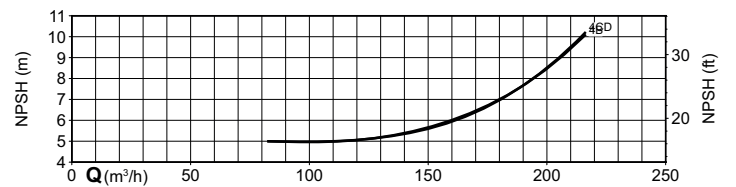
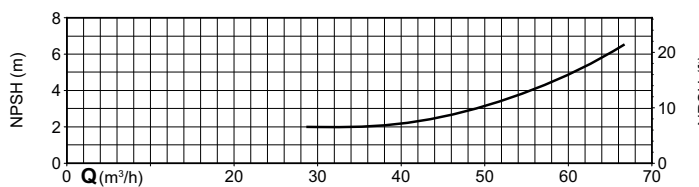
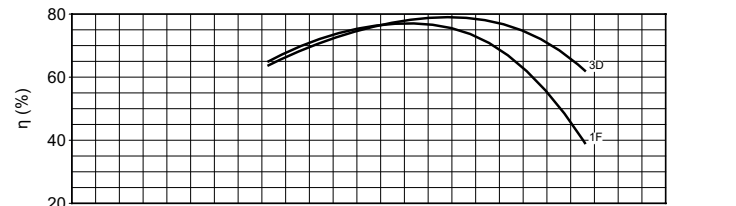
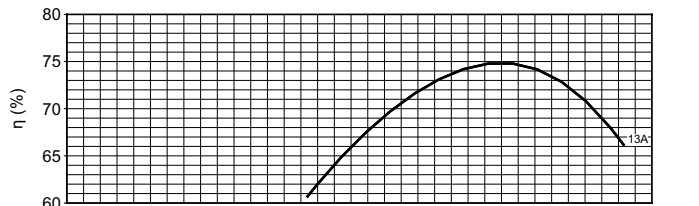
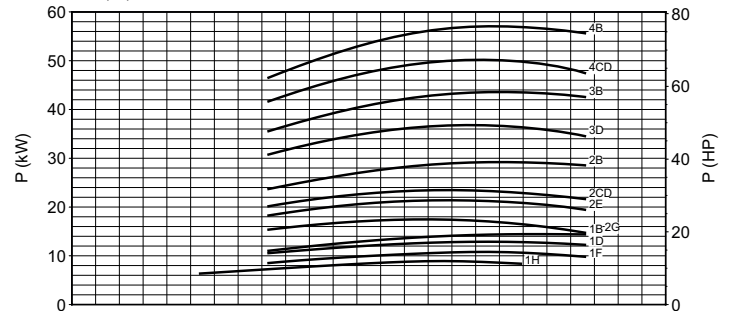
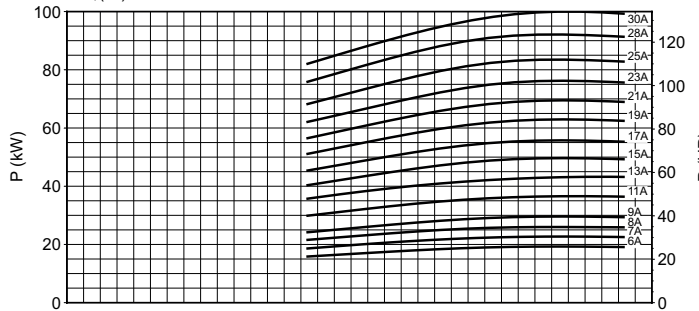
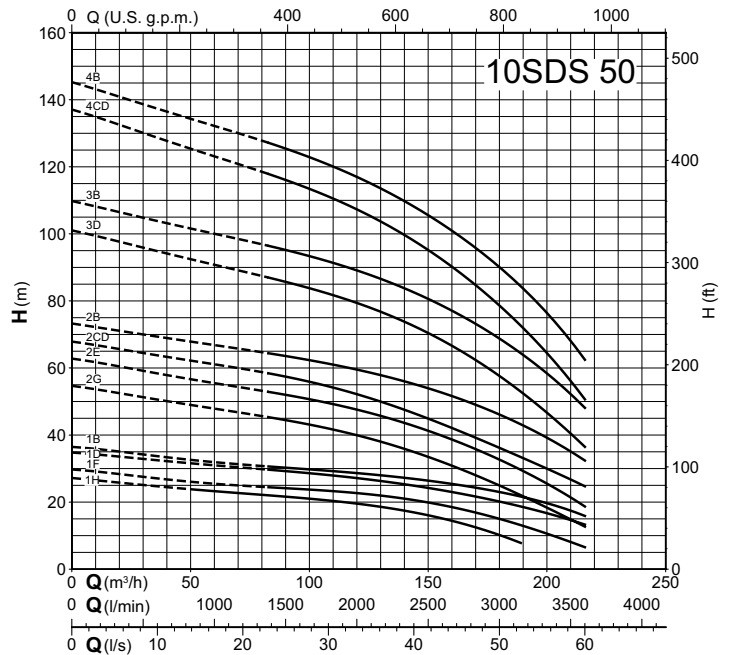
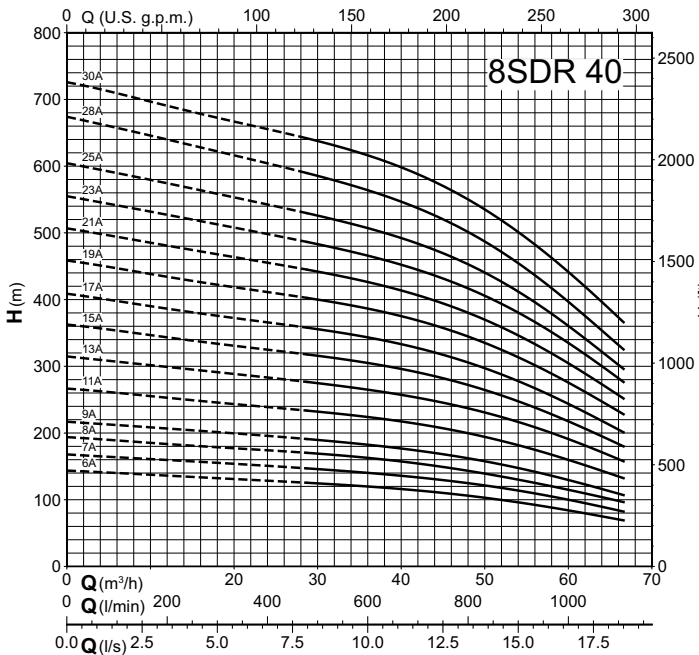

## Coverage chart $n \approx 2900$ rpm

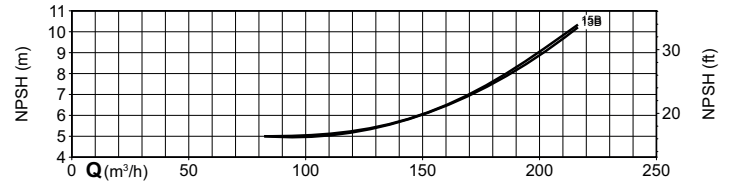
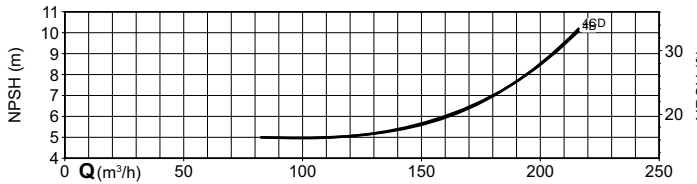
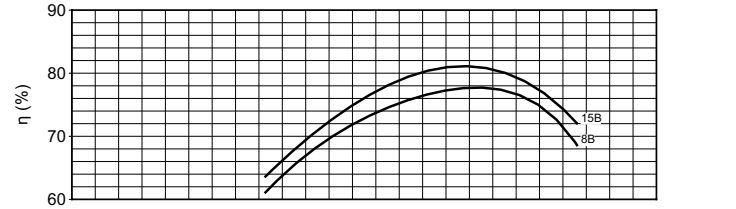
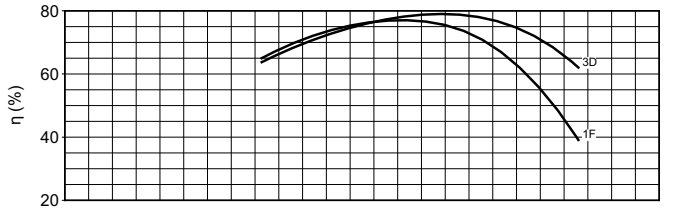
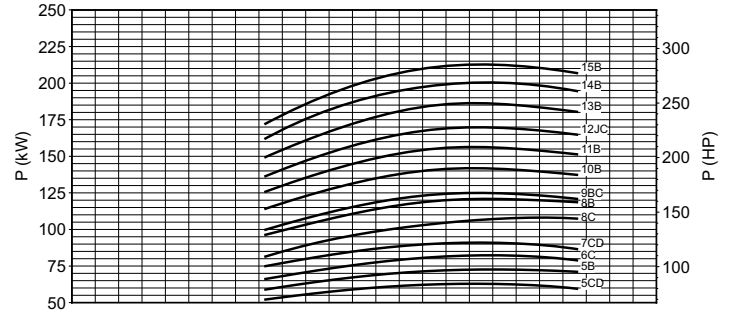
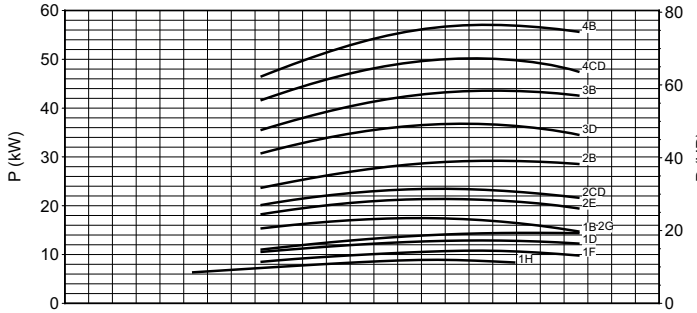
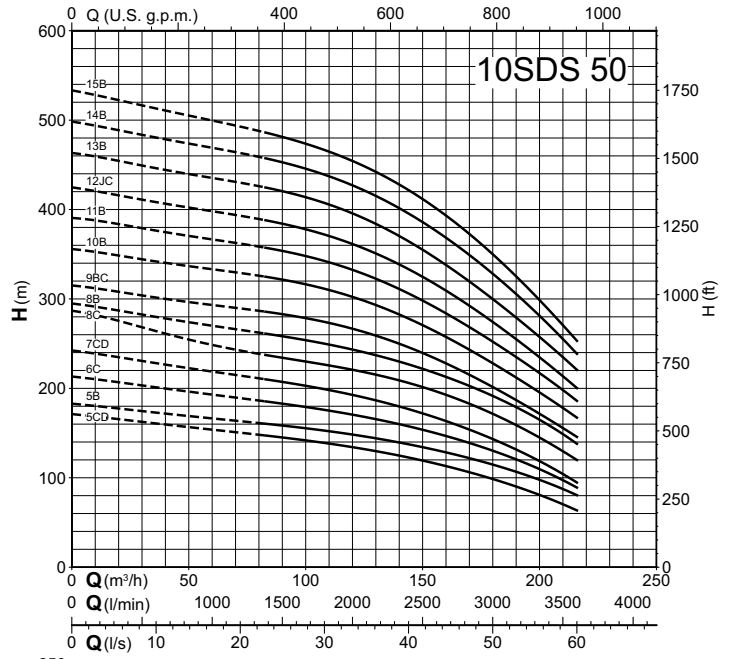
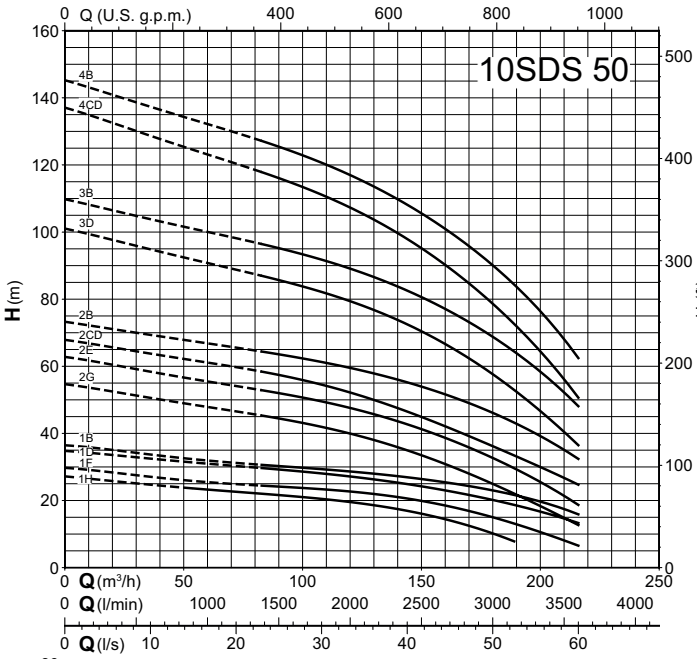

### Coverage chart $n \approx 2900$ rpm

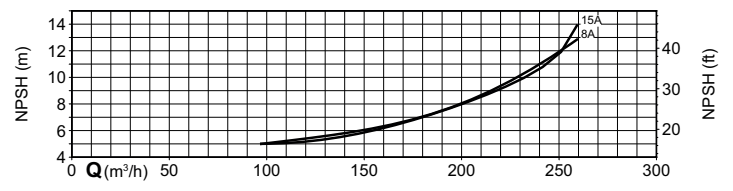
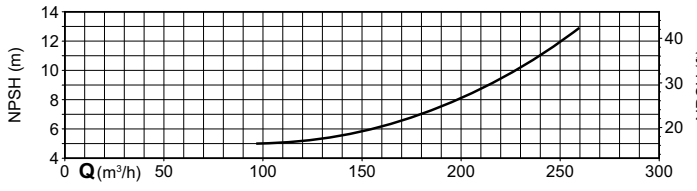
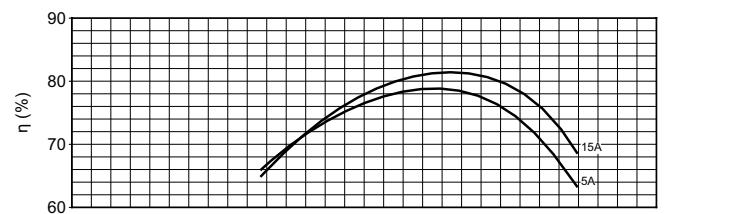
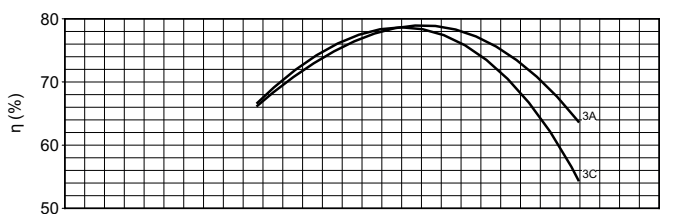
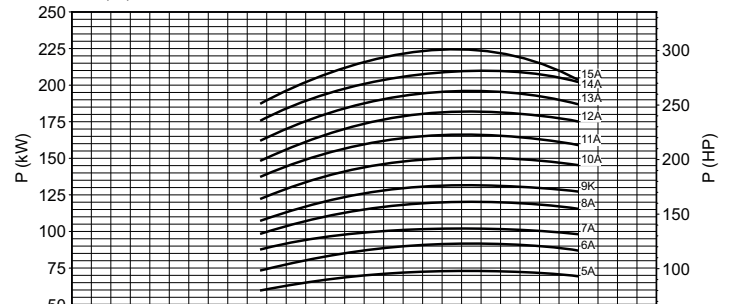
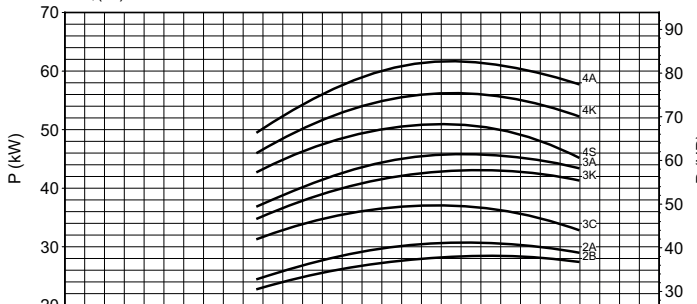
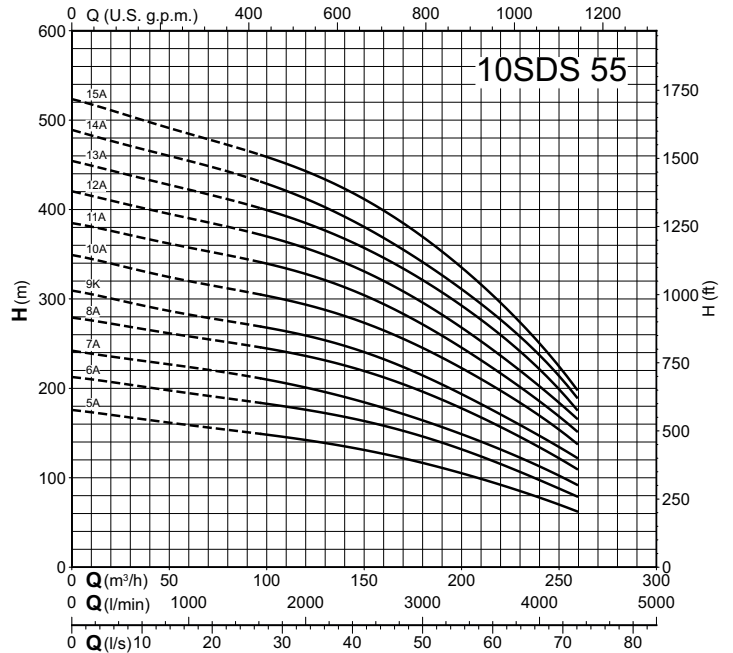
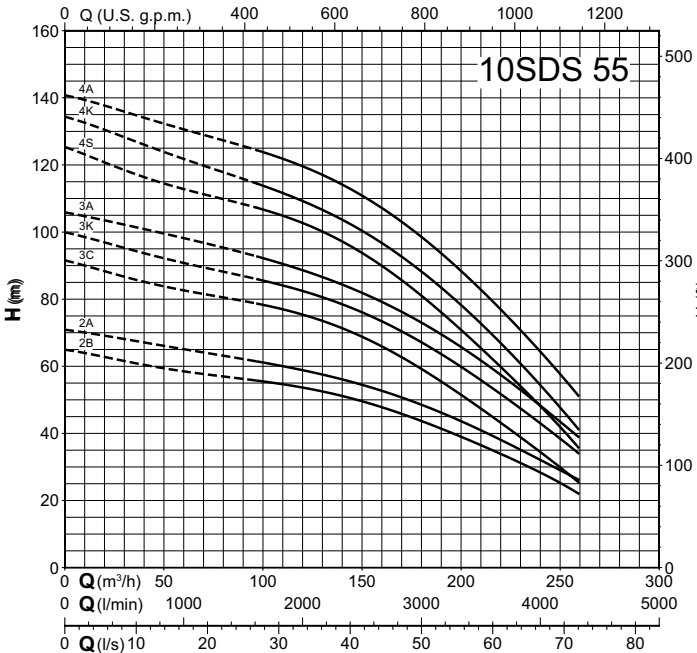

Coverage chart  $n \approx 2900$  rpm

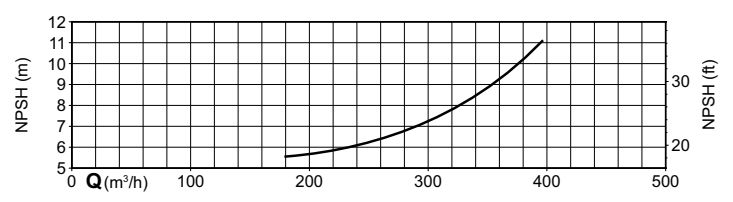
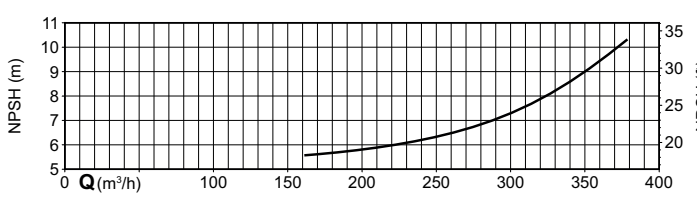
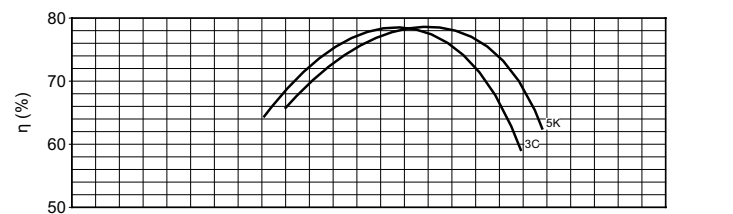
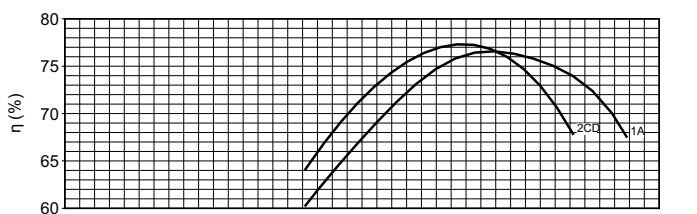
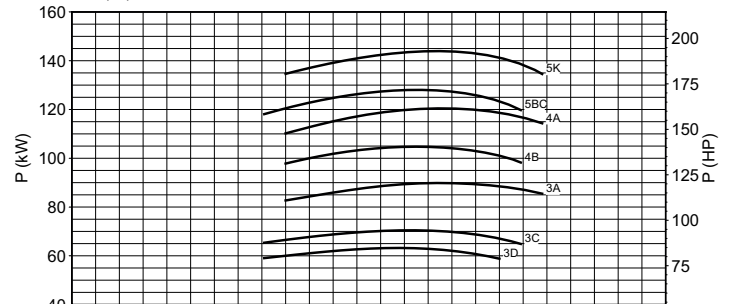
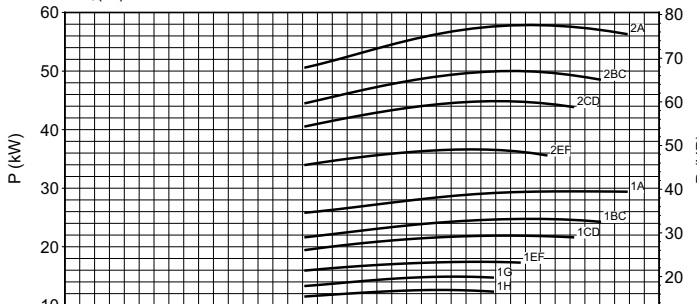
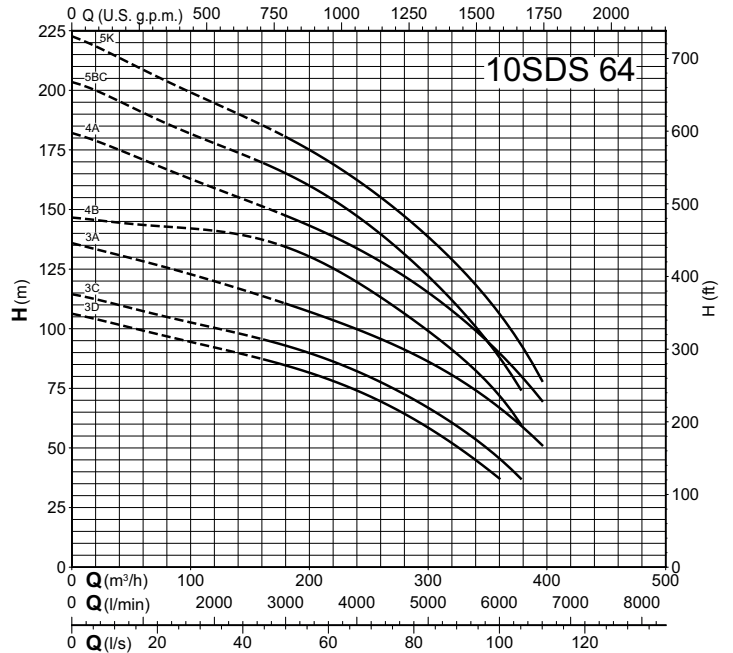
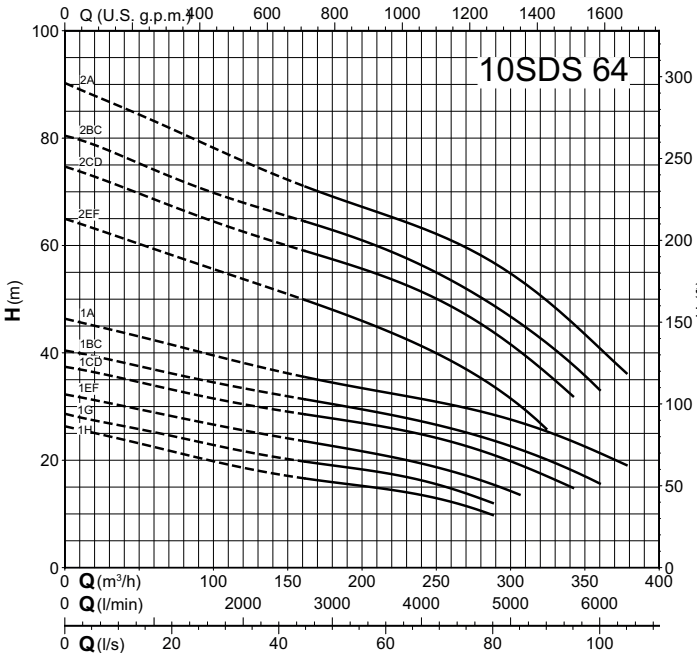

Coverage chart  $n \approx 2900$  rpm

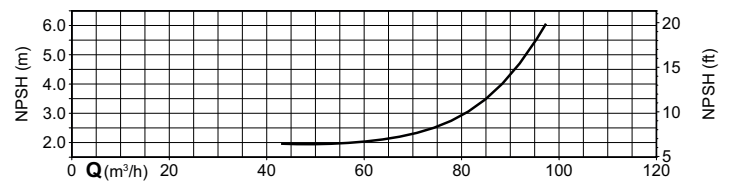
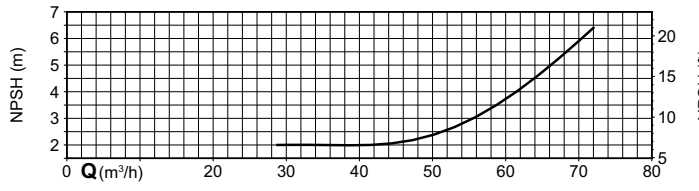
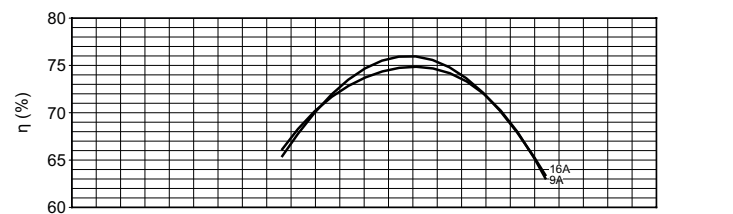
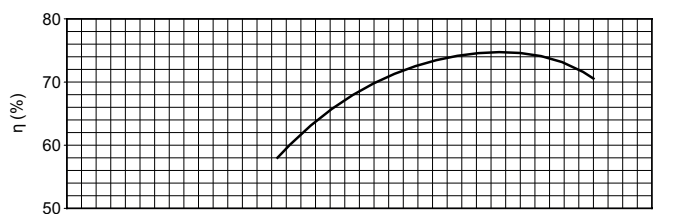
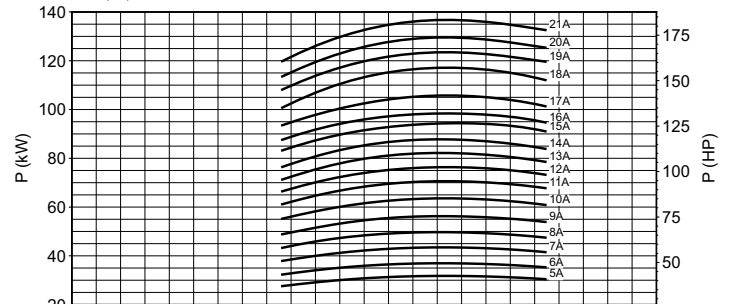
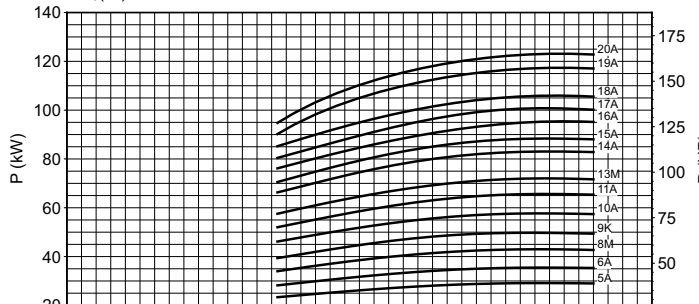
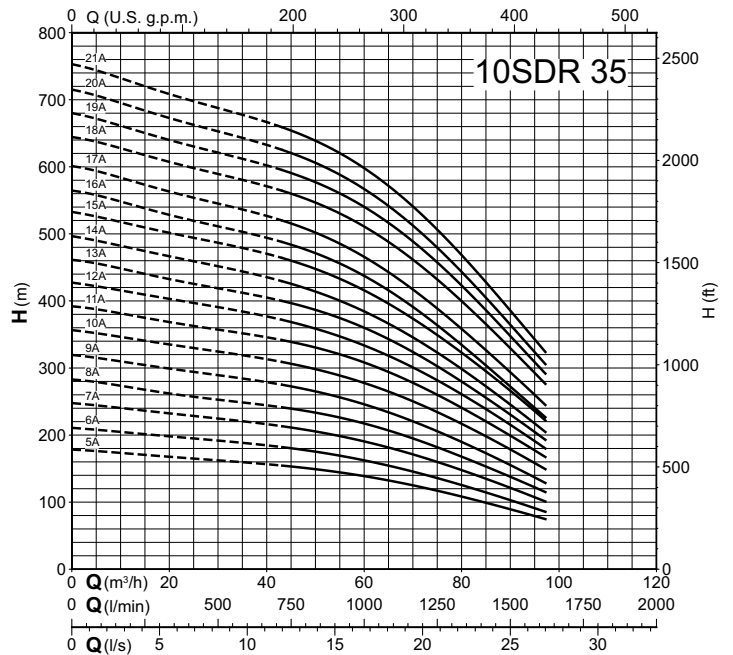
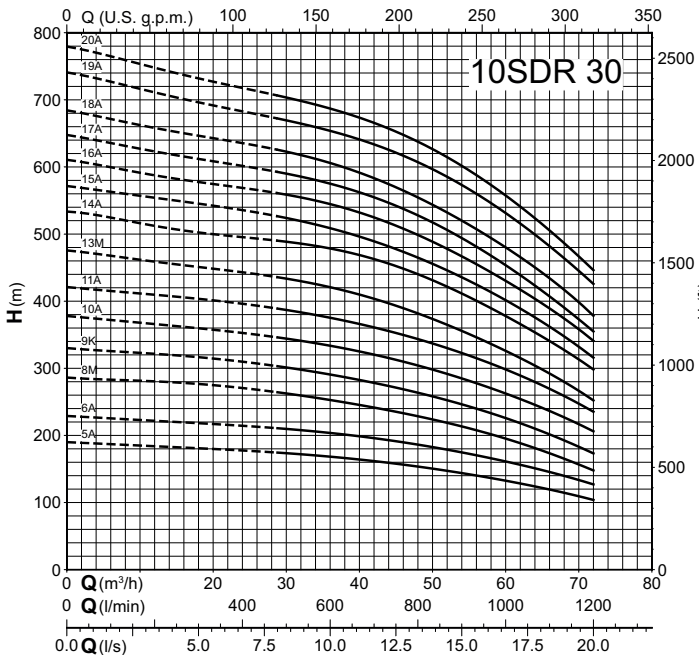

### Coverage chart $n \approx 2900$ rpm

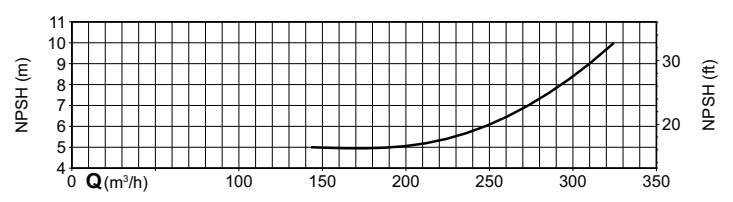
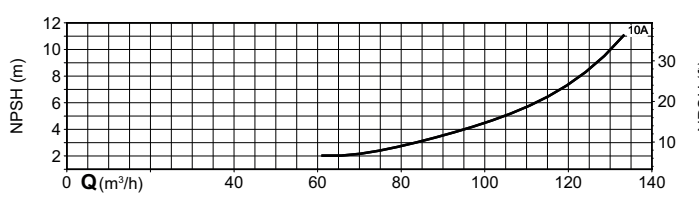
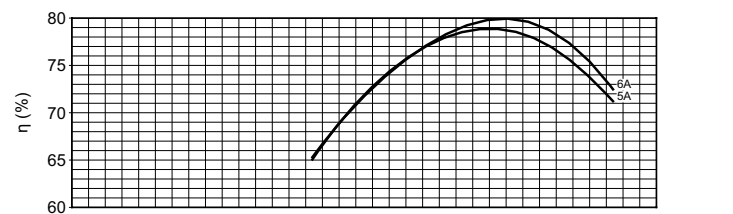
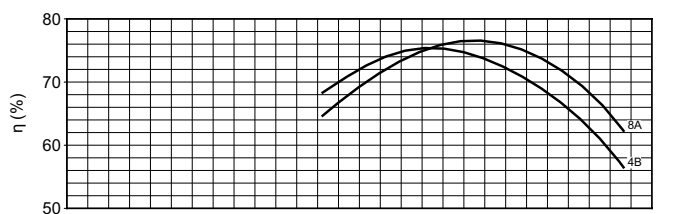
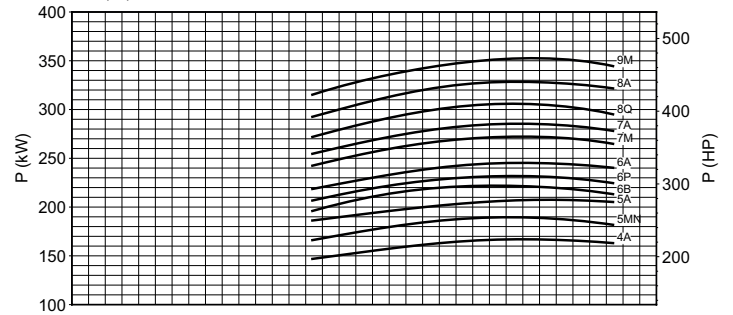
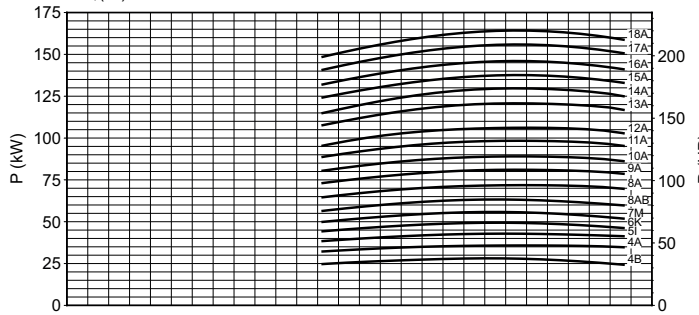
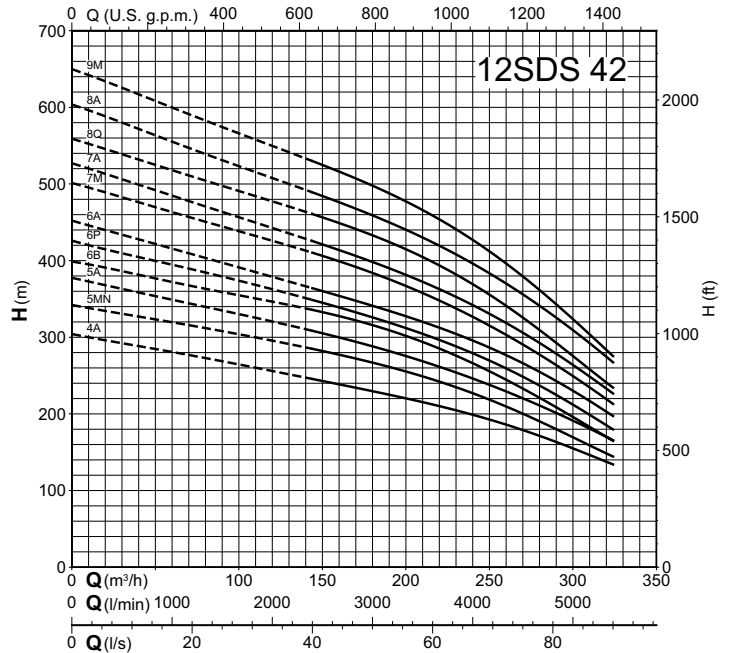
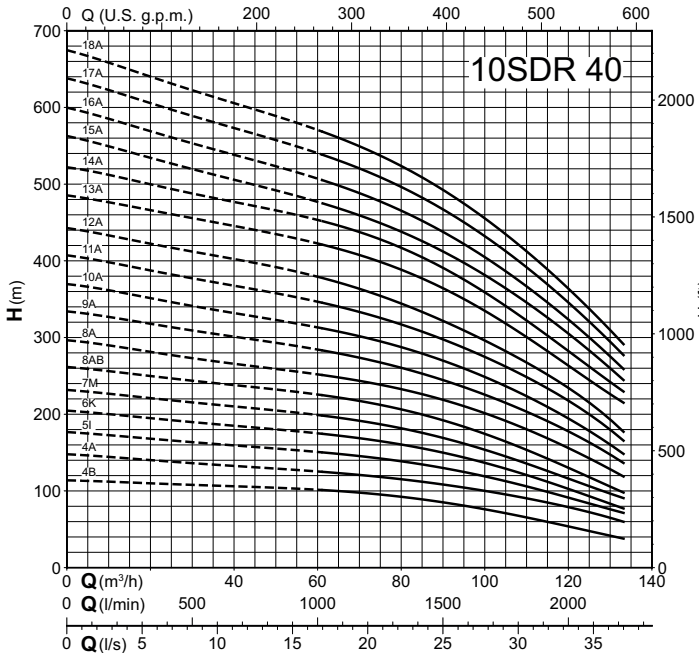

Coverage chart  $n \approx 2900$  rpm

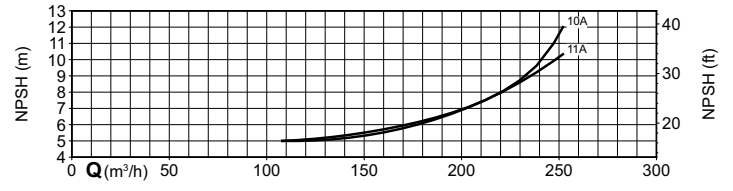
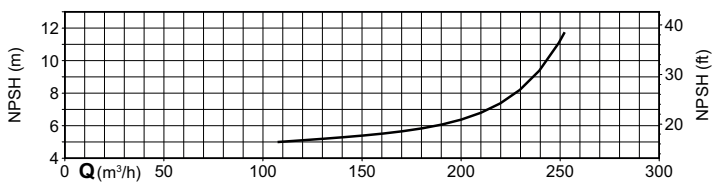
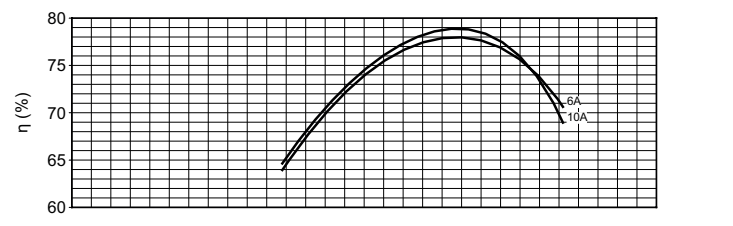
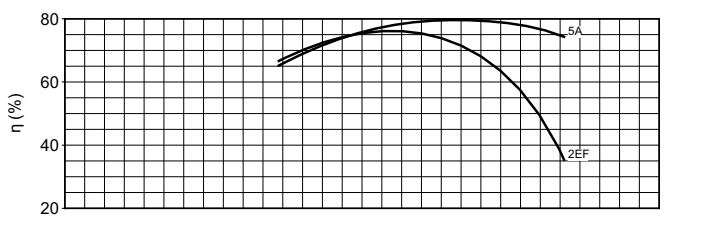
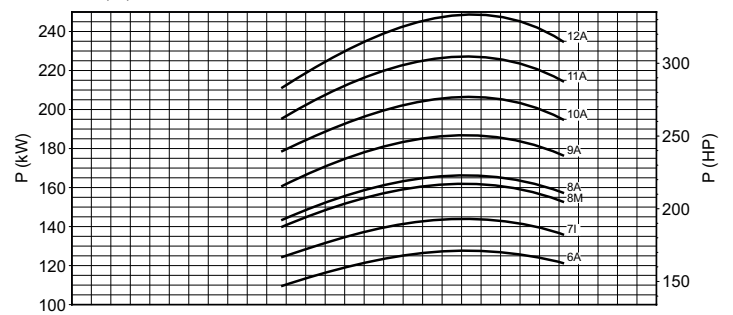
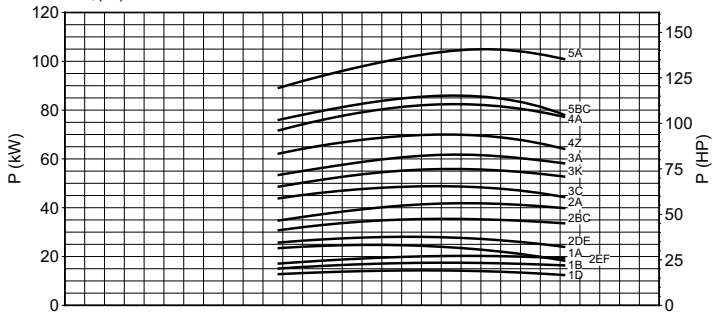
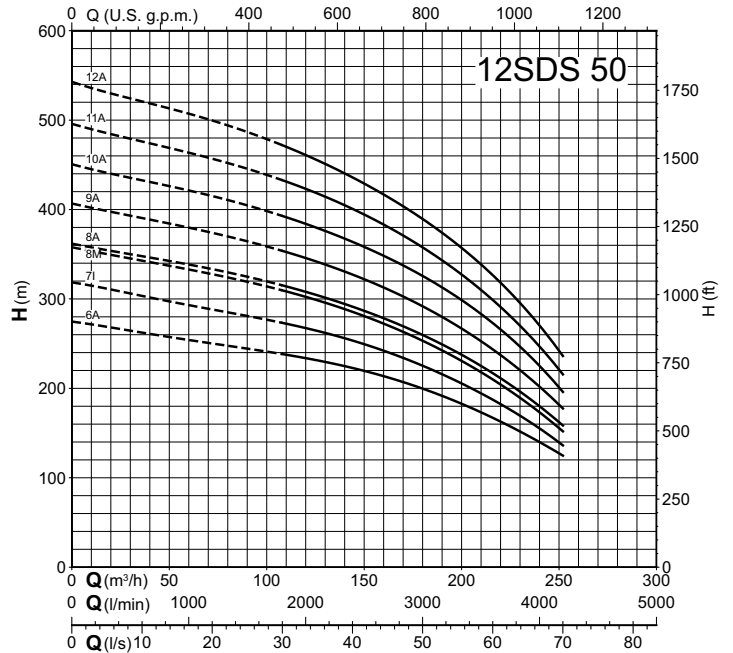
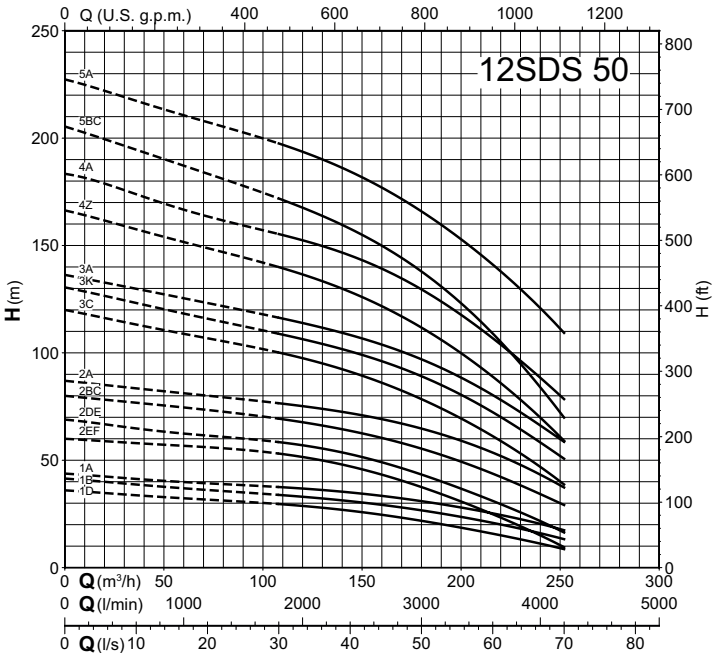

Coverage chart  $n \approx 2900$  rpm

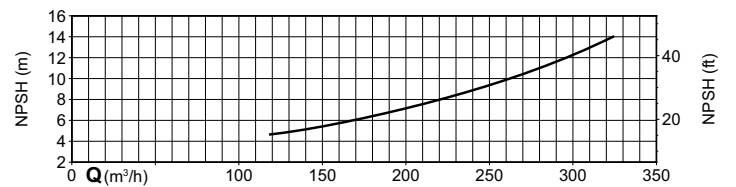
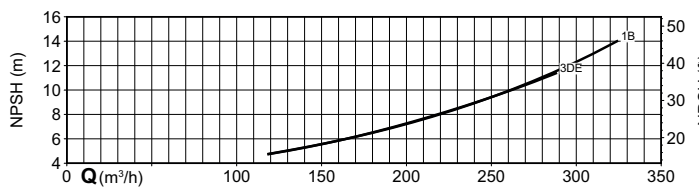
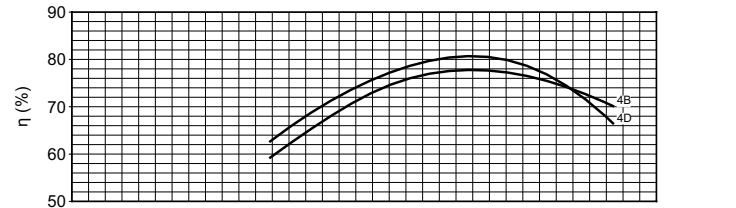
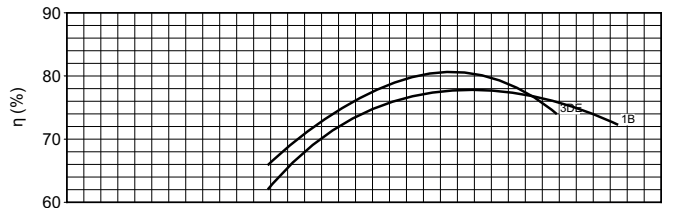
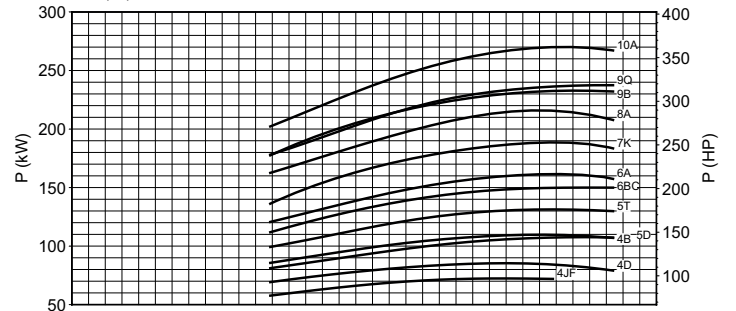
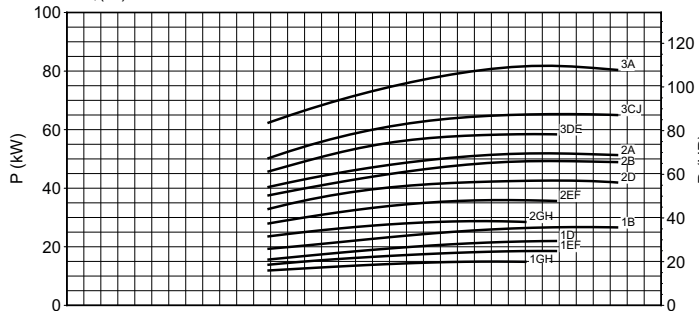
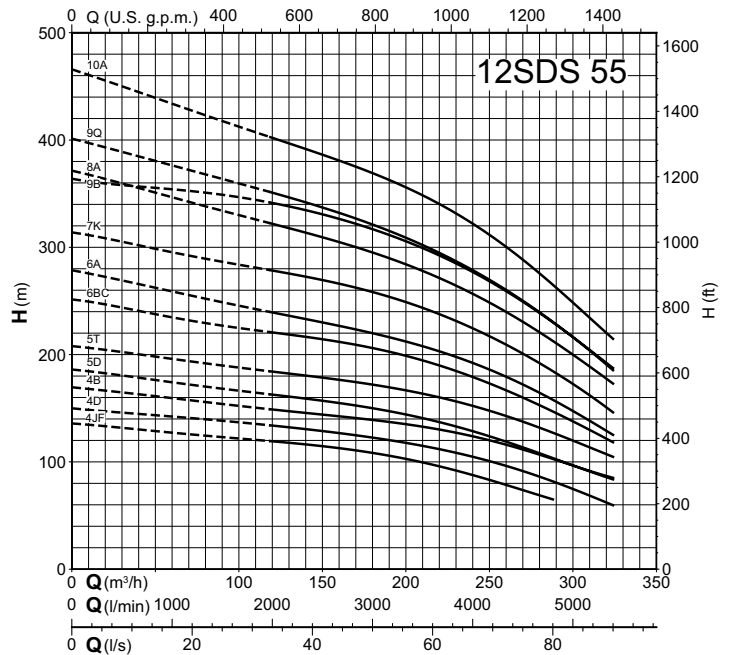
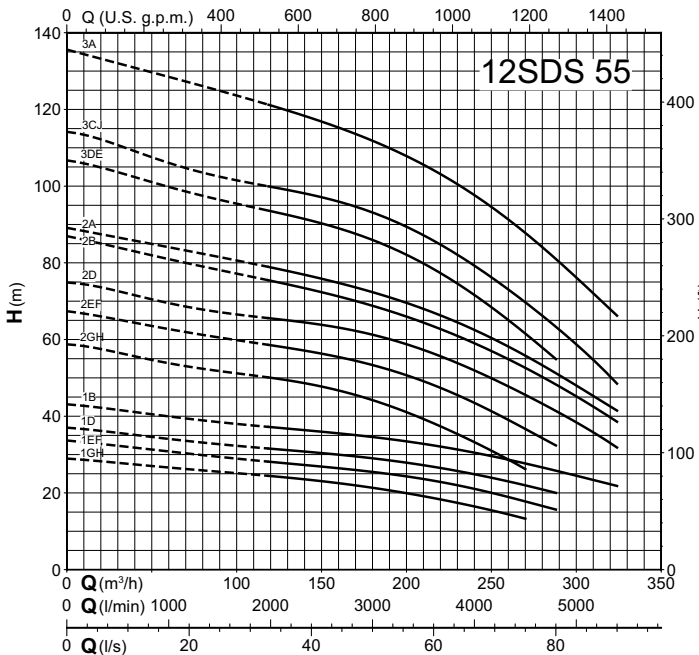

Coverage chart  $n \approx 2900$  rpm

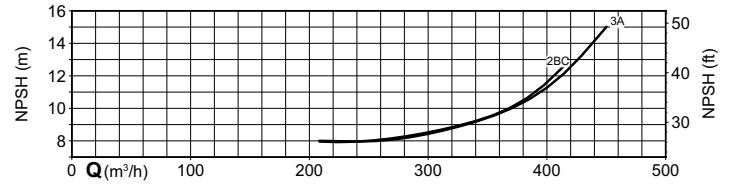
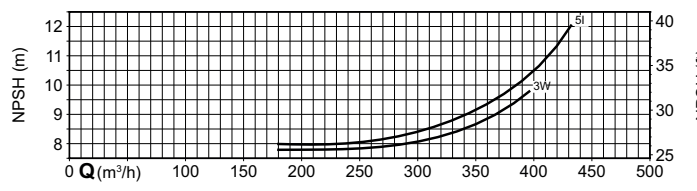
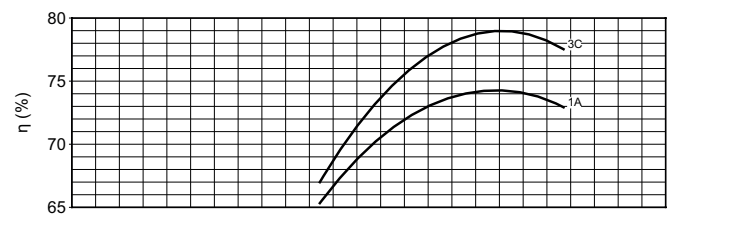
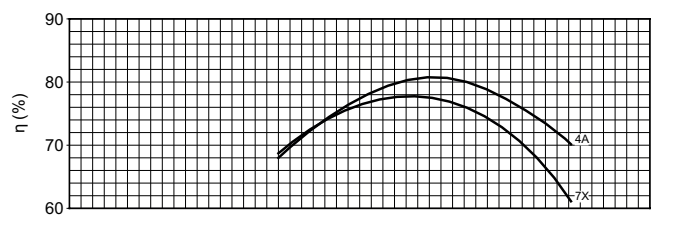
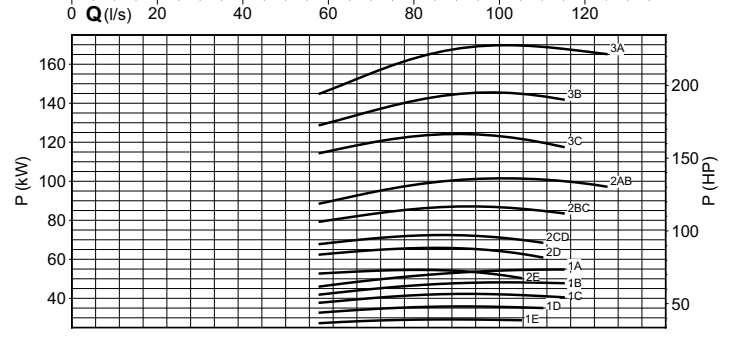
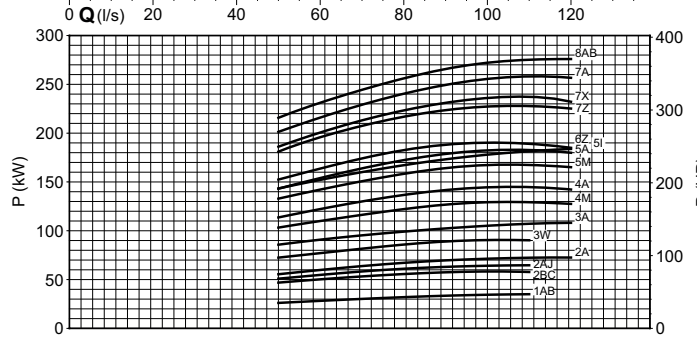
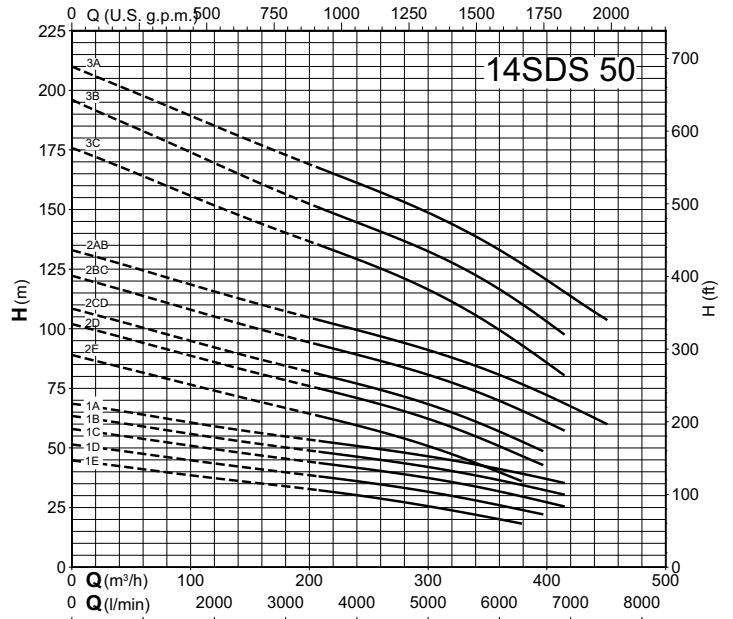
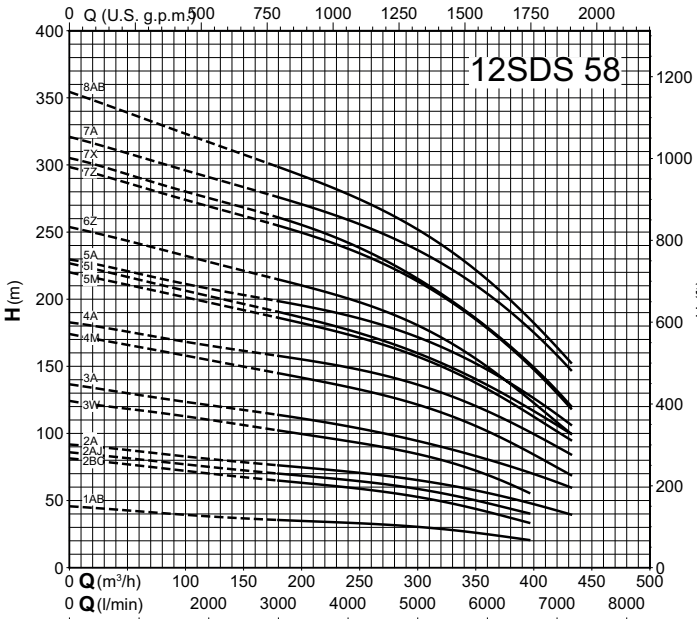

Coverage chart n ≈ 2900 rpm

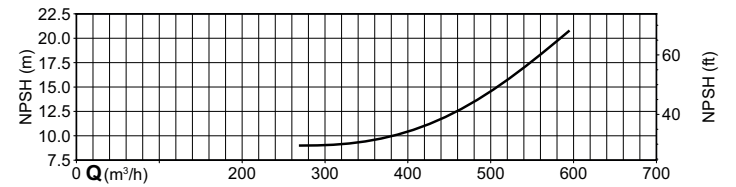
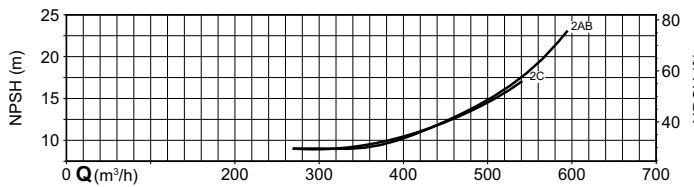
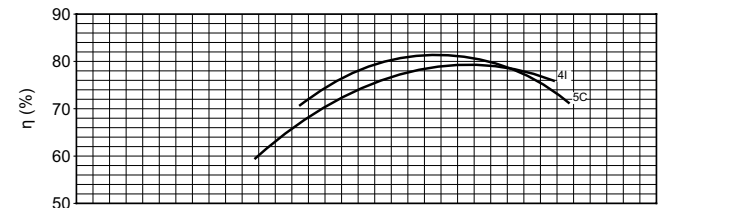
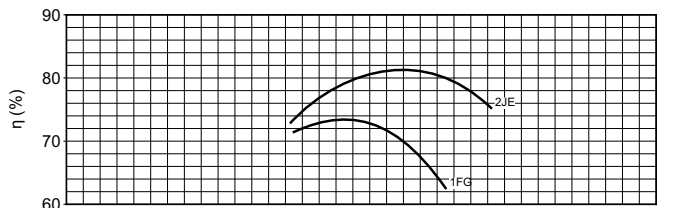
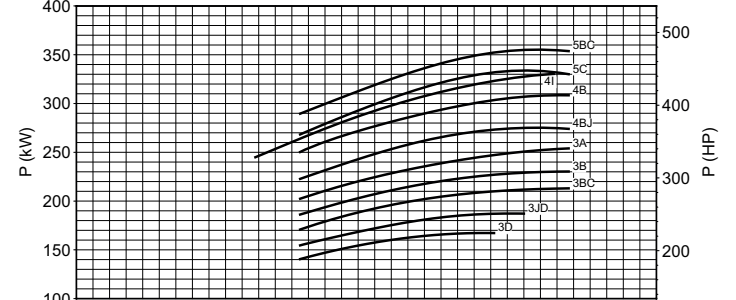
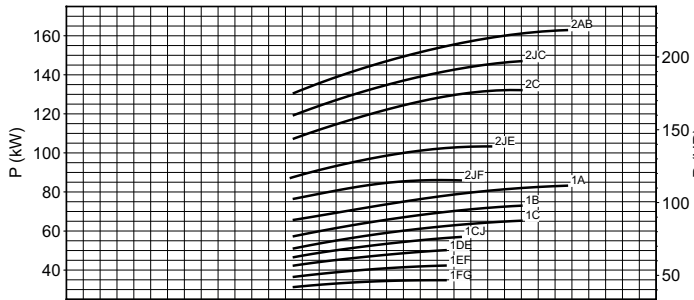
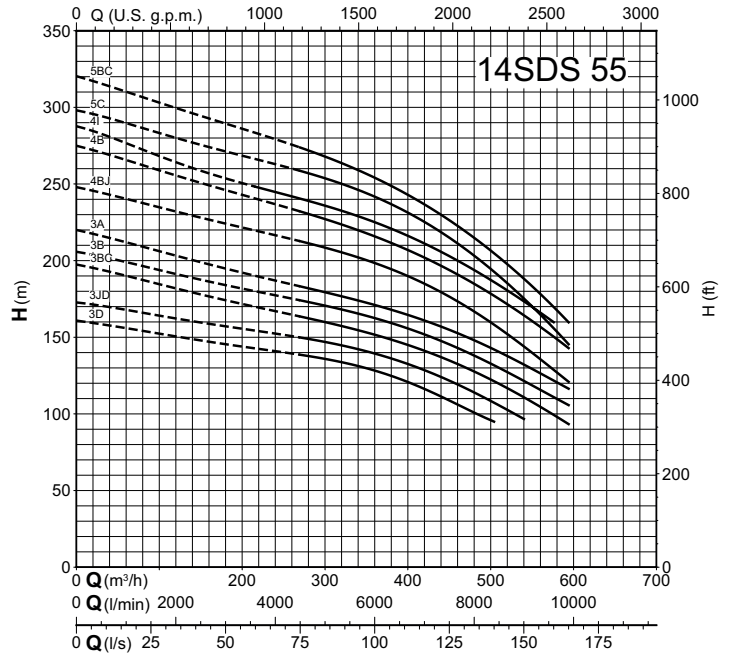
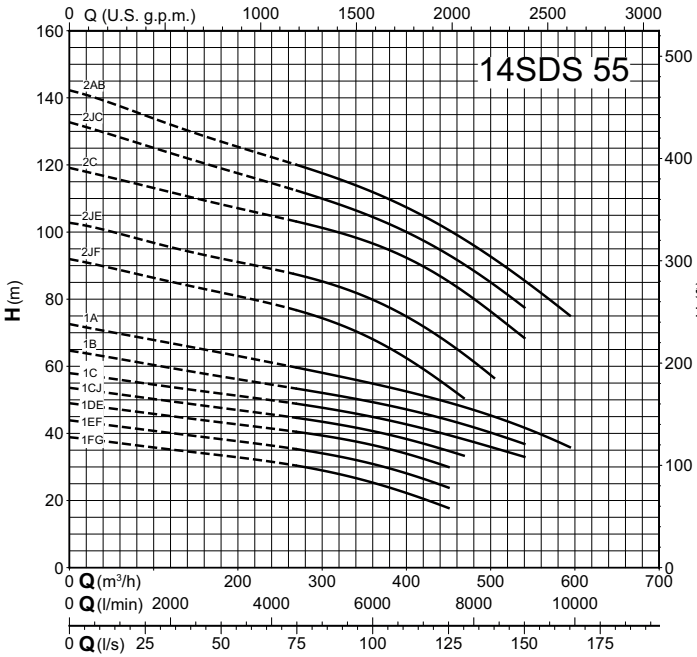

Coverage chart  $n \approx 2900$  rpm

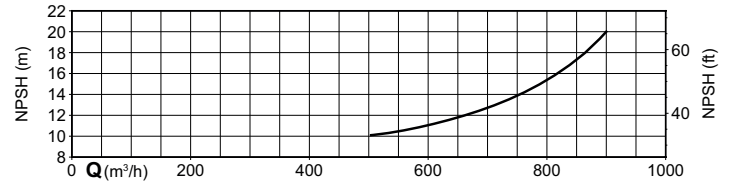
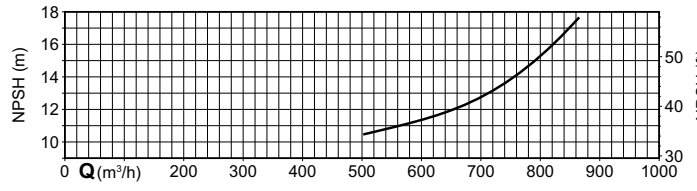
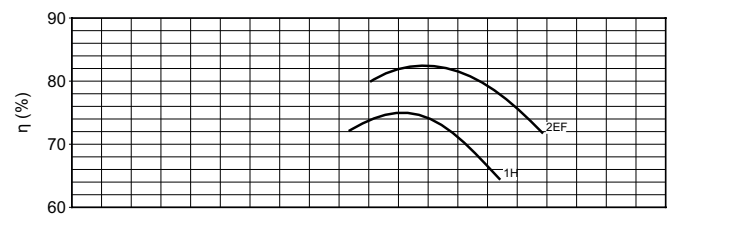
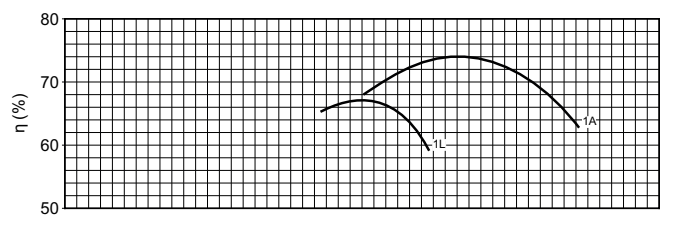
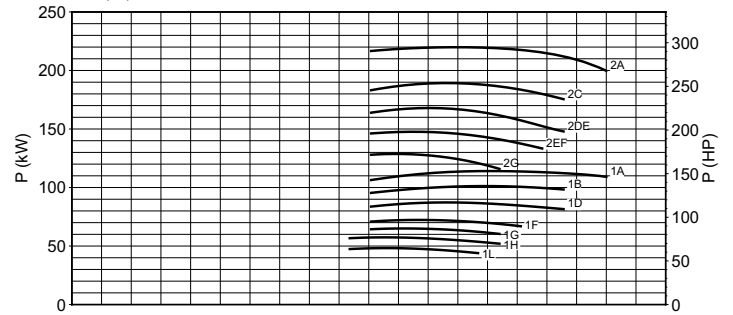
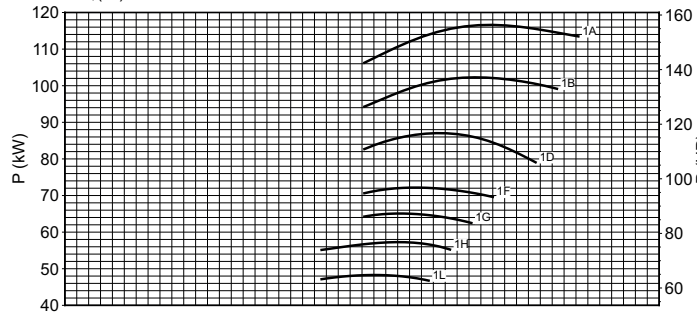
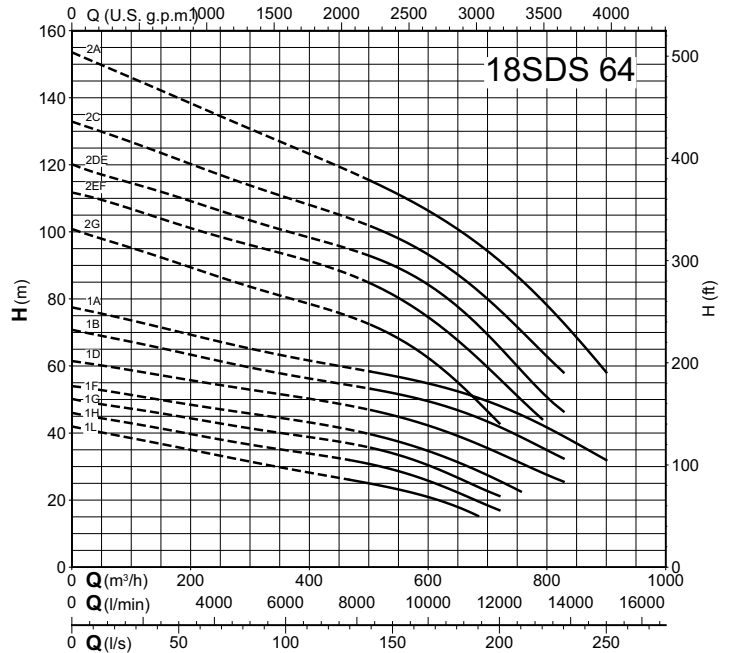
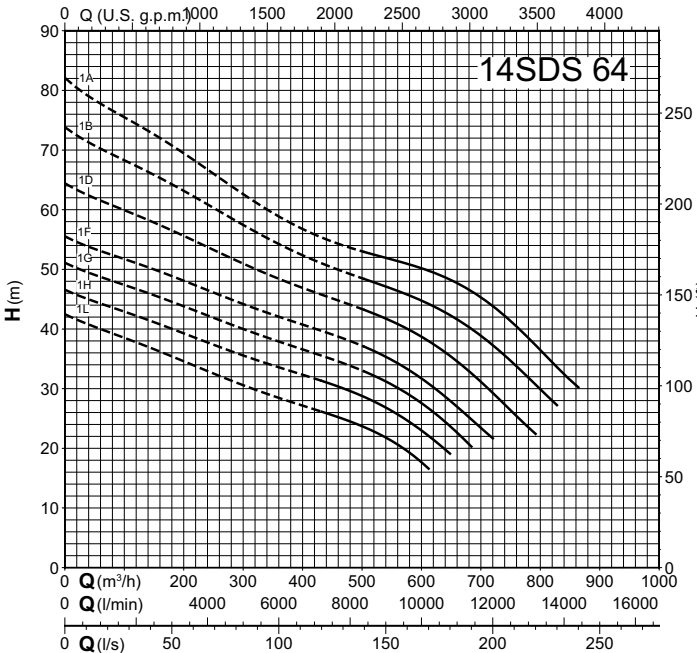

Coverage chart  $n \approx 2900$  rpm

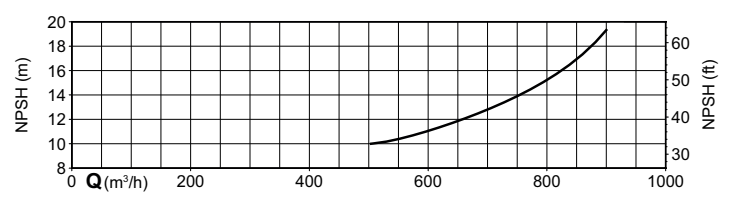
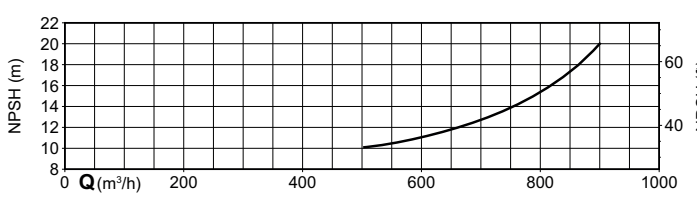
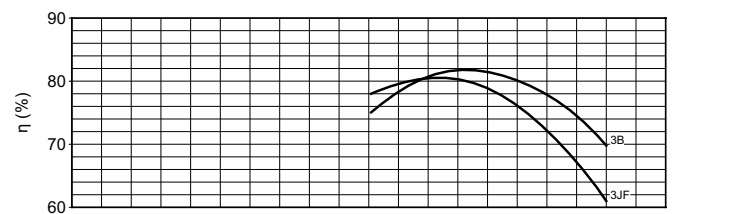
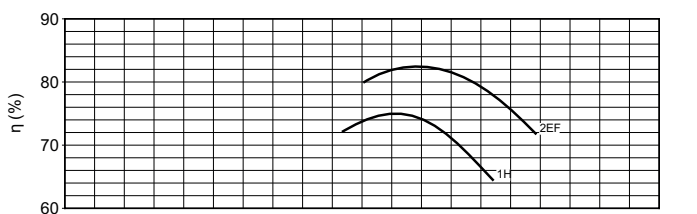
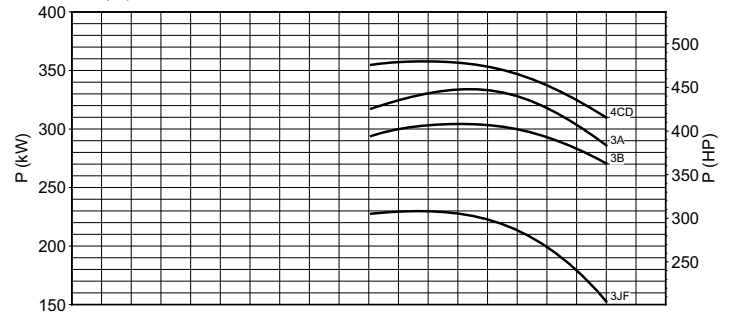
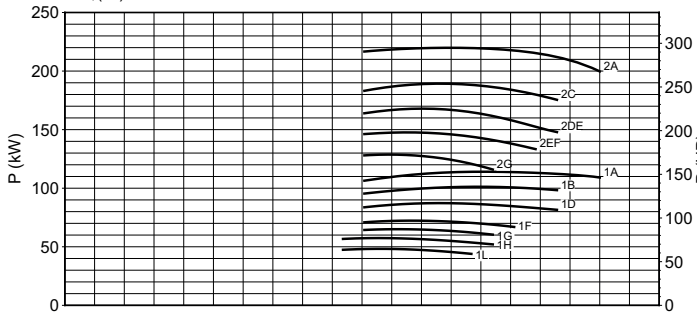
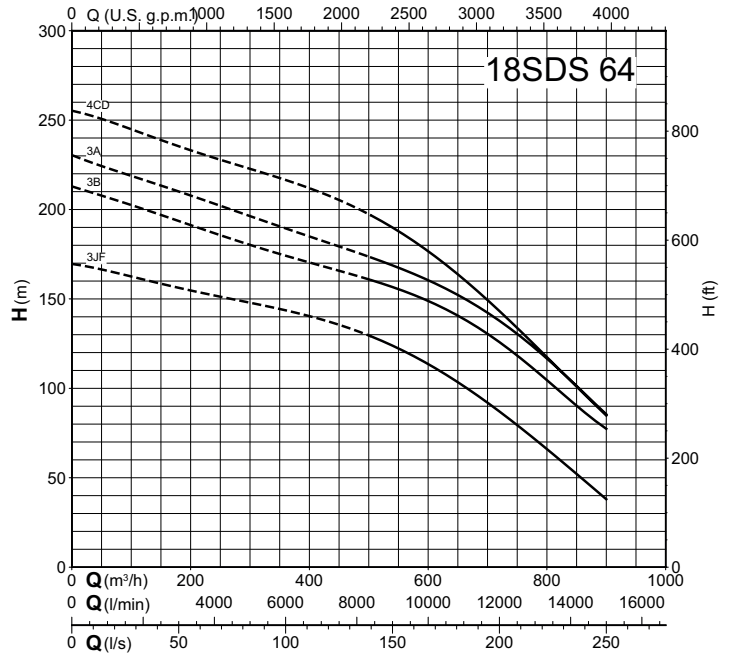
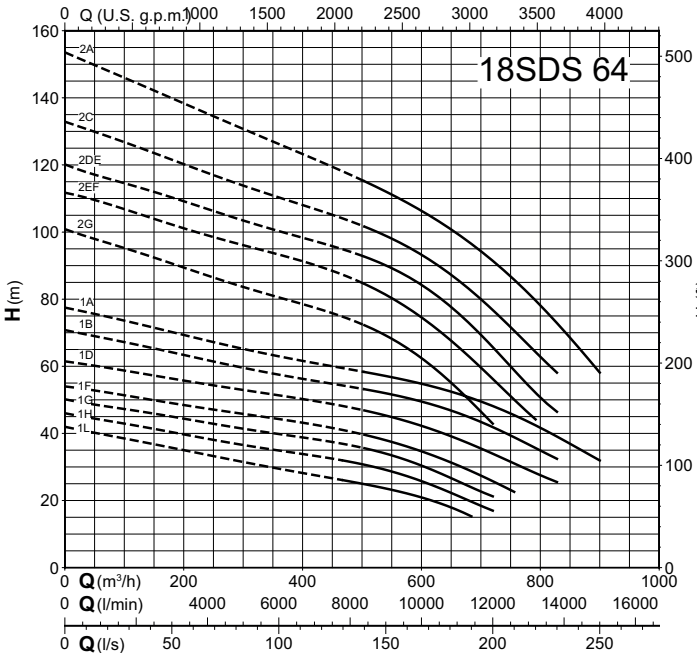

Coverage chart  $n \approx 2900$  rpm

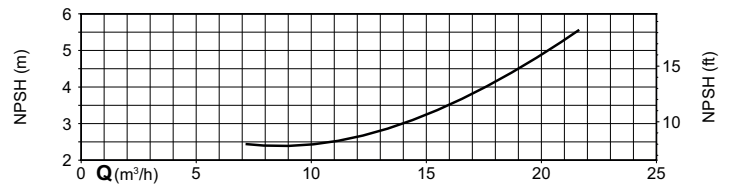
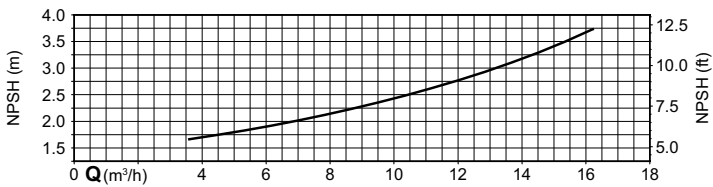
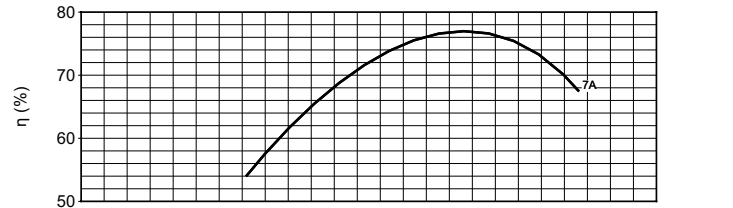
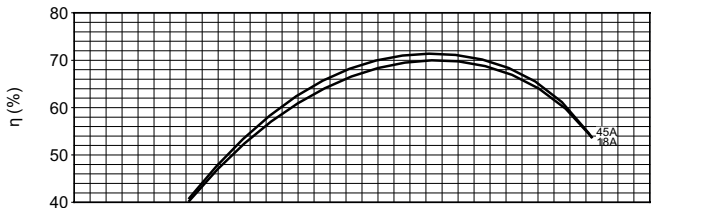
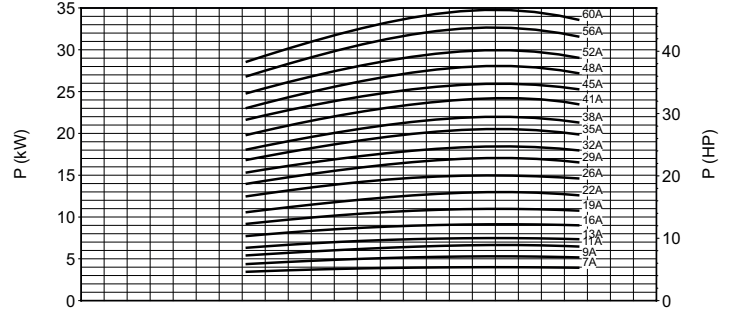
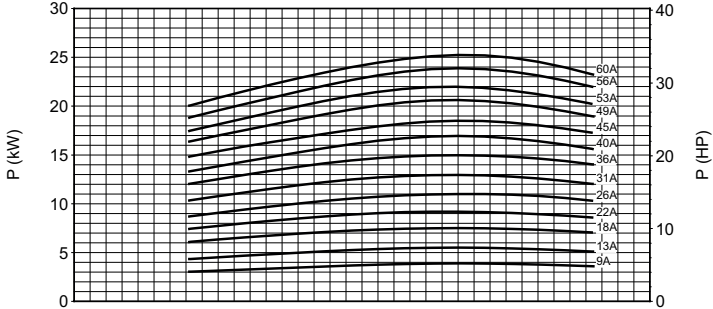
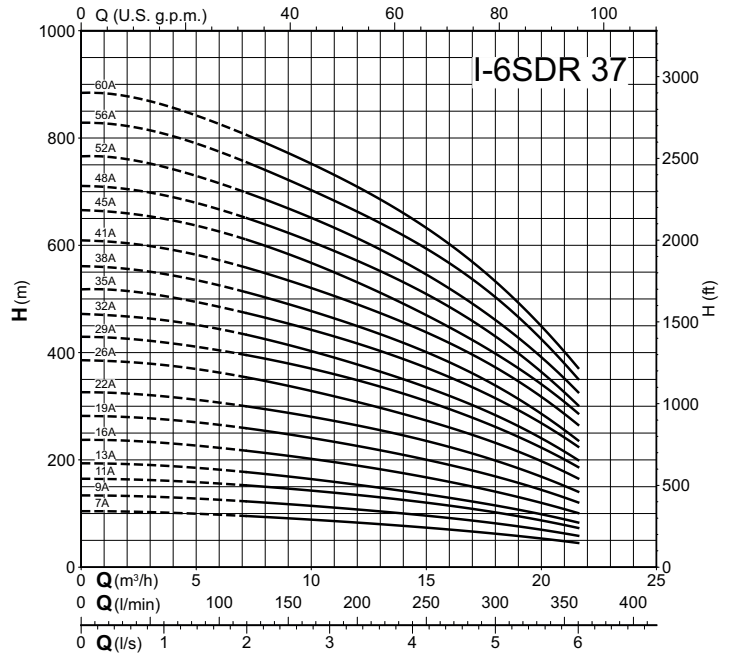
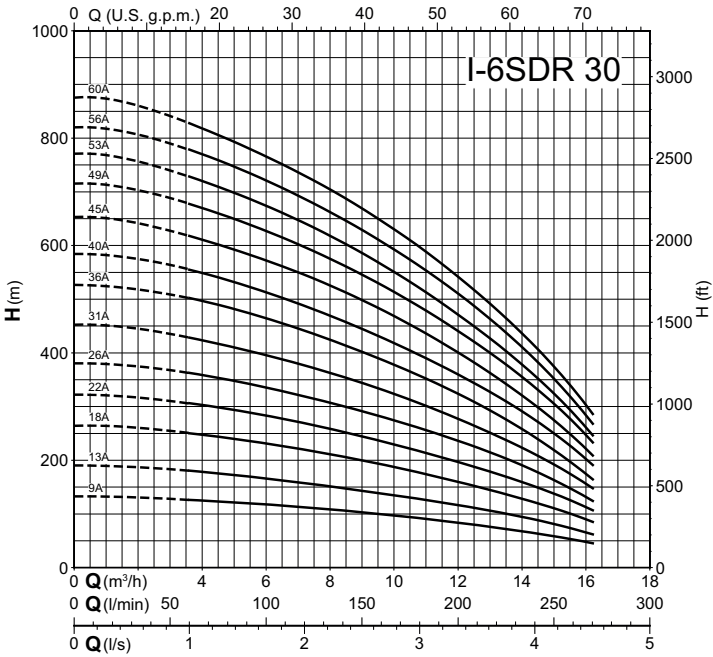

Coverage chart  $n \approx 2900$  rpm

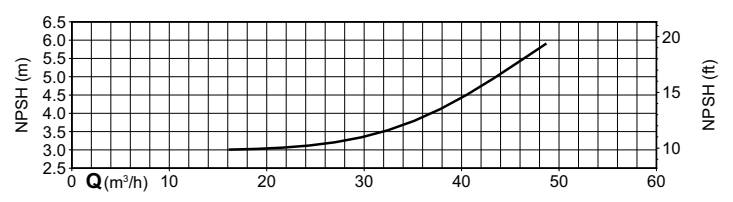
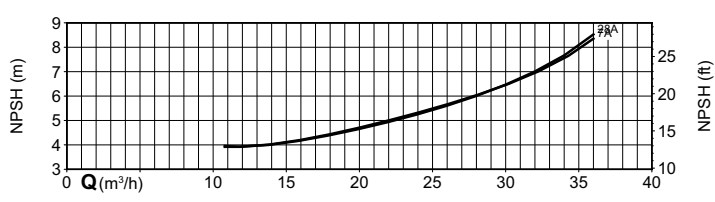
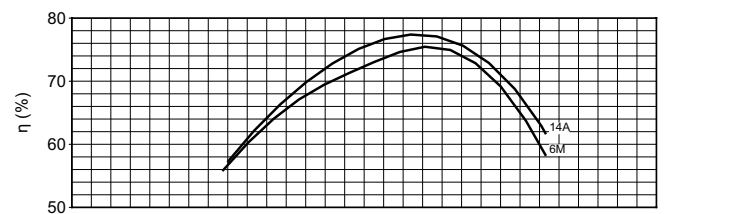
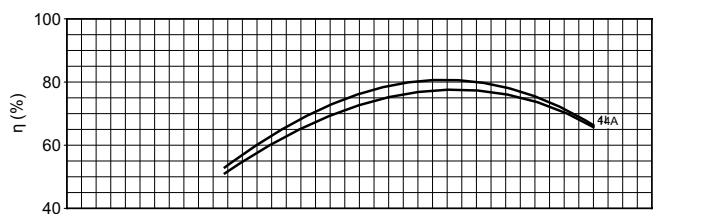
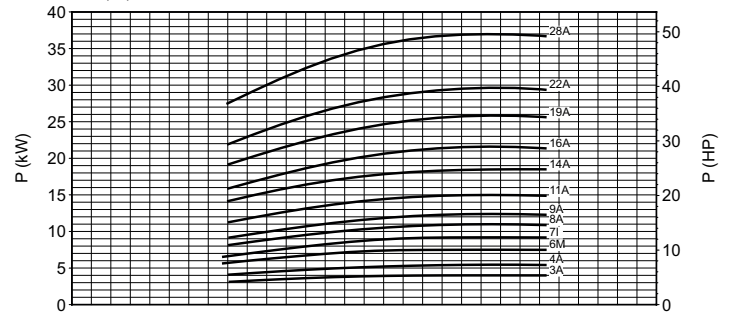
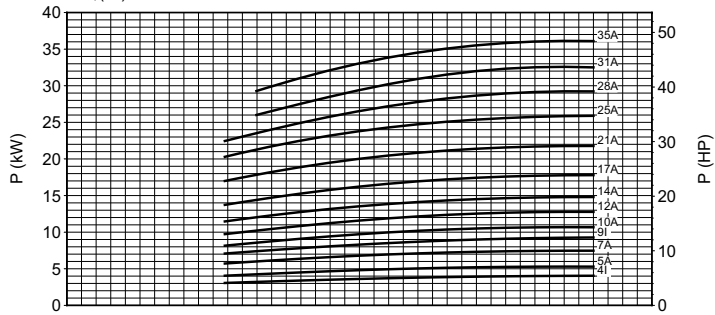
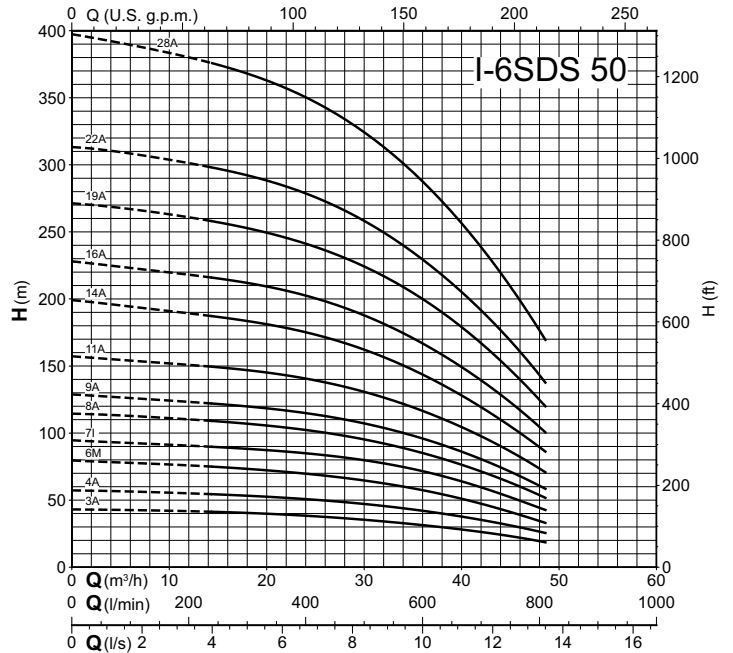
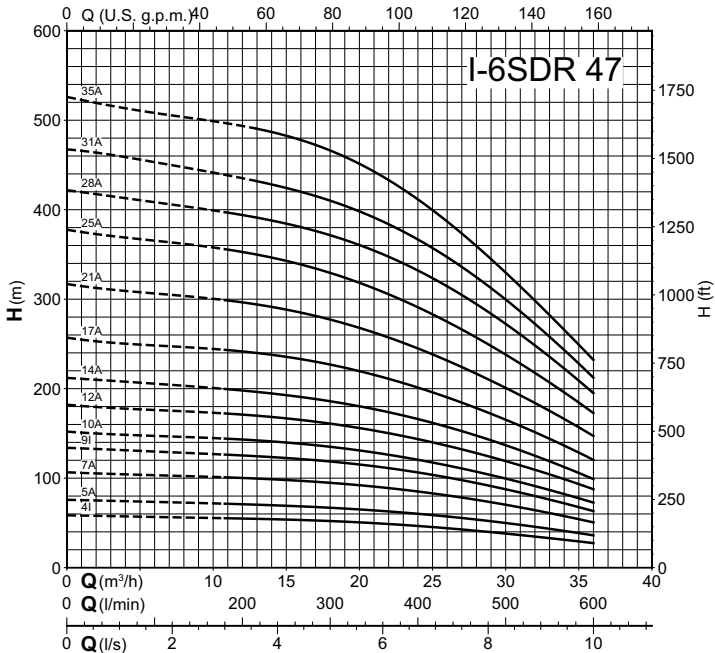

Coverage chart  $n \approx 2900$  rpm

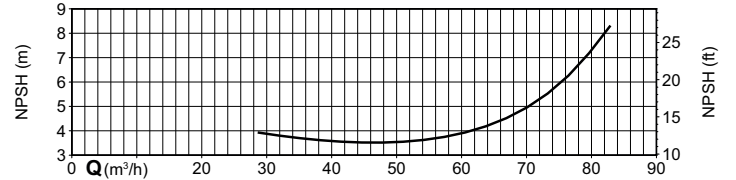
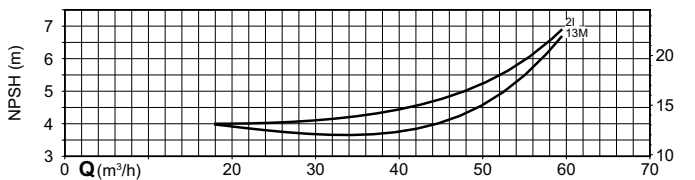
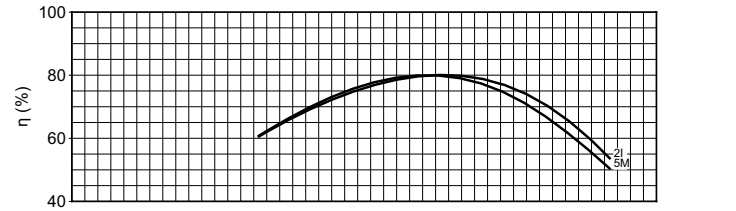
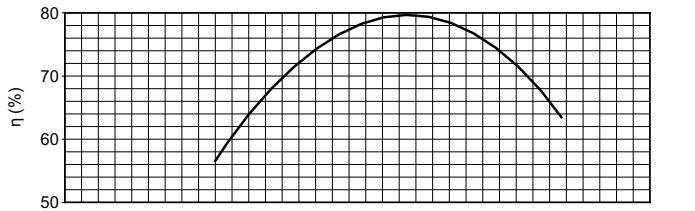
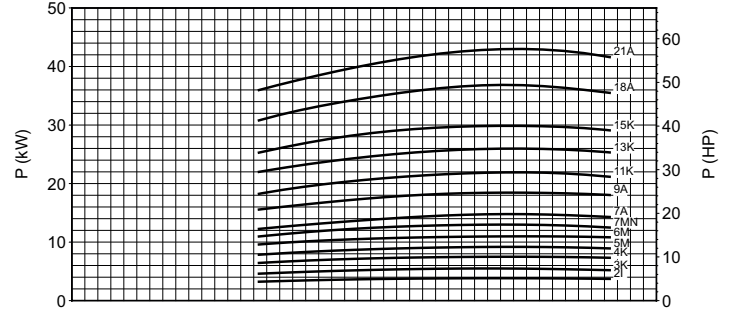
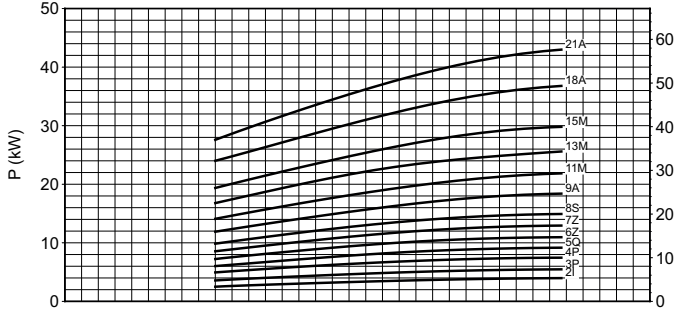
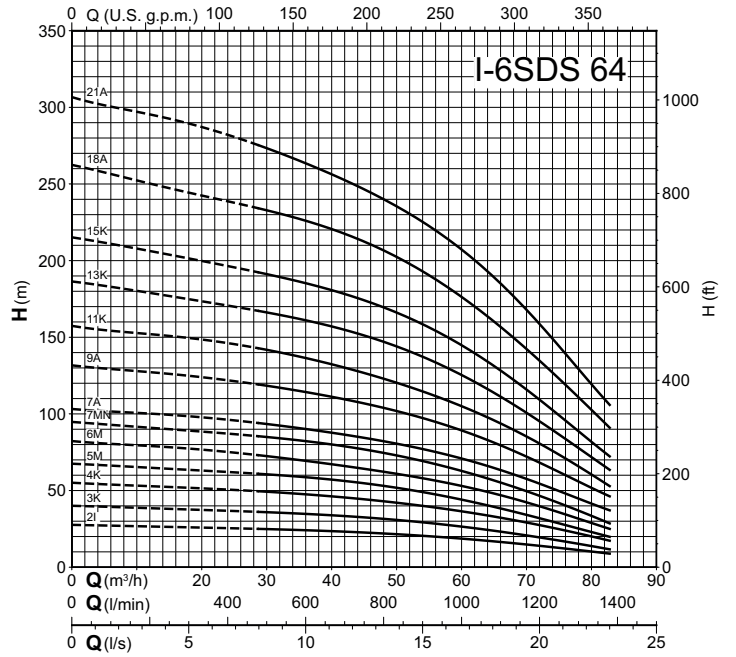
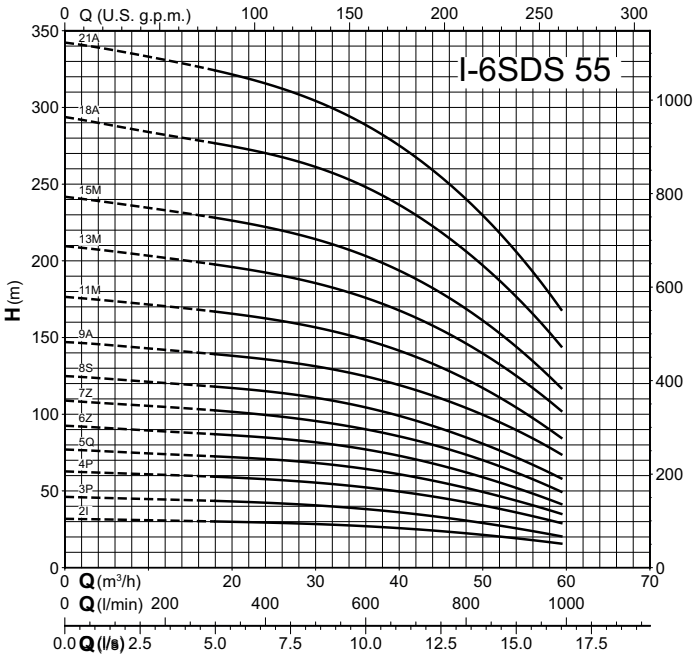

Coverage chart n ≈ 2900 rpm

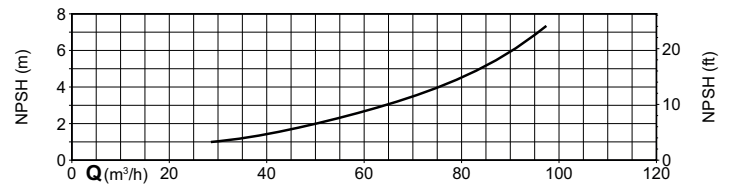
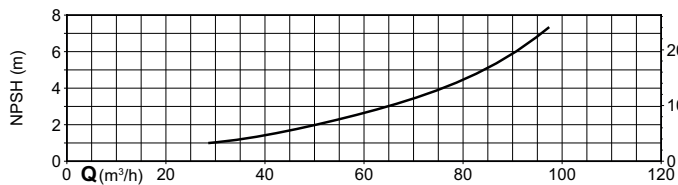
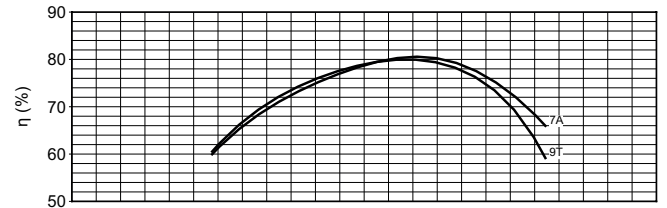
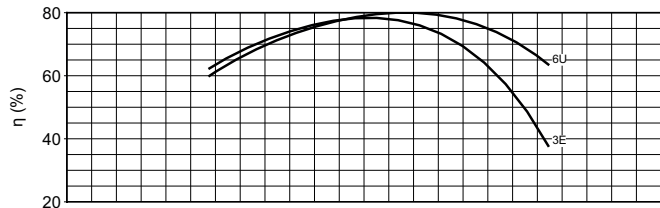
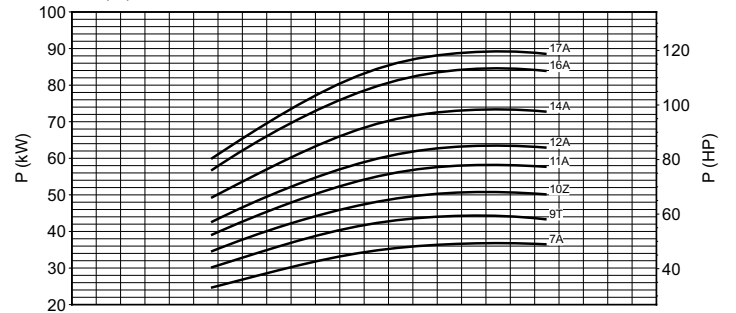
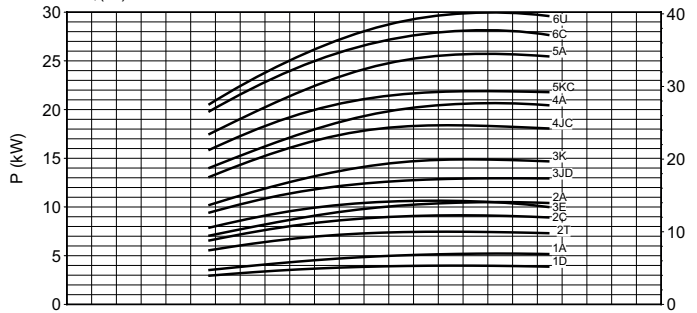
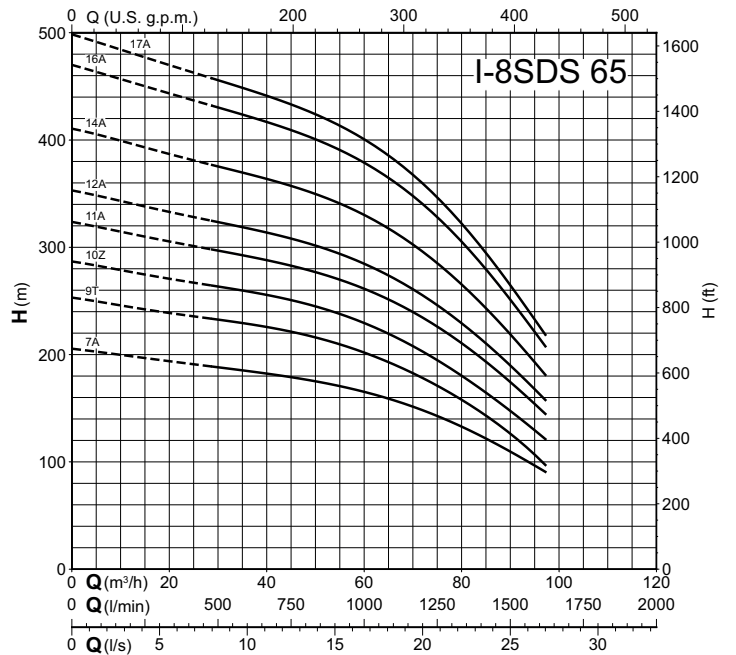
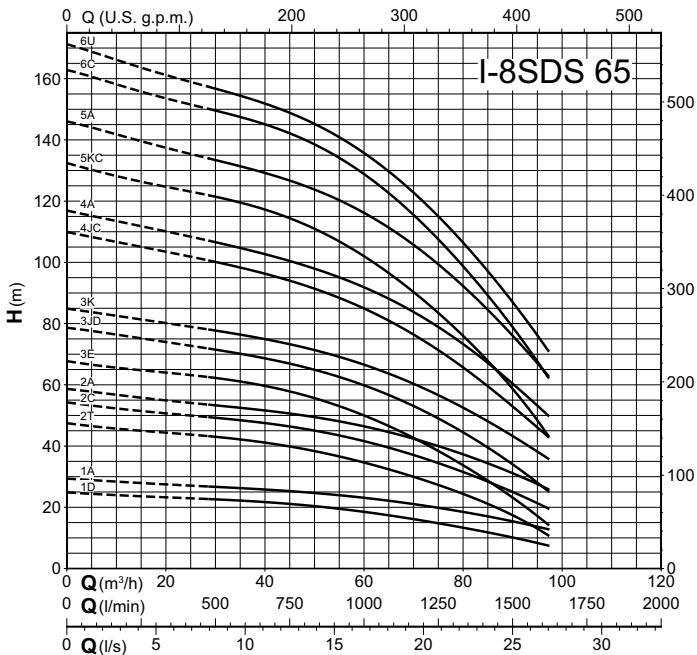

Coverage chart  $n \approx 2900$  rpm

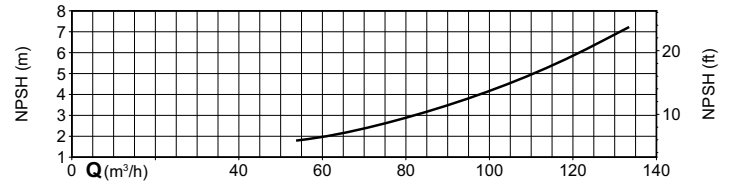
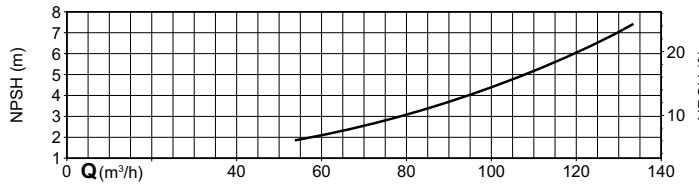
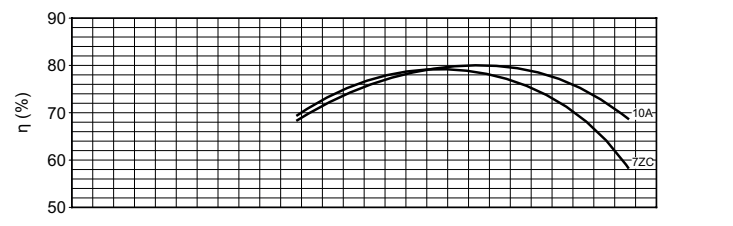
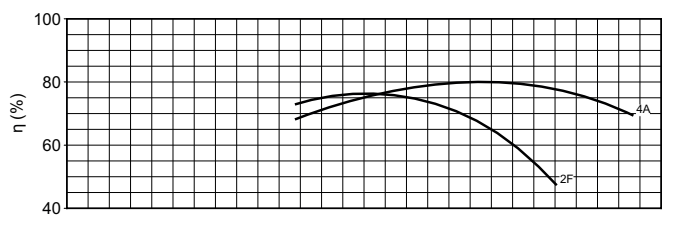
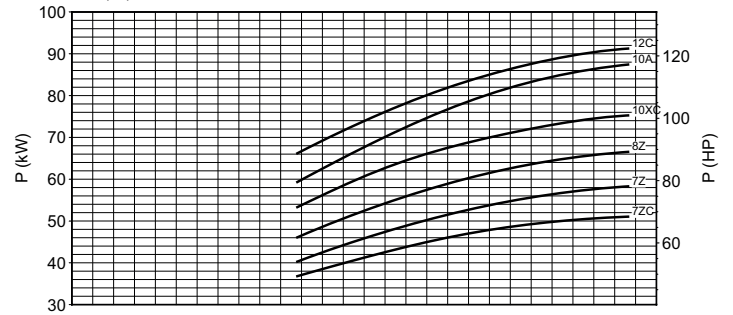
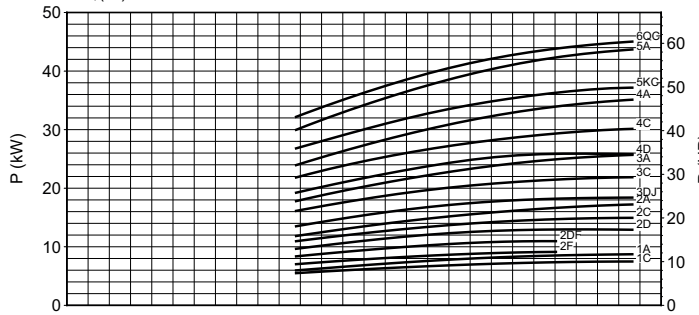
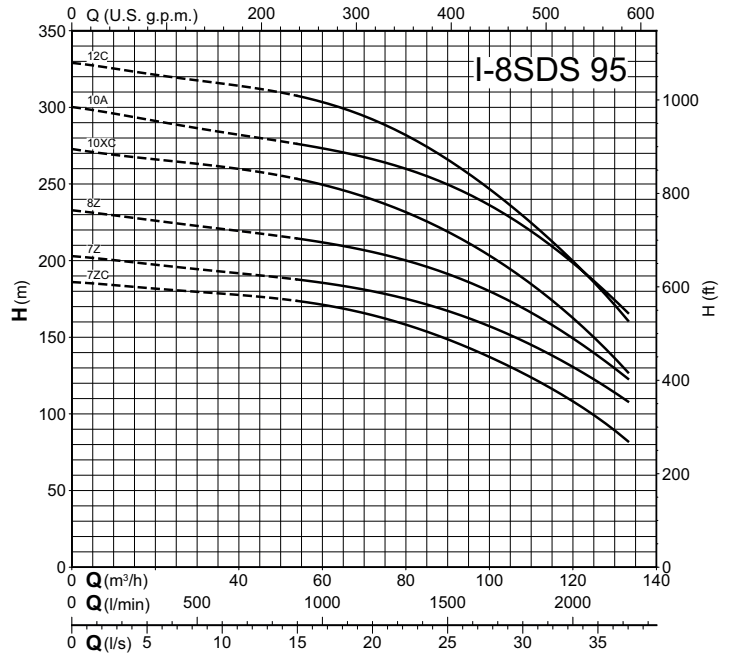
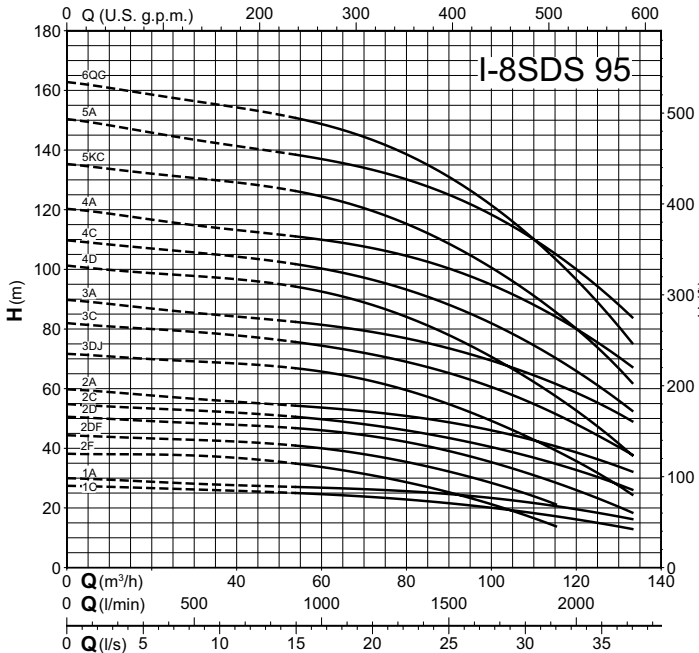

Coverage chart  $n \approx 2900$  rpm

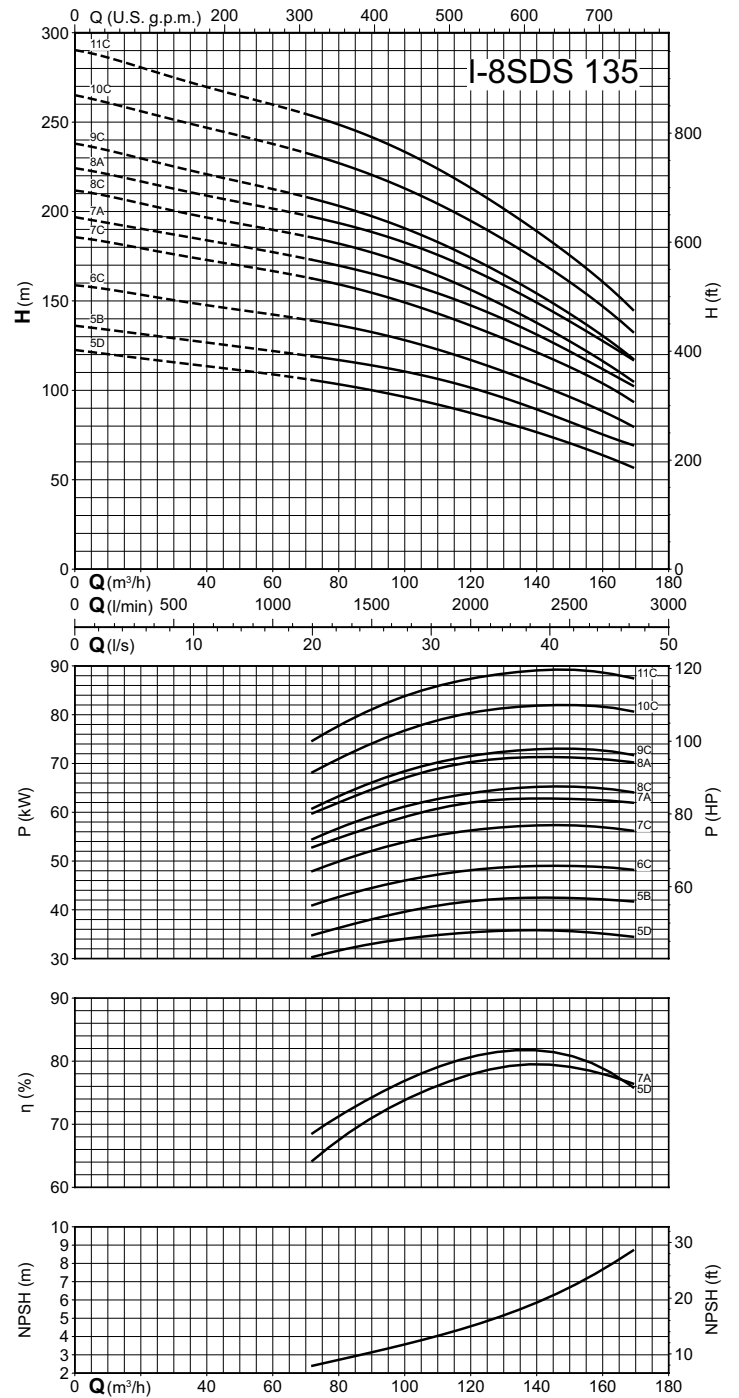
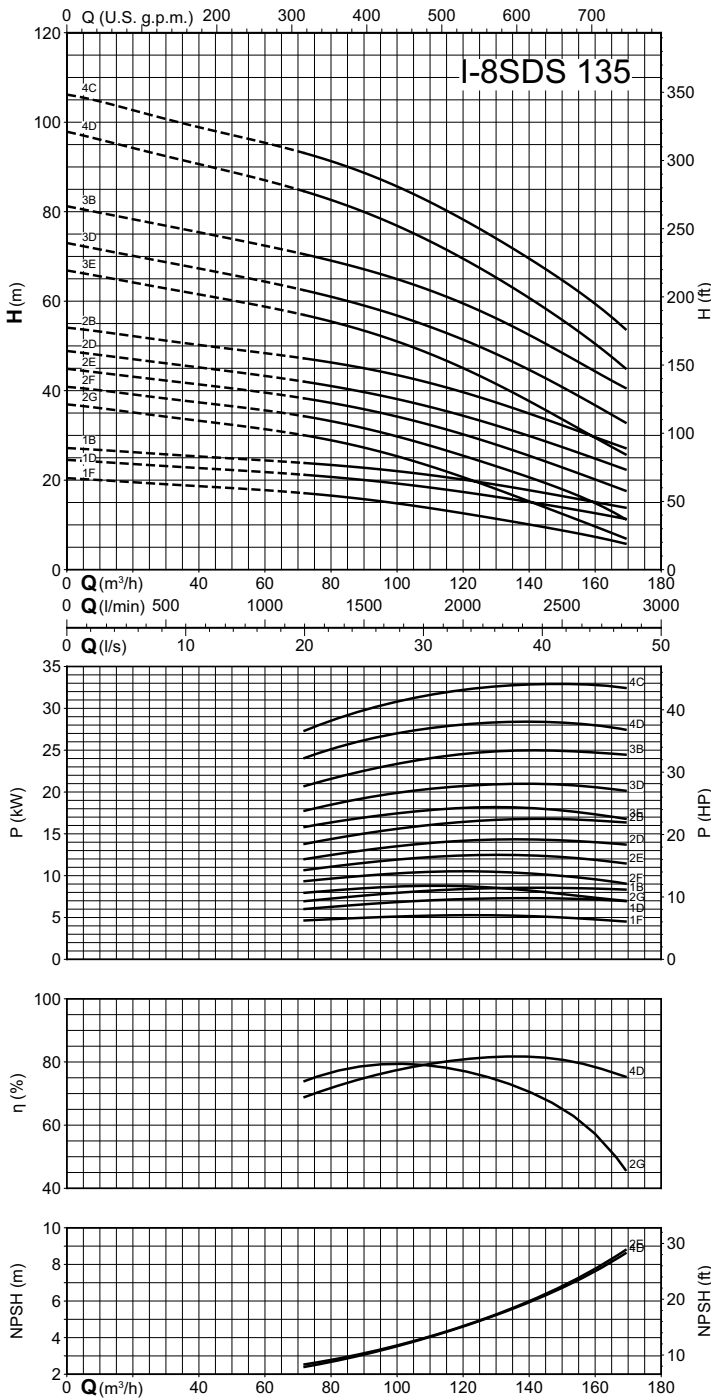

Coverage chart  $n \approx 2900$  rpm

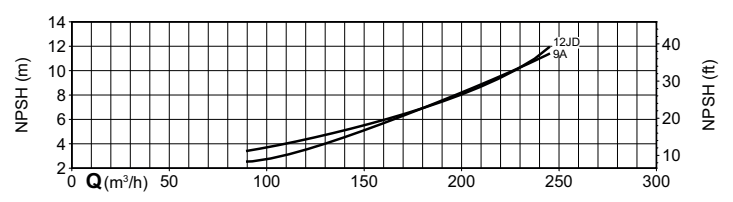
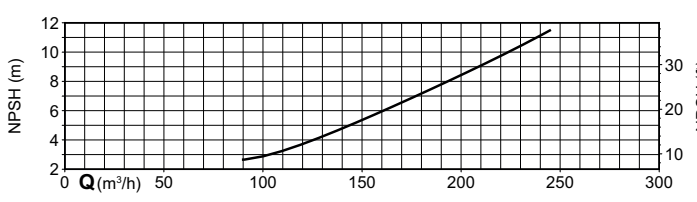
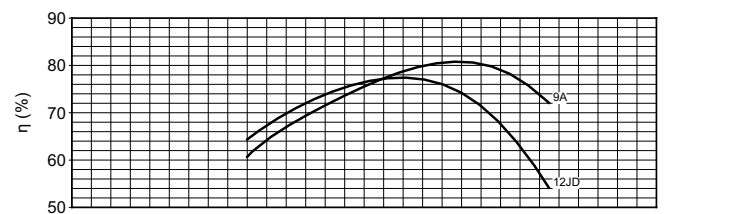
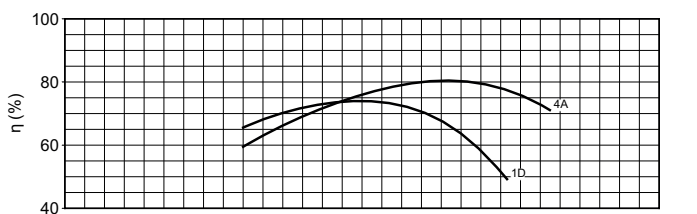
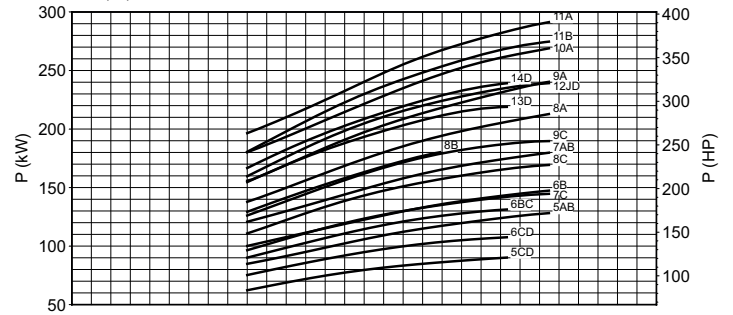
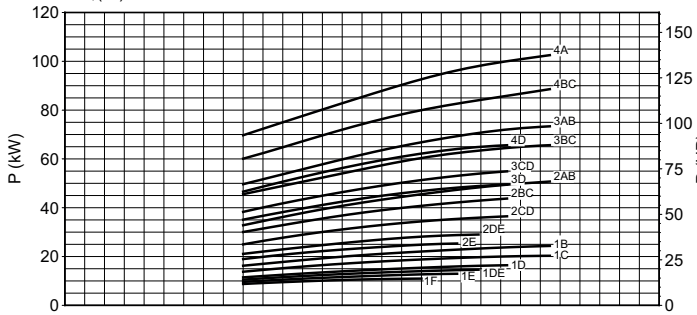
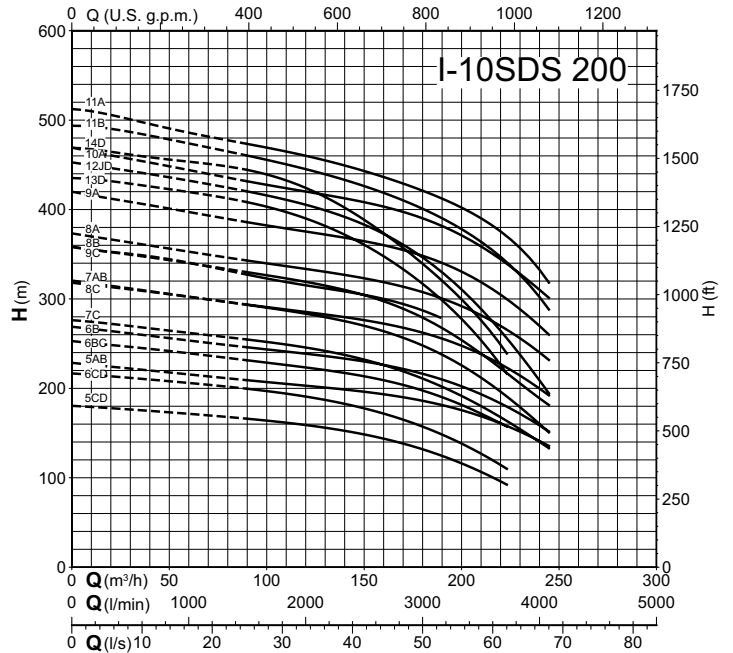
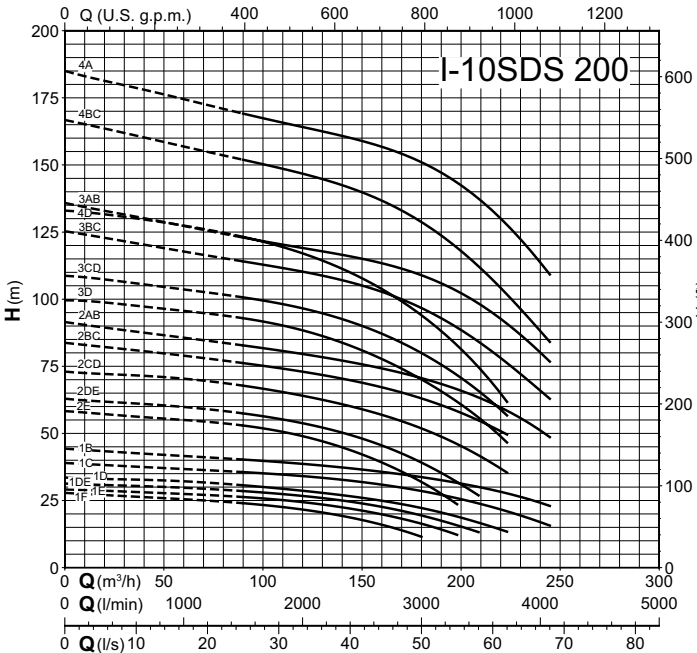

Coverage chart  $n \approx 2900$  rpm

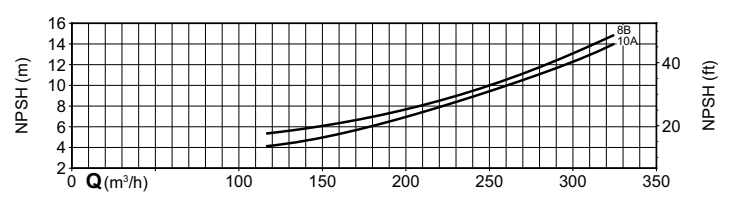
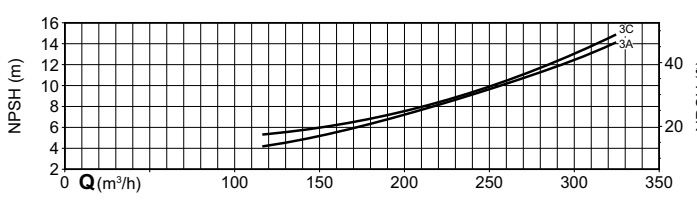
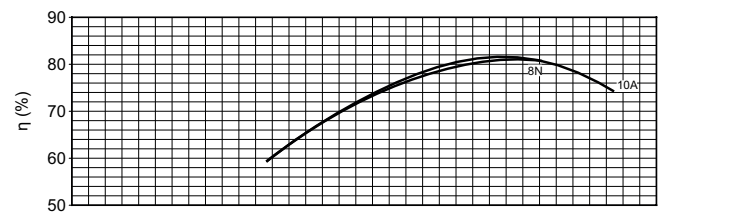
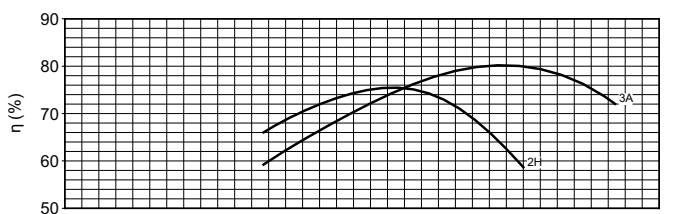
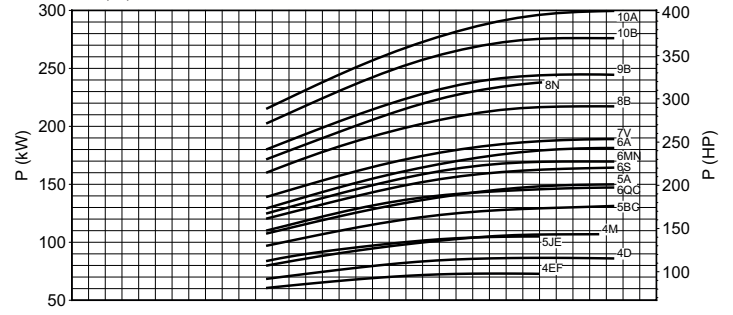
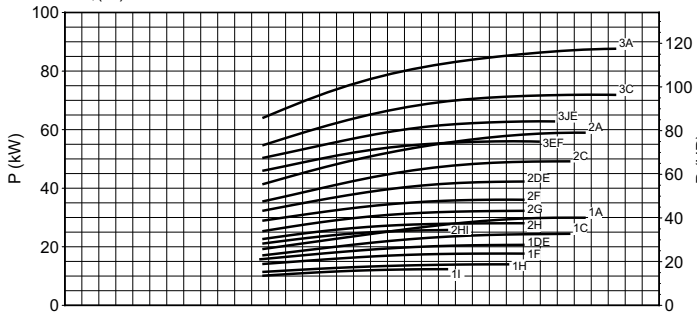
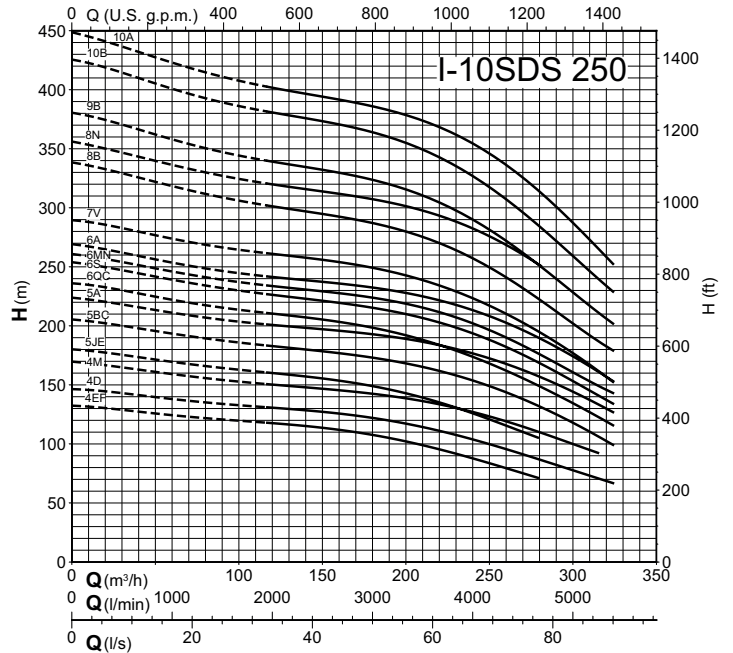
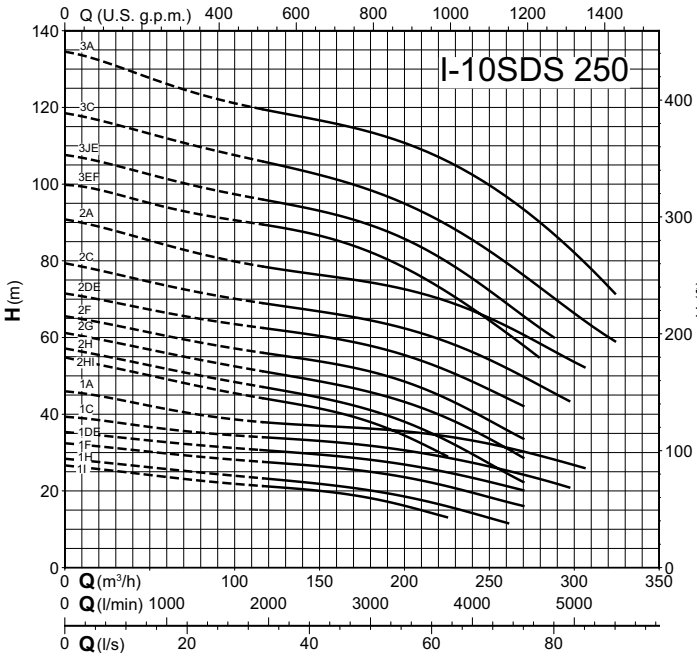

Coverage chart  $n \approx 2900$  rpm

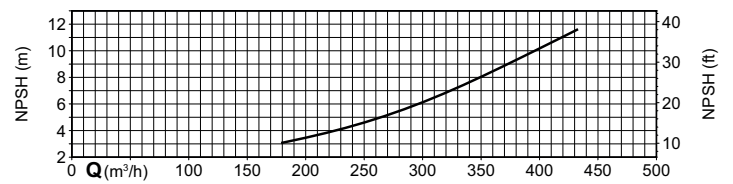
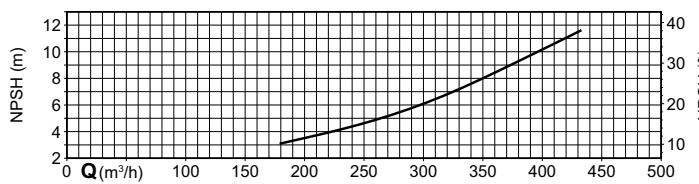
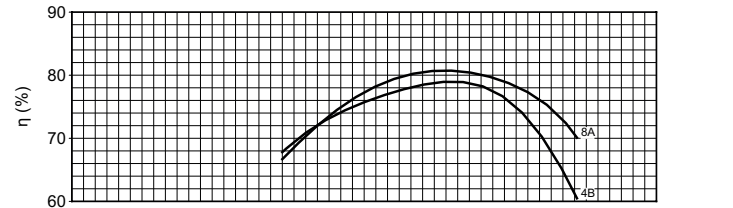
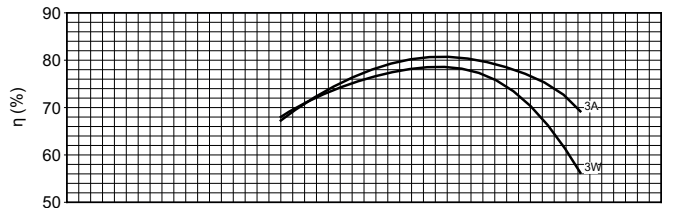
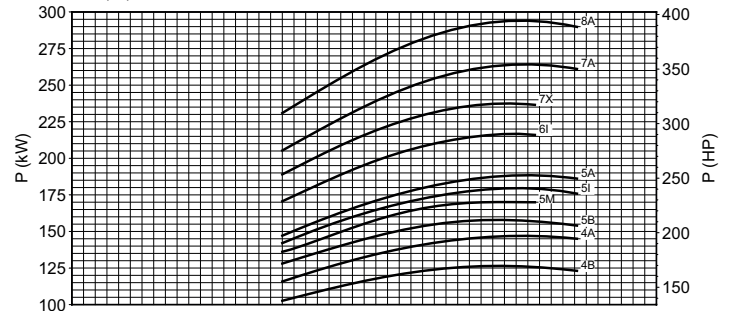
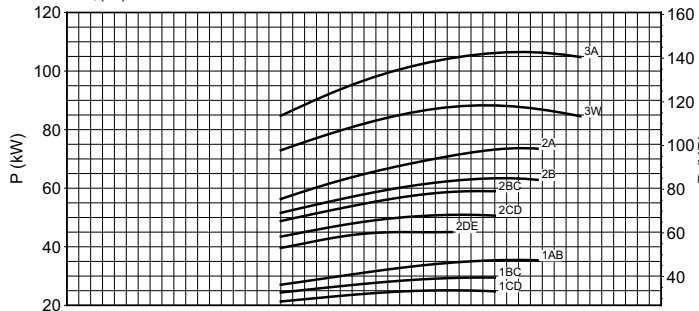
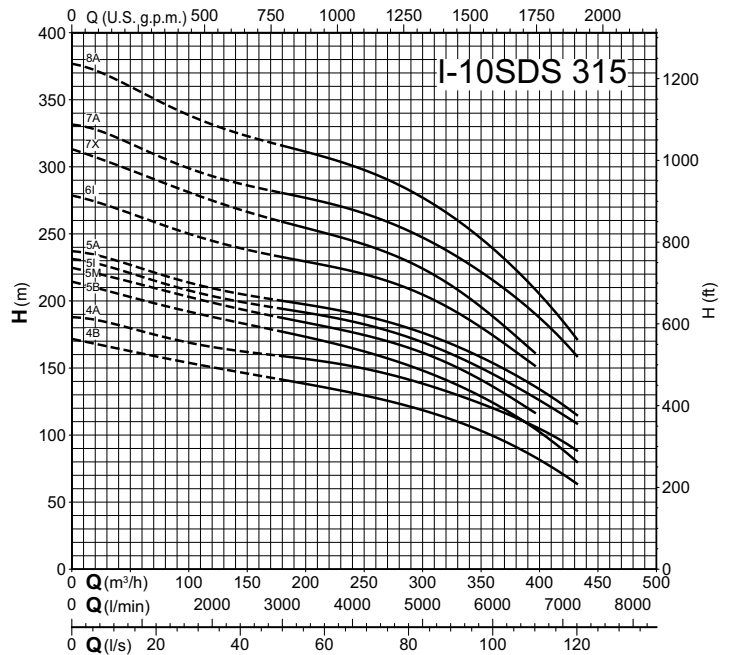
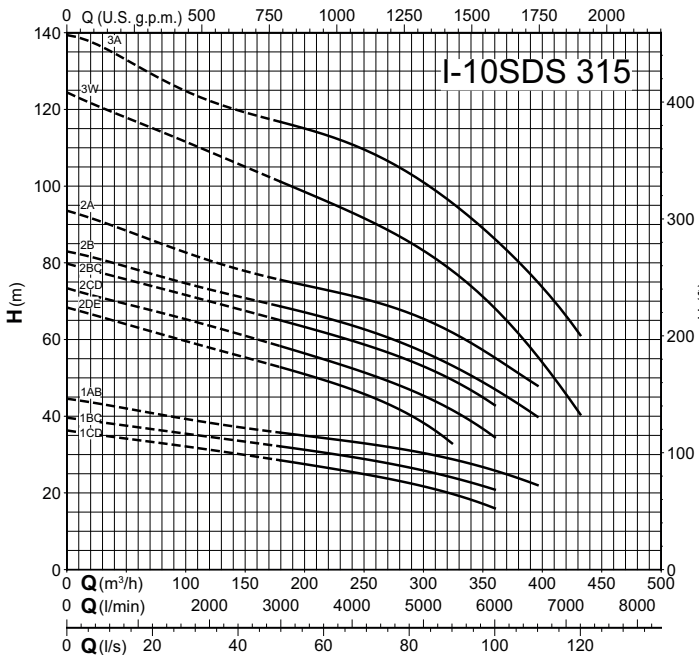

Coverage chart  $n \approx 2900$  rpm

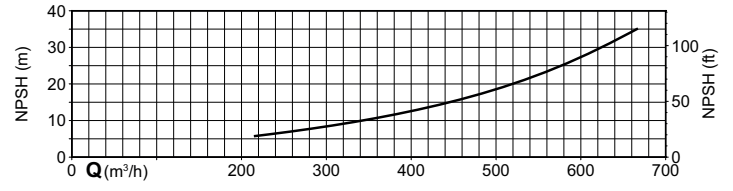
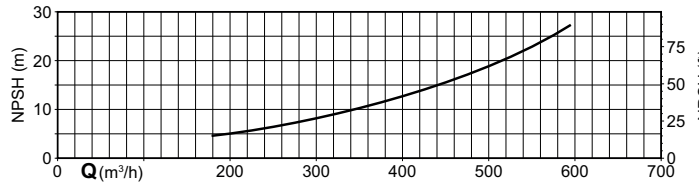
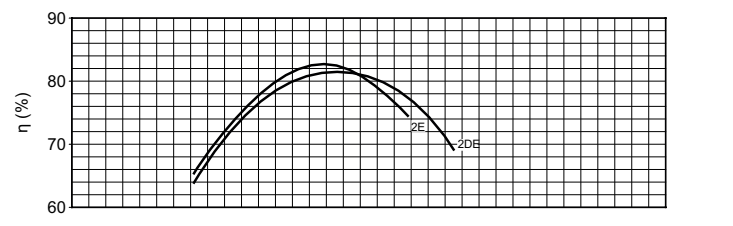
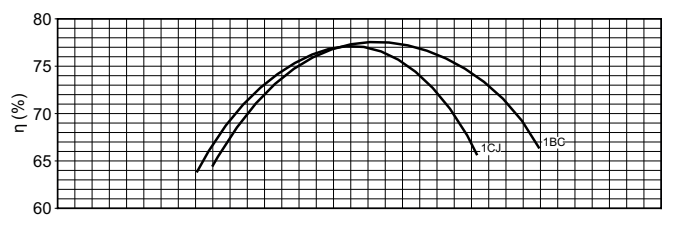
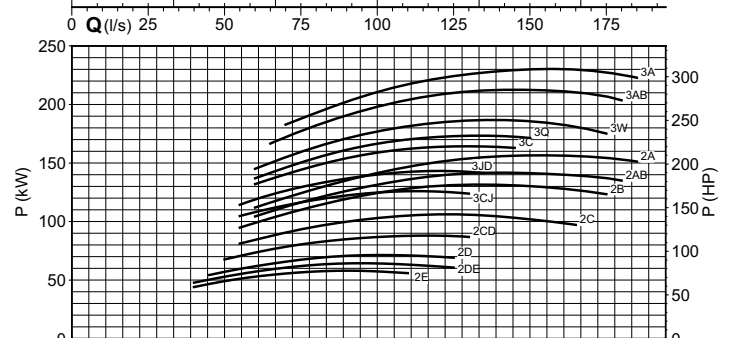
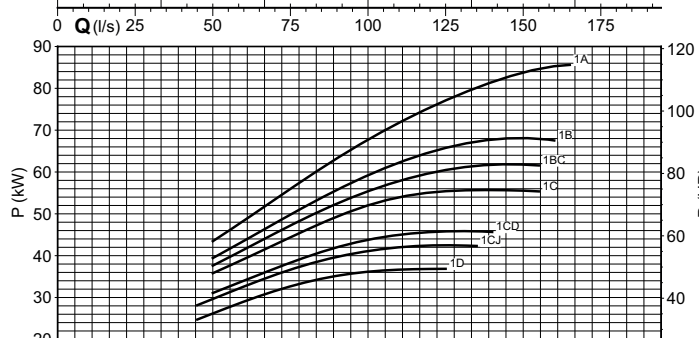
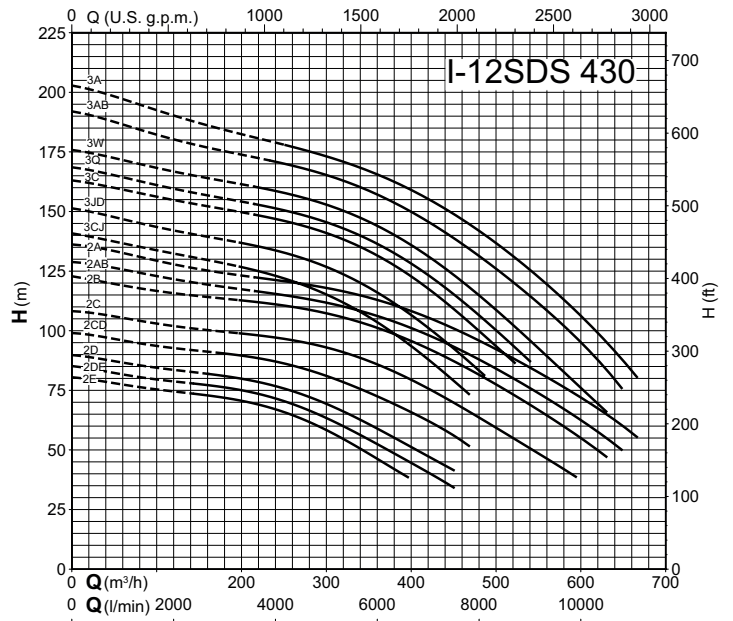
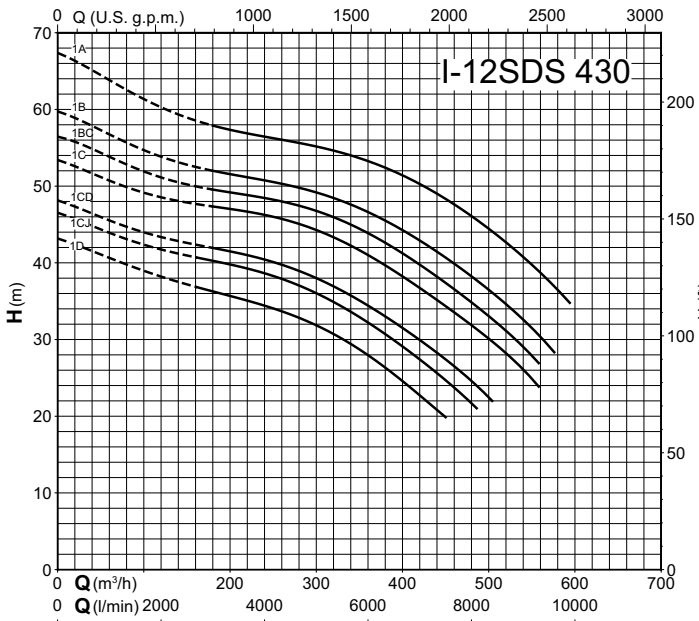

## Coverage chart $n \approx 2900$ rpm

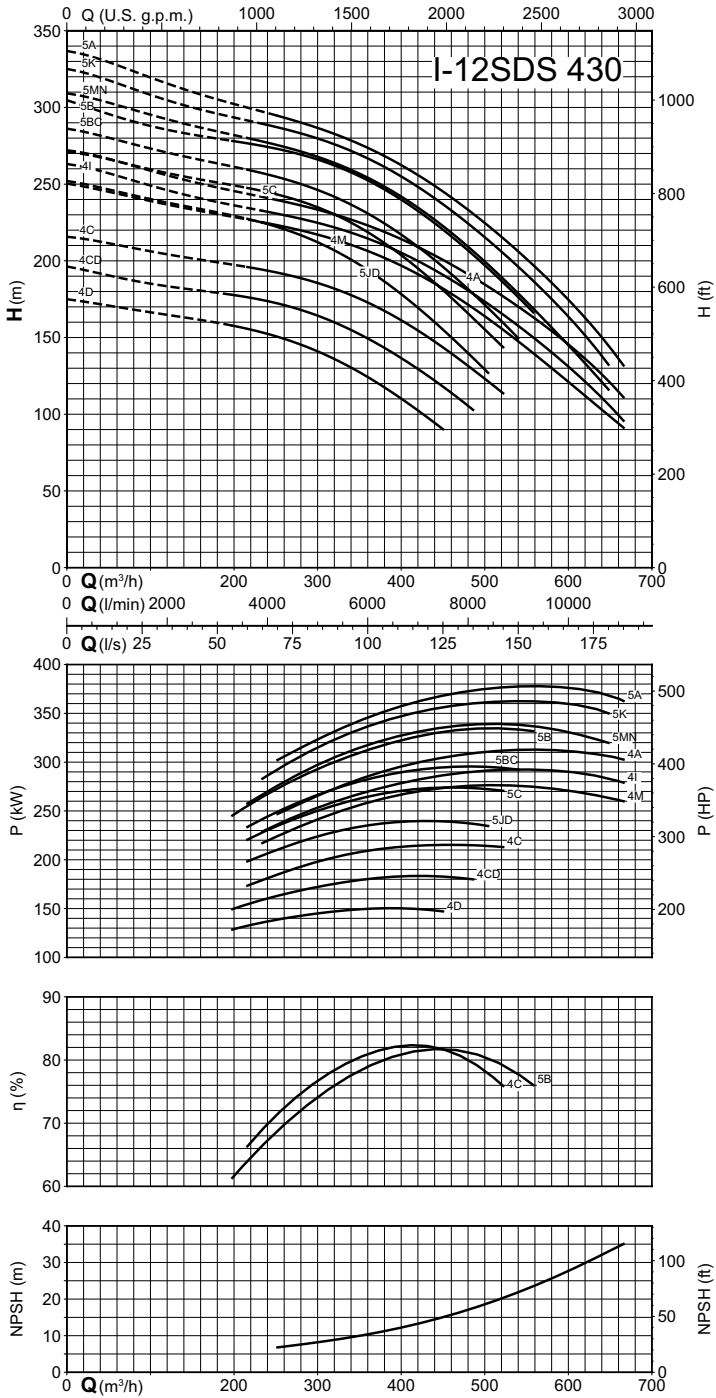

## Dimensions and weights

TYPE	mm				kg Weight
	DN2	f	l4	l5	
6SDS 35/3I 6SM	G3	674	145,5	150	31
6SDS 35/4I 6SM	G3	789	145,5	150	37
6SDS 35/6L 6SM	G3	1019	145,5	150	49
6SDS 35/7N 6SM	G3	1134	145,5	150	55
6SDS 35/8A 6SM	G3	1249	145,5	150	61
6SDS 35/10M 6SM	G3	1479	145,5	150	73
6SDS 35/11I 6SM	G3	1594	145,5	150	79
6SDS 35/12A 6SM	G3	1709	145,5	150	85
6SDS 35/14M 6SM	G3	1939	145,5	150	97
6SDS 35/15A 6SM	G3	2054	145,5	150	103
6SDS 35/16A 6SM	G3	2184	145,5	150	109
6SDS 35/17A 6SM	G3	2299	145,5	150	115
6SDS 35/19A 6SM	G3	2529	145,5	150	127
6SDS 35/21A 6SM	G3	2759	145,5	150	139
6SDS 35/22A 6SM	G3	2874	145,5	150	145
6SDS 35/24A 6SM	G3	3104	145,5	150	157
6SDS 35/25A 6SM	G3	3219	145,5	150	163
6SDS 35/27A 6SM	G3	3449	145,5	150	175
6SDS 35/30A 6SM	G3	3794	145,5	150	193
6SDS 35/32A 6SM	G3	4024	145,5	150	205

TYPE	mm				kg Weight
	DN2	f	l4	l5	
6SDS 45/2I 6SM	G3	559	145,5	150	25
6SDS 45/3N 6SM	G3	674	145,5	150	31
6SDS 45/3A 6SM	G3	674	145,5	150	31
6SDS 45/4N 6SM	G3	789	145,5	150	37
6SDS 45/5U 6SM	G3	904	145,5	150	43
6SDS 45/6P 6SM	G3	1019	145,5	150	49
6SDS 45/7L 6SM	G3	1134	145,5	150	55
6SDS 45/7A 6SM	G3	1134	145,5	150	55
6SDS 45/8A 6SM	G3	1249	145,5	150	61
6SDS 45/9A 6SM	G3	1364	145,5	150	67
6SDS 45/11I 6SM	G3	1594	145,5	150	79
6SDS 45/13I 6SM	G3	1824	145,5	150	91
6SDS 45/14A 6SM	G3	1939	145,5	150	97
6SDS 45/16A 6SM	G3	2169	145,5	150	109
6SDS 45/18A 6SM	G3	2399	145,5	150	121
6SDS 45/20A 6SM	G3	2629	145,5	150	133
6SDS 45/22A 6SM	G3	2859	145,5	150	145

TYPE	mm				kg Weight
	DN2	f	l4	l5	
6SDS 55/2A 6SM	G3	559	145,5	150	25
6SDS 55/3I 6SM	G3	674	145,5	150	31
6SDS 55/4A 6SM	G3	789	145,5	150	37
6SDS 55/5I 6SM	G3	904	145,5	150	43
6SDS 55/6I 6SM	G3	1019	145,5	150	49
6SDS 55/7I 6SM	G3	1134	145,5	150	55
6SDS 55/8I 6SM	G3	1249	145,5	150	61
6SDS 55/9A 6SM	G3	1364	145,5	150	67
6SDS 55/10A 6SM	G3	1479	145,5	150	73
6SDS 55/12N 6SM	G3	1709	145,5	150	85
6SDS 55/13A 6SM	G3	1824	145,5	150	91
6SDS 55/14A 6SM	G3	1939	145,5	150	97
6SDS 55/15A 6SM	G3	2054	145,5	150	103
6SDS 55/16A 6SM	G3	2169	145,5	150	109
6SDS 55/17A 6SM	G3	2284	145,5	150	115
6SDS 55/19A 6SM	G3	2514	145,5	150	127
6SDS 55/21A 6SM	G3	2744	145,5	150	139
6SDS 55/23A 6SM	G3	2974	145,5	150	151

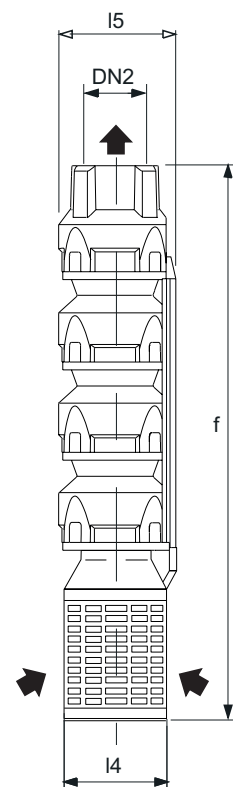

**MOTORS TO CONNECT**  
 STANDARD coupling flange:  
 (6SM) NEMA 6, 6" motor;  
 (8SM) NEMA 8, 8", 10" motor;  
 (12SM) C 12 Coupling, 12", 14" motor;

## Dimensions and weights

TYPE	DN2	mm			kg Weight
		f	l4	l5	
8SDS 65/1D 6SM	G5	560	192	203	35
8SDS 65/1A 6SM	G5	560	192	203	35
8SDS 65/2T 6SM	G5	695	192	203	45.5
8SDS 65/2C 6SM	G5	695	192	203	45.5
8SDS 65/2A 6SM	G5	695	192	203	45.5
8SDS 65/3E 6SM	G5	830	192	203	56
8SDS 65/3JD 6SM	G5	830	192	203	56
8SDS 65/3K 6SM	G5	830	192	203	56
8SDS 65/4JC 6SM	G5	965	192	203	66.5
8SDS 65/4A 6SM	G5	965	192	203	67
8SDS 65/5KC 6SM	G5	1100	192	203	77
8SDS 65/5A 6SM	G5	1100	192	203	77.5
8SDS 65/6U 6SM	G5	1235	192	203	89
8SDS 65/6U 8SM	G5	1260.5	192	203	87.5
8SDS 65/6C 6SM	G5	1235	192	203	87.5
8SDS 65/6C 8SM	G5	1260.5	192	203	87.5
8SDS 65/7A 6SM	G5	1370	192	203	98
8SDS 65/7A 8SM	G5	1395.5	192	203	98
8SDS 65/9T 6SM	G5	1640	192	203	118.5
8SDS 65/9T 8SM	G5	1665.5	192	203	119.5
8SDS 65/10Z 8SM	G5	1800.5	192	203	129.5
8SDS 65/11A 8SM	G5	1935.5	192	203	140
8SDS 65/12A 8SM	G5	2070.5	192	203	150.5
8SDS 65/14A 8SM	G5	2340.5	192	203	171.5
8SDS 65/16A 8SM	G5	2610.5	192	203	192.5
8SDS 65/17A 8SM	G5	2745.5	192	203	203

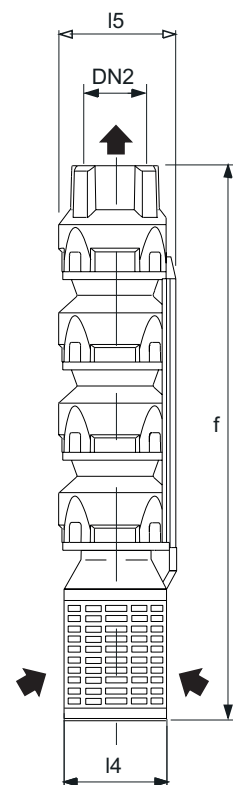

TYPE	DN2	mm			kg Weight
		f	l4	l5	
8SDS 95/1C 6SM	G5	565	192	203	36
8SDS 95/1A 6SM	G5	565	192	203	36
8SDS 95/2F 6SM	G5	705	192	203	47
8SDS 95/2DF 6SM	G5	705	192	203	47
8SDS 95/2D 6SM	G5	705	192	203	47
8SDS 95/2C 6SM	G5	705	192	203	47
8SDS 95/2A 6SM	G5	705	192	203	47
8SDS 95/3DJ 6SM	G5	845	192	203	58
8SDS 95/3C 6SM	G5	845	192	203	58
8SDS 95/3A 6SM	G5	845	192	203	58
8SDS 95/4D 6SM	G5	985	192	203	69
8SDS 95/4C 6SM	G5	985	192	203	69
8SDS 95/4C 8SM	G5	1010.5	192	203	69.5
8SDS 95/4A 6SM	G5	985	192	203	69
8SDS 95/4A 8SM	G5	1010.5	192	203	69.5
8SDS 95/5KC 6SM	G5	1125	192	203	80
8SDS 95/5KC 8SM	G5	1150.5	192	203	80.5
8SDS 95/5A 6SM	G5	1125	192	203	80
8SDS 95/5A 8SM	G5	1150.5	192	203	80.5
8SDS 95/6QC 6SM	G5	1125	192	203	91
8SDS 95/6QC 8SM	G5	1290.5	192	203	91.5
8SDS 95/7ZC 8SM	G5	1430.5	192	203	102.5
8SDS 95/7Z 8SM	G5	1430.5	192	203	102.5
8SDS 95/8Z 8SM	G5	1570.5	192	203	113.5
8SDS 95/10XC 8SM	G5	1850.5	192	203	135.5
8SDS 95/10A 8SM	G5	1850.5	192	203	135.5
8SDS 95/12C 8SM	G5	2130.5	192	203	157.5

### MOTORS TO CONNECT

STANDARD coupling flange:

(6SM) NEMA 6, 6" motor;

(8SM) NEMA 8, 8", 10" motor;

(12SM) C 12 Coupling, 12", 14" motor;

## Dimensions and weights

TYPE	DN2	mm			kg Weight
		f	l4	l5	
8SDS 135/1F 6SM	G5	565	192	203	36
8SDS 135/1D 6SM	G5	565	192	203	36
8SDS 135/1B 6SM	G5	565	192	203	36
8SDS 135/2G 6SM	G5	705	192	203	47
8SDS 135/2F 6SM	G5	705	192	203	47
8SDS 135/2E 6SM	G5	705	192	203	47
8SDS 135/2D 6SM	G5	705	192	203	47
8SDS 135/2B 6SM	G5	705	192	203	47
8SDS 135/3E 6SM	G5	845	192	203	58
8SDS 135/3D 6SM	G5	845	192	203	58
8SDS 135/3B 6SM	G5	845	192	203	58
8SDS 135/4D 6SM	G5	985	192	203	69
8SDS 135/4D 8SM	G5	1010.5	192	203	72
8SDS 135/4C 6SM	G5	985	192	203	69
8SDS 135/4C 8SM	G5	1010.5	192	203	72
8SDS 135/5D 6SM	G5	1125	192	203	80
8SDS 135/5D 8SM	G5	1150.5	192	203	83
8SDS 135/5B 6SM	G5	1125	192	203	83
8SDS 135/5B 8SM	G5	1150.5	192	203	83
8SDS 135/6C 8SM	G5	1290.5	192	203	94
8SDS 135/7C 8SM	G5	1430.5	192	203	105
8SDS 135/7A 8SM	G5	1430.5	192	203	105
8SDS 135/8C 8SM	G5	1570.5	192	203	116
8SDS 135/8A 8SM	G5	1570.5	192	203	116
8SDS 135/9C 8SM	G5	1710.5	192	203	127
8SDS 135/10C 8SM	G5	1850.5	192	203	138
8SDS 135/11C 8SM	G5	1990.5	192	203	149

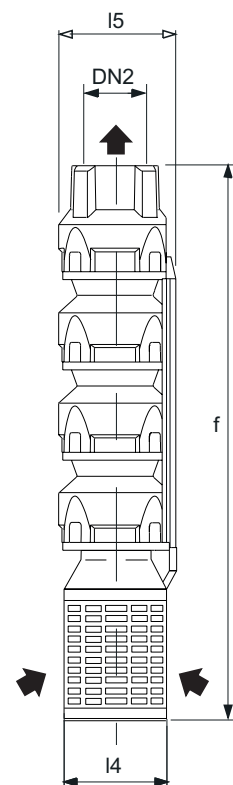

**MOTORS TO CONNECT**  
 STANDARD coupling flange:  
 (6SM) NEMA 6, 6" motor;  
 (8SM) NEMA 8, 8", 10" motor;  
 (12SM) C 12 Coupling, 12", 14" motor;

## Dimensions and weights

TYPE	DN2	mm			kg Weight
		f	l4	l5	
8SDR 35/11A 6SM	G3	1198	188	196	79
8SDR 35/13A 6SM	G3	1314	188	196	88
8SDR 35/15A 6SM	G3	1430	188	196	97
8SDR 35/15A 8SM	G3	1455.5	188	197,5	97
8SDR 35/17A 6SM	G3	1546	188	196	106
8SDR 35/17A 8SM	G3	1571.5	188	197,5	106
8SDR 35/19A 6SM	G3	1662	188	196	115
8SDR 35/19A 8SM	G3	1687.5	188	197,5	115
8SDR 35/23A 6SM	G3	1894	188	196	133
8SDR 35/23A 8SM	G3	1919.5	188	197,5	133
8SDR B35/27A 8SM	G3	2253.5	188	197,5	157
8SDR B35/31A 8SM	G3	2485.5	188	197,5	175
8SDR B35/35A 8SM	G3	2717.5	188	197,5	193

TYPE	DN2	mm			kg Weight
		f	l4	l5	
8SDR 40/6A 6SM	G3	968	188	196	56.5
8SDR 40/7A 6SM	G3	1038	188	196	61
8SDR 40/8A 6SM	G3	1108	188	196	65.5
8SDR 40/9A 6SM	G3	1178	188	196	70
8SDR 40/9A 8SM	G3	1215.5	188	197,5	70
8SDR 40/11A 6SM	G3	1318	188	196	81.4
8SDR 40/11A 8SM	G3	1355.5	188	197,5	79
8SDR 40/13A 6SM	G3	1458	188	196	86
8SDR 40/13A 8SM	G3	1495.5	188	197,5	88
8SDR 40/15A 8SM	G3	1565.5	188	197,5	97
8SDR 40/17A 8SM	G3	1705.5	188	197,5	106
8SDR 40/19A 8SM	G3	1845.5	188	197,5	115
8SDR B40/21A 8SM	G3	2157.5	188	197,5	130
8SDR B40/23A 8SM	G3	2297.5	188	197,5	139
8SDR B40/25A 8SM	G3	2437.5	188	197,5	148
8SDR B40/28A 8SM	G3	2647.5	188	197,5	161.5
8SDR B40/30A 8SM	G3	2787.5	188	197,5	200.5

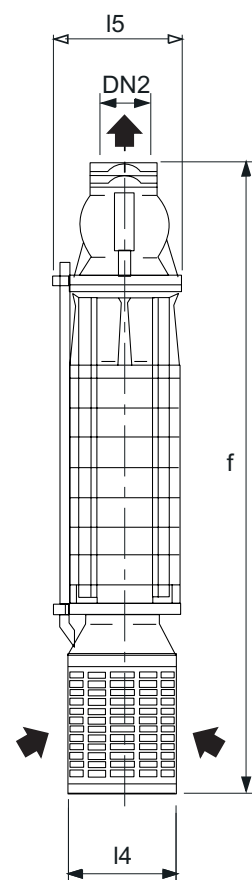

**MOTORS TO CONNECT**  
 STANDARD coupling flange:  
 (6SM) NEMA 6, 6" motor;  
 (8SM) NEMA 8, 8", 10" motor;  
 (12SM) C 12 Coupling, 12", 14" motor;

## Dimensions and weights

TYPE	DN2	mm								kg Weight
		de	dk	f	j4	l4	l5	s	z	
10SDS 50/1H 6SM	150	234	206	680	170.5	240	250	16	6	73
10SDS 50/1F 6SM	150	234	206	680	170.5	240	250	16	6	73
10SDS 50/1D 6SM	150	234	206	680	170.5	240	250	16	6	73
10SDS 50/1B 6SM	150	234	206	680	170.5	240	250	16	6	73
10SDS 50/2G 6SM	150	234	206	845	170.5	240	250	16	6	91
10SDS 50/2E 6SM	150	234	206	845	170.5	240	250	16	6	91
10SDS 50/2CD 6SM	150	234	206	845	170.5	240	250	16	6	91
10SDS 50/2B 6SM	150	234	206	845	170.5	240	250	16	6	91
10SDS 50/2B 8SM	150	234	206	873.5	170.5	240	250	16	6	89
10SDS 50/3D 6SM	150	234	206	1035.5	170.5	240	250	16	6	109
10SDS 50/3D 8SM	150	234	206	1038.5	170.5	240	250	16	6	107
10SDS 50/3B 6SM	150	234	206	1035.5	170.5	240	250	16	6	109
10SDS 50/3B 8SM	150	234	206	1038.5	170.5	240	250	16	6	107
10SDS 50/4CD 8SM	150	234	206	1203.5	170.5	240	250	16	6	125
10SDS 50/4B 8SM	150	234	206	1203.5	170.5	240	250	16	6	125
10SDS 50/5CD 8SM	150	234	206	1368.5	170.5	240	250	16	6	143
10SDS 50/5B 8SM	150	234	206	1368.5	170.5	240	250	16	6	143
10SDS 50/6C 8SM	150	234	206	1533.5	170.5	240	250	16	6	161
10SDS 50/7CD 8SM	150	234	206	1698.5	170.5	240	250	16	6	179
10SDS 50/8C 8SM	150	234	206	1863.5	170.5	240	250	16	6	197
10SDS 50/8B 8SM	150	234	206	1863.5	170.5	240	251	16	6	197
10SDS 50/9BC 8SM	150	234	206	2028.5	170.5	240	251	16	6	215
10SDS 50/10B 8SM	150	234	206	2193.5	170.5	240	251	16	6	224
10SDS 50/11B 8SM	150	234	206	2358.5	170.5	240	251	16	6	236
10SDS 50/12JC 8SM	150	234	206	2523.5	170.5	240	251	16	6	258
10SDS 50/12JC 12SM	150	234	206	2644	170.5	290	296	16	6	296
10SDS 50/13B 12SM	150	234	206	2809	170.5	290	296	16	6	314
10SDS 50/13B 8SM	150	234	206	2688.5	170.5	240	251	16	6	280
10SDS 50/14B 12SM	150	234	206	2974	170.5	290	296	16	6	332
10SDS 50/15B 12SM	150	234	206	3139	170.5	290	296	16	6	350

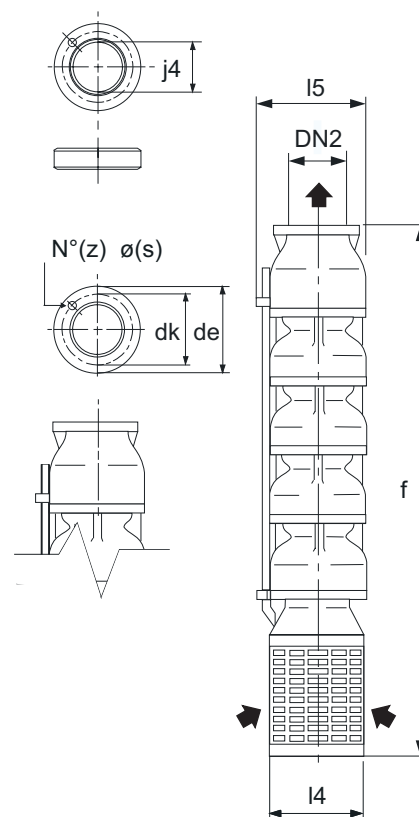

TYPE	DN2	mm								kg Weight
		de	dk	f	j4	l4	l5	s	z	
10SDS 55/2B 6SM	150	234	206	845	170.5	240	250	16	6	91
10SDS 55/2B 8SM	150	234	206	873.5	170.5	240	250	16	6	89
10SDS 55/2A 6SM	150	234	206	845	170.5	240	250	16	6	91
10SDS 55/2A 8SM	150	234	206	873.5	170.5	240	250	16	6	89
10SDS 55/3C 6SM	150	234	206	1035.5	170.5	240	250	16	6	109
10SDS 55/3C 8SM	150	234	206	1038.5	170.5	240	250	16	6	107
10SDS 55/3K 6SM	150	234	206	1035.5	170.5	240	250	16	6	109
10SDS 55/3K 8SM	150	234	206	1038.5	170.5	240	250	16	6	107
10SDS 55/3A 8SM	150	234	206	1038.5	170.5	240	250	16	6	107
10SDS 55/4S 8SM	150	234	206	1203.5	170.5	240	250	16	6	125
10SDS 55/4K 8SM	150	234	206	1203.5	170.5	240	250	16	6	125
10SDS 55/4A 8SM	150	234	206	1203.5	170.5	240	250	16	6	125
10SDS 55/5A 8SM	150	234	206	1368.5	170.5	240	250	16	6	143
10SDS 55/6A 8SM	150	234	206	1533.5	170.5	240	250	16	6	161
10SDS 55/7A 8SM	150	234	206	1698.5	170.5	240	250	16	6	179
10SDS 55/8A 8SM	150	234	206	1863.5	170.5	240	251	16	6	197
10SDS 55/9K 8SM	150	234	206	2028.5	170.5	240	251	16	6	216
10SDS 55/10A 8SM	150	234	206	2193.5	170.5	240	251	16	6	230
10SDS 55/11A 8SM	150	234	206	2358.5	170.5	240	251	16	6	248
10SDS 55/11A 12SM	150	234	206	2479	170.5	290	296	16	6	278
10SDS 55/12A 12SM	150	234	206	2644	170.5	290	296	16	6	296
10SDS 55/12A 8SM	150	234	206	2523.5	170.5	240	251	16	6	266
10SDS 55/13A 12SM	150	234	206	2809	170.5	290	296	16	6	314
10SDS 55/14A 12SM	150	234	206	2974	170.5	290	296	16	6	332
10SDS 55/15A 12SM	150	234	206	3139	170.5	290	296	16	6	350

### MOTORS TO CONNECT

STANDARD coupling flange:  
 (6SM) NEMA 6, 6" motor;  
 (8SM) NEMA 8, 8", 10" motor;  
 (12SM) C 12 Coupling, 12", 14" motor;

## Dimensions and weights

TYPE	DN2	mm								kg
		de	dk	f	j4	l4	l5	s	z	Weight
10SDS 64/1H 6SM	150	234	206	650	170.5	240	250	16	6	68.5
10SDS 64/1G 6SM	150	234	206	650	170.5	240	250	16	6	68.5
10SDS 64/1EF 6SM	150	234	206	650	170.5	240	250	16	6	68.5
10SDS 64/1CD 6SM	150	234	206	650	170.5	240	250	16	6	68.5
10SDS 64/1BC 6SM	150	234	206	650	170.5	240	250	16	6	68.5
10SDS 64/1A 6SM	150	234	206	650	170.5	240	250	16	6	68.5
10SDS 64/1A 8SM	150	234	206	675.5	170.5	240	250	16	6	66.5
10SDS 64/2EF 6SM	150	234	206	815	170.5	240	250	16	6	89
10SDS 64/2EF 8SM	150	234	206	840.5	170.5	240	250	16	6	87
10SDS 64/2CD 6SM	150	234	206	815	170.5	240	250	16	6	89
10SDS 64/2CD 8SM	150	234	206	840.5	170.5	240	250	16	6	87
10SDS 64/2BC 8SM	150	234	206	840.5	170.5	240	250	16	6	87
10SDS 64/2A 8SM	150	234	206	840.5	170.5	240	250	16	6	87
10SDS 64/3D 8SM	150	234	206	1005.5	170.5	240	250	16	6	107.5
10SDS 64/3C 8SM	150	234	206	1005.5	170.5	240	250	16	6	107.5
10SDS 64/3A 8SM	150	234	206	1005.5	170.5	240	250	16	6	107.5
10SDS 64/4B 8SM	150	234	206	1170.5	170.5	240	250	16	6	128
10SDS 64/4A 8SM	150	234	206	1170.5	170.5	240	250	16	6	128
10SDS 64/5BC 8SM	150	234	206	1335.5	170.5	240	250	16	6	148.5
10SDS 64/5K 8SM	150	234	206	1335.5	170.5	240	250	16	6	132

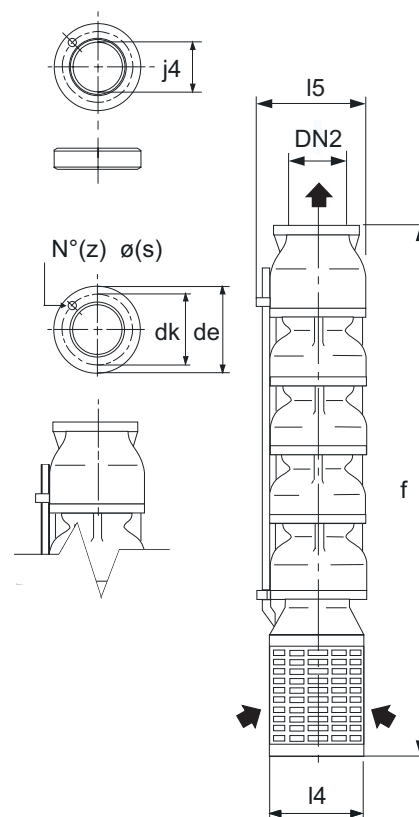

### MOTORS TO CONNECT

STANDARD coupling flange:

(6SM) NEMA 6, 6" motor;

(8SM) NEMA 8, 8", 10" motor;

(12SM) C 12 Coupling, 12", 14" motor;

## Dimensions and weights

TYPE	DN2	mm			kg Weight
		f	l4	l5	
10SDR 30/5A 8SM	G4	958.5	215	244	98
10SDR 30/6A 8SM	G4	1030.5	215	244	108
10SDR 30/8M 8SM	G4	1174.5	215	244	127
10SDR 30/9K 8SM	G4	1246.5	215	244	137
10SDR 30/10A 8SM	G4	1318.5	215	244	147
10SDR 30/11A 8SM	G4	1390.5	215	244	157
10SDR 30/13M 8SM	G4	1534.5	215	244	177
10SDR 30/14A 8SM	G4	1606.5	215	244	187
10SDR 30/15A 8SM	G4	1678.5	215	244	197
10SDR B30/16A 8SM	G4	1838.5	215	244	217
10SDR B30/17A 8SM	G4	1910.5	215	244	227
10SDR B30/18A 8SM	G4	1982.5	215	244	237
10SDR B30/19A 8SM	G4	2054.5	215	251	247
10SDR B30/20A 8SM	G4	2126.5	215	251	257

TYPE	DN2	mm			kg Weight
		f	l4	l5	
10SDR 35/5A 8SM	G4	958.5	215	244	95
10SDR 35/6A 8SM	G4	1030.5	215	244	105
10SDR 35/7A 8SM	G4	1102.5	215	244	115
10SDR 35/8A 8SM	G4	1174.5	215	244	125
10SDR 35/9A 8SM	G4	1246.5	215	244	135
10SDR 35/10A 8SM	G4	1318.5	215	244	145
10SDR 35/11A 8SM	G4	1390.5	215	244	155
10SDR 35/12A 8SM	G4	1462.5	215	244	165
10SDR 35/13A 8SM	G4	1534.5	215	244	175
10SDR B35/14A 8SM	G4	1694.5	215	244	195
10SDR B35/15A 8SM	G4	1766.5	215	244	205
10SDR B35/16A 8SM	G4	1838.5	215	244	215
10SDR B35/17A 8SM	G4	1910.5	215	244	225
10SDR B35/18A 8SM	G4	1982.5	215	251	235
10SDR B35/19A 8SM	G4	2054.5	215	251	245
10SDR B35/20A 8SM	G4	2126.5	215	251	255
10SDR B35/21A 8SM	G4	2198.5	215	251	265

TYPE	DN2	mm			kg Weight
		f	l4	l5	
10SDR 40/4B 8SM	G4	958.5	215	244	91
10SDR 40/4A 8SM	G4	958.5	215	244	91
10SDR 40/5I 8SM	G4	1048.5	215	244	101
10SDR 40/6K 8SM	G4	1138.5	215	244	111
10SDR 40/7M 8SM	G4	1228.5	215	244	121
10SDR 40/8AB 8SM	G4	1318.5	215	244	131
10SDR 40/8A 8SM	G4	1318.5	215	244	131
10SDR 40/9A 8SM	G4	1408.5	215	244	141
10SDR 40/10A 8SM	G4	1498.5	215	244	151
10SDR 40/11A 8SM	G4	1588.5	215	244	161
10SDR 40/12A 8SM	G4	1678.5	215	244	171
10SDR B40/13A 8SM	G4	1856.5	215	251	189
10SDR B40/14A 8SM	G4	1946.5	215	251	199
10SDR B40/15A 8SM	G4	2036.5	215	251	209
10SDR B40/16A 8SM	G4	2126.5	215	251	219
10SDR B40/17A 8SM	G4	2216.5	215	251	229
10SDR B40/18A 8SM	G4	2306.5	215	251	239

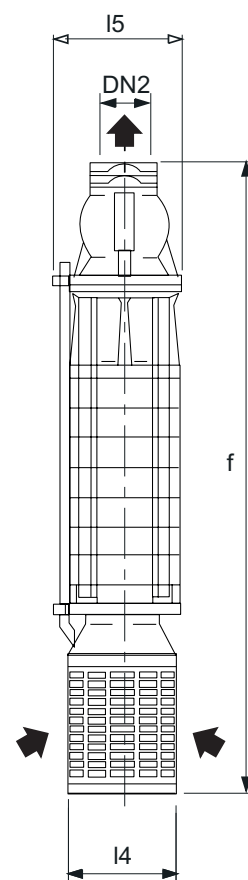

**MOTORS TO CONNECT**  
 STANDARD coupling flange:  
 (6SM) NEMA 6, 6" motor;  
 (8SM) NEMA 8, 8", 10" motor;  
 (12SM) C 12 Coupling, 12", 14" motor;

## Dimensions and weights

TYPE	DN2	mm								kg Weight
		de	dk	f	j4	l4	l5	s	z	
12SDS 42/4A 12SM	200	288	260	1420	221.5	290	298	18	8	243
12SDS 42/4A 8SM	150	234	206	1445.5	170.5	240	265	16	6	243
12SDS 42/5MN 12SM	200	288	260	1600	221.5	290	298	18	8	280
12SDS 42/5A 12SM	200	288	260	1600	221.5	290	298	18	8	280
12SDS 42/6P 12SM	200	288	260	1780	221.4	290	298	18	8	316.5
12SDS 42/6B 12SM	200	288	260	1780	221.5	290	298	18	8	316.5
12SDS 42/6A 12SM	200	288	260	1780	221.4	290	298	18	8	316.5
12SDS 42/7M 12SM	200	288	260	1960	221.5	290	298	18	8	353
12SDS 42/7A 12SM	200	288	260	1960	221.5	290	298	18	8	353
12SDS 42/8Q 12SM	200	288	260	2140	221.5	290	298	18	8	390
12SDS 42/8A 12SM	200	288	260	2140	221.5	290	298	18	8	390
12SDS 42/9M 12SM	200	288	260	2320	221.5	290	298	18	8	426

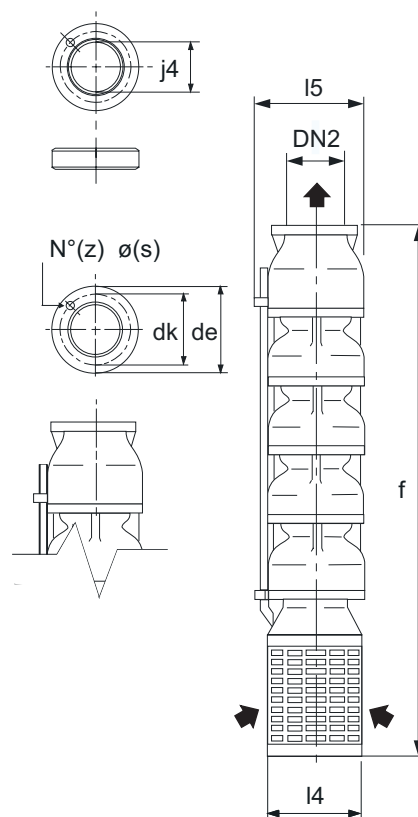

TYPE	DN2	mm								kg Weight
		de	dk	f	j4	l4	l5	s	z	
12SDS 50/1D 6SM	150	234	206	657	170.5	240	264	16	6	68.5
12SDS 50/1B 6SM	150	234	206	657	170.5	240	264	16	6	68.5
12SDS 50/1A 6SM	150	234	206	657	170.5	240	264	16	6	68.5
12SDS 50/2EF 6SM	150	234	206	832	170.5	240	264	16	6	89.5
12SDS 50/2DE 6SM	150	234	206	832	170.5	240	264	16	6	89.5
12SDS 50/2DE 8SM	150	234	206	857.5	170.5	240	264	16	6	90.5
12SDS 50/2BC 6SM	150	234	206	832	170.5	240	264	16	6	89.5
12SDS 50/2BC 8SM	150	234	206	857.5	170.5	240	264	16	6	90.5
12SDS 50/2A 6SM	150	234	206	832	170.5	240	264	16	6	89.5
12SDS 50/2A 8SM	150	234	206	857.5	170.5	240	264	16	6	90.5
12SDS 50/3C 8SM	150	234	206	1032.5	170.5	240	264	16	6	111.5
12SDS 50/3K 8SM	150	234	206	1032.5	170.5	240	264	16	6	111.5
12SDS 50/3A 8SM	150	234	206	1032.5	170.5	240	264	16	6	111.5
12SDS 50/4Z 8SM	150	234	206	1207.5	170.5	240	264	16	6	132.5
12SDS 50/4A 8SM	150	234	206	1032.5	170.5	240	264	16	6	132.5
12SDS 50/5BC 8SM	150	234	206	1382.5	170.5	240	264	16	6	153.5
12SDS 50/5A 8SM	150	234	206	1382.5	170.5	240	264	16	6	153.5
12SDS 50/6A 8SM	150	234	206	1557.5	170.5	240	265	16	6	174.5
12SDS 50/7I 8SM	150	234	206	1732.5	170.5	240	265	16	6	195.5
12SDS 50/8M 8SM	150	234	206	1907.5	170.5	240	265	16	6	216.5
12SDS 50/8A 12SM	150	234	206	2031	170.5	290	305	16	6	238.5
12SDS 50/8A 8SM	150	234	206	1933	170.5	240	265	16	6	216.5
12SDS 50/9A 12SM	150	234	206	2206	170.5	290	305	16	6	259.5
12SDS 50/10A 12SM	150	234	206	2381	170.5	290	305	16	6	280.5
12SDS 50/11A 12SM	150	234	206	2556	170.5	290	305	16	6	301.5
12SDS 50/12A 12SM	150	234	206	2731	170.5	290	305	16	6	322.5

**MOTORS TO CONNECT**  
 STANDARD coupling flange:  
 (6SM) NEMA 6, 6" motor;  
 (8SM) NEMA 8, 8", 10" motor;  
 (12SM) C 12 Coupling, 12", 14" motor;

## Dimensions and weights

TYPE	DN2	mm								kg
		de	dk	f	j4	l4	l5	s	z	Weight
12SDS 55/1GH 6SM	150	234	206	657	170.5	240	264	16	6	68.5
12SDS 55/1EF 6SM	150	234	206	657	170.5	240	264	16	6	68.5
12SDS 55/1D 6SM	150	234	206	657	170.5	240	264	16	6	68.5
12SDS 55/1B 6SM	150	234	206	657	170.5	240	264	16	6	68.5
12SDS 55/1B 8SM	150	234	206	682.5	170.5	240	264	16	6	69.5
12SDS 55/2GH 6SM	150	234	206	832	170.5	240	264	16	6	89.5
12SDS 55/2GH 8SM	150	234	206	857.5	170.5	240	264	16	6	90.5
12SDS 55/2EF 6SM	150	234	206	832	170.5	240	264	16	6	89.5
12SDS 55/2EF 8SM	150	234	206	857.5	170.5	240	264	16	6	90.5
12SDS 55/2D 6SM	150	234	206	832	170.5	240	264	16	6	89.5
12SDS 55/2D 8SM	150	234	206	857.5	170.5	240	264	16	6	90.5
12SDS 55/2B 8SM	150	234	206	857.5	170.5	240	264	16	6	90.5
12SDS 55/2A 8SM	150	234	206	857.5	170.5	240	264	16	6	90.5
12SDS 55/3DE 8SM	150	234	206	1032.5	170.5	240	264	16	6	111.5
12SDS 55/3CJ 8SM	150	234	206	1032.5	170.5	240	264	16	6	111.5
12SDS 55/3A 8SM	150	234	206	1032.5	170.5	240	264	16	6	111.5
12SDS 55/4JF 8SM	150	234	206	1207.5	170.5	240	264	16	6	132.5
12SDS 55/4D 8SM	150	234	206	1207.5	170.5	240	264	16	6	132.5
12SDS 55/4B 8SM	150	234	206	1207.5	170.5	240	264	16	6	132.5
12SDS 55/5D 8SM	150	234	206	1382.5	170.5	240	264	16	6	148
12SDS 55/5T 8SM	150	234	206	1382.5	170.5	240	265	16	6	153
12SDS 55/6BC 8SM	150	234	206	1557.5	170.5	240	265	16	6	174
12SDS 55/6A 8SM	150	234	206	1557.5	170.5	240	265	16	6	174
12SDS 55/7K 12SM	150	234	206	1856	170.5	290	305	16	6	217.5
12SDS 55/8A 12SM	150	234	206	2031	170.5	290	305	16	6	238.5
12SDS 55/9Q 12SM	150	234	206	2206	170.5	290	340	16	6	259.5
12SDS 55/9B 12SM	150	234	206	2206	170.5	290	305	16	6	259.5
12SDS 55/10A 12SM	150	234	206	2381	170.5	290	340	16	6	280.5

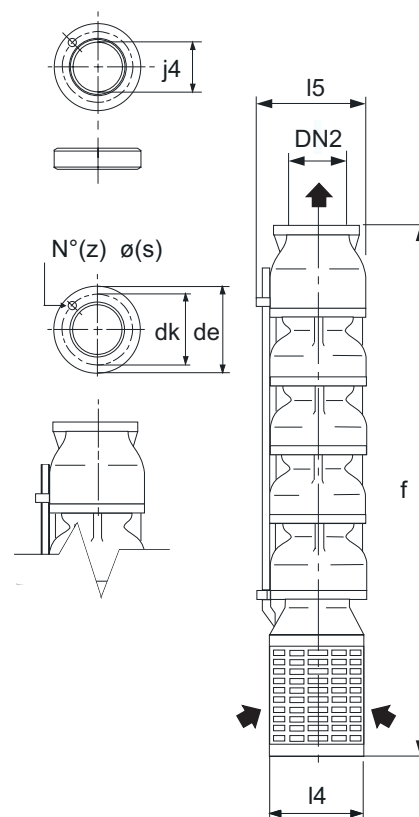

TYPE	DN2	mm								kg
		de	dk	f	j4	l4	l5	s	z	Weight
12SDS 58/1AB 6SM	150	234	206	685.5	170.5	240	264	16	6	68.5
12SDS 58/1AB 8SM	150	234	206	685.5	170.5	240	264	16	6	69.5
12SDS 58/2BC 8SM	150	234	206	860.5	170.5	240	264	16	6	90.5
12SDS 58/2AJ 8SM	150	234	206	860.5	170.5	240	264	16	6	90.5
12SDS 58/2A 8SM	150	234	206	860.5	170.5	240	264	16	6	90.5
12SDS 58/3W 8SM	150	234	206	1035.5	170.5	240	264	16	6	111.5
12SDS 58/3A 8SM	150	234	206	1035.5	170.5	240	264	16	6	111.5
12SDS 58/4M 8SM	150	234	206	1210.5	170.5	240	265	16	6	132.5
12SDS 58/4A 8SM	150	234	206	1210.5	170.5	240	265	16	6	132.5
12SDS 58/5M 12SM	150	234	206	1506	170.5	290	305	16	6	175.5
12SDS 58/5M 8SM	150	234	206	1385.5	170.5	240	265	16	6	153.5
12SDS 58/5I 8SM	150	234	206	1385.5	170.5	240	265	16	6	153.5
12SDS 58/5A 12SM	150	234	206	1506	170.5	290	305	16	6	175.5
12SDS 58/6Z 12SM	150	234	206	1681	170.5	290	305	16	6	196.5
12SDS 58/7Z 12SM	150	234	206	1856	170.5	290	305	16	6	217.5
12SDS 58/7X 12SM	150	234	206	1856	170.5	290	305	16	6	217.5
12SDS 58/7A 12SM	150	234	206	1856	170.5	290	305	16	6	217.5
12SDS 58/8AB 12SM	150	234	206	2031	170.5	290	305	16	6	238.5

### MOTORS TO CONNECT

STANDARD coupling flange:  
 (6SM) NEMA 6, 6" motor;  
 (8SM) NEMA 8, 8", 10" motor;  
 (12SM) C 12 Coupling, 12", 14" motor;

## Dimensions and weights

TYPE	DN2	mm								kg Weight
		de	dk	f	j4	l4	l5	s	z	
14SDS 50/1E 8SM	200	288	260	1110.5	221.5	290	342	18	8	167
14SDS 50/1D 8SM	200	288	260	1110.5	221.5	290	342	18	8	167
14SDS 50/1C 8SM	200	288	260	1110.5	221.5	290	342	18	8	167
14SDS 50/1B 8SM	200	288	260	1110.5	221.5	290	342	18	8	167
14SDS 50/1A 8SM	200	288	260	1110.5	221.5	290	342	18	8	167
14SDS 50/2E 8SM	200	288	260	1315.5	221.5	290	342	18	8	206.5
14SDS 50/2D 8SM	200	288	260	1315.5	221.5	290	342	18	8	206.5
14SDS 50/2CD 8SM	200	288	260	1315.5	221.5	290	342	18	8	206.5
14SDS 50/2BC 8SM	200	288	260	1315.5	221.5	290	342	18	8	206.5
14SDS 50/2AB 8SM	200	288	260	1315.5	221.5	290	342	18	8	206.5
14SDS 50/3C 8SM	200	288	260	1520.5	221.5	290	342	18	8	246
14SDS 50/3B 8SM	200	288	260	1520.5	221.5	290	342	18	8	246
14SDS 50/3A 8SM	200	288	260	1520.5	221.5	290	342	18	8	246
14SDS 50/3A 12SM	200	288	260	1495	221.5	290	342	18	8	260
14SDS 50/4BC 8SM	200	288	260	1725.5	221.5	290	342	18	8	299.5
14SDS 50/4BC 12SM	200	288	260	1700	221.5	290	342	18	8	299.5
14SDS 50/4I 12SM	200	288	260	1700	221.5	290	342	18	8	299.5
14SDS 50/5JC 12SM	200	288	260	1905	221.5	290	342	18	8	339
14SDS 50/5I 12SM	200	288	260	1905	221.5	290	342	18	8	339
14SDS 50/6W 12SM	200	288	260	2110	221.5	290	342	18	8	378.5
14SDS 50/6I 12SM	200	288	260	2110	221.5	290	342	18	8	378.5
14SDS 50/7Q 12SM	200	288	260	2315	221.5	290	342	18	8	418

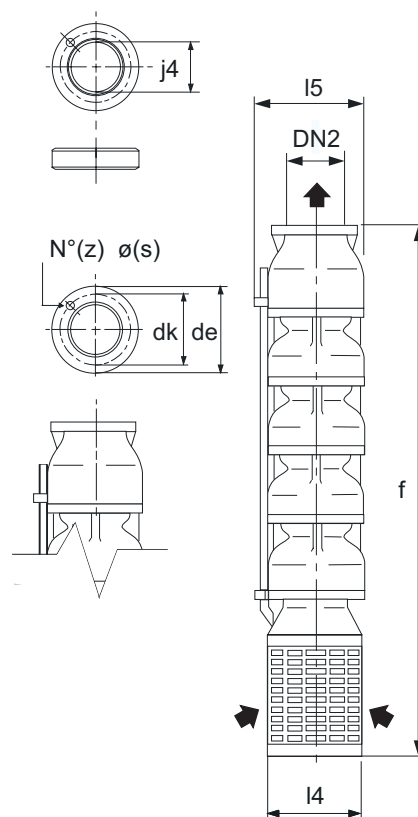

TYPE	DN2	mm								kg Weight
		de	dk	f	j4	l4	l5	s	z	
14SDS 55/1FG 8SM	230	326	293	1160.5	247	338	342	20	8	189
14SDS 55/1EF 8SM	230	326	293	1160.5	247	338	342	20	8	189
14SDS 55/1DE 8SM	230	326	293	1160.5	247	338	342	20	8	189
14SDS 55/1CJ 8SM	230	326	293	1160.5	247	338	342	20	8	189
14SDS 55/1C 8SM	230	326	293	1160.5	247	338	342	20	8	189
14SDS 55/1B 8SM	230	326	293	1160.5	247	338	342	20	8	189
14SDS 55/1A 8SM	230	326	293	1160.5	247	338	342	20	8	189
14SDS 55/2JF 8SM	230	326	293	1365.5	247	338	342	20	8	228
14SDS 55/2JE 8SM	230	326	293	1365.5	247	338	342	20	8	228
14SDS 55/2C 8SM	230	326	293	1365.5	247	338	342	20	8	228
14SDS 55/2JC 8SM	230	326	293	1365.5	247	338	342	20	8	228
14SDS 55/2AB 8SM	230	326	293	1365.5	247	338	342	20	8	228
14SDS 55/2AB 12SM	230	326	293	1340	247	338	342	20	8	242
14SDS 55/3D 8SM	230	326	293	1570.5	247	338	342	20	8	267
14SDS 55/3D 12SM	230	326	293	1545	247	338	342	20	8	281
14SDS 55/3JD 12SM	230	326	293	1545	247	338	342	20	8	281
14SDS 55/3BC 12SM	230	326	293	1545	247	338	342	20	8	281
14SDS 55/3B 12SM	230	326	293	1545	247	338	342	20	8	281
14SDS 55/3A 12SM	230	326	293	1545	247	338	342	20	8	281
14SDS E55/4BJ 12SM	230	326	293	1750	247	338	342	20	8	314
14SDS E55/4I 12SM	230	326	293	1750	247	338	342	20	8	314
14SDS E55/4B 12SM	230	326	293	1750	247	338	342	20	8	314
14SDS E55/5C 12SM	230	326	293	1955	247	338	342	20	8	354
14SDS E55/5BC 12SM	230	326	293	1955	247	338	342	20	8	354

### MOTORS TO CONNECT

STANDARD coupling flange:  
 (6SM) NEMA 6, 6" motor;  
 (8SM) NEMA 8, 8", 10" motor;  
 (12SM) C 12 Coupling, 12", 14" motor;

## Dimensions and weights

TYPE	DN2	mm								kg Weight
		de	dk	f	j4	l4	l5	s	z	
14SDS 64/1L 8SM	230	326	293	1017.5	247	338	352	20	8	180
14SDS 64/1H 8SM	230	326	293	1017.5	247	338	352	20	8	180
14SDS 64/1G 8SM	230	326	293	1017.5	247	338	352	20	8	180
14SDS 64/1F 8SM	230	326	293	1017.5	247	338	352	20	8	180
14SDS 64/1D 8SM	230	326	293	1017.5	247	338	352	20	8	180
14SDS 64/1B 8SM	230	326	293	1017.5	247	338	352	20	8	180
14SDS 64/1A 8SM	230	326	293	1017.5	247	338	352	20	8	180
14SDS 64/2G 8SM	230	326	293	1232.5	247	338	352	20	8	232
14SDS 64/2EF 8SM	230	326	293	1232.5	247	338	352	20	8	232
14SDS 64/2DE 8SM	230	326	293	1232.5	247	338	352	20	8	232
14SDS 64/2DE 12SM	230	326	293	1180	247	338	352	20	8	245
14SDS 64/2C 12SM	230	326	293	1180	247	338	352	20	8	245
14SDS 64/2A 12SM	230	326	293	1180	247	338	352	20	8	245
14SDS 64/3JF 12SM	230	326	293	1395	247	338	352	20	8	297
14SDS 64/3JD 12SM	230	326	293	1395	247	338	352	20	8	297
14SDS 64/3B 12SM	230	326	293	1395	247	338	352	20	8	297
14SDS 64/3A 12SM	230	326	293	1395	247	338	352	20	8	297
14SDS 64/4CD 12SM	230	326	293	1610	247	338	352	20	8	349

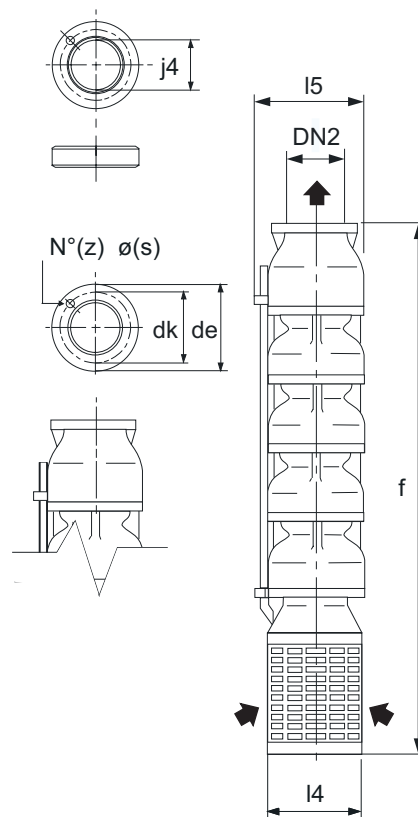

TYPE	DN2	mm								kg Weight
		de	dk	f	j4	l4	l5	s	z	
18SDS 64/1L 8SM	230	326	293	1200.5	247	384	435	20	8	260
18SDS 64/1H 8SM	230	326	293	1200.5	247	384	435	20	8	260
18SDS 64/1G 8SM	230	326	293	1200.5	247	384	435	20	8	260
18SDS 64/1F 8SM	230	326	293	1200.5	247	384	435	20	8	260
18SDS 64/1D 8SM	230	326	293	1200.5	247	384	445	20	8	260
18SDS 64/1B 8SM	230	326	293	1200.5	247	384	435	20	8	260
18SDS 64/1A 8SM	230	326	293	1200.5	247	384	435	20	8	241
18SDS 64/2G 8SM	230	326	293	1470.5	247	384	435	20	8	336
18SDS 64/2EF 8SM	230	326	293	1470.5	247	384	435	20	8	336
18SDS 64/2DE 8SM	230	326	293	1470.5	247	384	435	20	8	336
18SDS 64/2DE 12SM	230	326	293	1445	247	384	435	20	8	353
18SDS 64/2C 12SM	230	326	293	1445	247	384	435	20	8	353
18SDS 64/2A 12SM	230	326	293	1445	247	384	435	20	8	353
18SDS 64/3JF 12SM	230	326	293	1715	247	384	435	20	8	429
18SDS 64/3B 12SM	230	326	293	1715	247	384	435	20	8	429
18SDS 64/3A 12SM	230	326	293	1715	247	384	435	20	8	429
18SDS 64/4CD 12SM	230	326	293	1985	247	384	435	20	8	505

### MOTORS TO CONNECT

STANDARD coupling flange:  
 (6SM) NEMA 6, 6" motor;  
 (8SM) NEMA 8, 8", 10" motor;  
 (12SM) C 12 Coupling, 12", 14" motor;

## Dimensions and weights

TYPE	DN2	f	mm		kg
			l4	l5	Weight
I-6SDR 30/9A 6SM	G2 1/2	747	141	148	26.8
I-6SDR 30/13A 6SM	G2 1/2	927	141	148	34.1
I-6SDR 30/18A 6SM	G2 1/2	1152	141	148	43.3
I-6SDR 30/22A 6SM	G2 1/2	1332	141	148	50.7
I-6SDR 30/26A 6SM	G2 1/2	1512	141	148	58
I-6SDR 30/31A 6SM	G2 1/2	1737	141	148	67.2
I-6SDR 30/36A 6SM	G2 1/2	1962	141	148	76.4
I-6SDR 30/40A 6SM	G2 1/2	2142	141	148	83.8
I-6SDR 30/45A 6SM	G2 1/2	2367	141	148	93
I-6SDR 30/49A 6SM	G2 1/2	2547	141	148	100.4
I-6SDR 30/53A 6SM	G2 1/2	2727	141	148	107.7
I-6SDR 30/56A 6SM	G2 1/2	2862	141	148	113.2
I-6SDR 30/60A 6SM	G2 1/2	3042	141	148	120.6

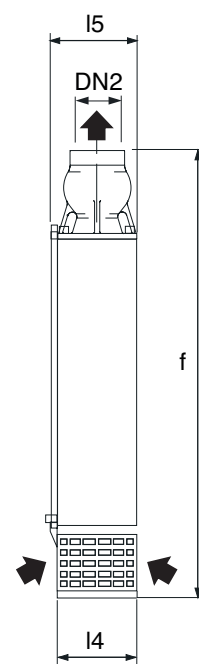

TYPE	DN2	f	mm		kg
			l4	l5	Weight
I-6SDR 37/7A 6SM	G2 1/2	657	141	148	22.5
I-6SDR 37/9A 6SM	G2 1/2	747	141	148	26.1
I-6SDR 37/11A 6SM	G2 1/2	837	141	148	29.6
I-6SDR 37/13A 6SM	G2 1/2	927	141	148	33.2
I-6SDR 37/16A 6SM	G2 1/2	1062	141	148	38.5
I-6SDR 37/19A 6SM	G2 1/2	1197	141	148	43.8
I-6SDR 37/22A 6SM	G2 1/2	1332	141	148	49.1
I-6SDR 37/26A 6SM	G2 1/2	1512	141	148	56.2
I-6SDR 37/29A 6SM	G2 1/2	1647	141	148	61.5
I-6SDR 37/32A 6SM	G2 1/2	1782	141	148	66.8
I-6SDR 37/35A 6SM	G2 1/2	1917	141	148	72.1
I-6SDR 37/38A 6SM	G2 1/2	2052	141	148	77.4
I-6SDR 37/41A 6SM	G2 1/2	2187	141	148	82.7
I-6SDR 37/45A 6SM	G2 1/2	2367	141	148	89.8
I-6SDR 37/48A 6SM	G2 1/2	2502	141	148	95.1
I-6SDR 37/52A 6SM	G2 1/2	2682	141	148	102.2
I-6SDR 37/56A 6SM	G2 1/2	2862	141	148	109.3
I-6SDR 37/60A 6SM	G2 1/2	3042	141	148	116.4

**MOTORS TO CONNECT**  
STANDARD coupling flange:  
(6SM) NEMA 6, 6" motor

TYPE	DN2	f	mm		kg
			l4	l5	Weight
I-6SDR 47/4I 6SM	G3	587	141	148	17.3
I-6SDR 47/5A 6SM	G3	644	141	148	19.5
I-6SDR 47/7A 6SM	G3	758	141	148	23.9
I-6SDR 47/9I 6SM	G3	872	141	148	28.3
I-6SDR 47/10A 6SM	G3	929	141	148	30.5
I-6SDR 47/12A 6SM	G3	1043	141	148	34.9
I-6SDR 47/14A 6SM	G3	1157	141	148	39.3
I-6SDR 47/17A 6SM	G3	1328	141	148	45.9
I-6SDR 47/21A 6SM	G3	1556	141	148	54.7
I-6SDR 47/25A 6SM	G3	1784	141	148	63.5
I-6SDR 47/28A 6SM	G3	1955	141	148	70.1
I-6SDR 47/31A 6SM	G3	2126	141	148	76.7
I-6SDR 47/35A 6SM	G3	2354	141	148	85.5

## Dimensions and weights

TYPE	DN2	mm			kg Weight
		f	l4	l5	
I-6SDS 50/3A 6SM	G3	727	141	150	25.5
I-6SDS 50/4A 6SM	G3	842	141	150	30
I-6SDS 50/6M 6SM	G3	1072	141	150	44
I-6SDS 50/7I 6SM	G3	1187	141	150	48.5
I-6SDS 50/8A 6SM	G3	1302	141	150	54
I-6SDS 50/9A 6SM	G3	1417	141	150	58.5
I-6SDS 50/11A 6SM	G3	1647	141	150	69
I-6SDS 50/14A 6SM	G3	1992	141	150	81
I-6SDS 50/16A 6SM	G3	2222	141	150	90
I-6SDS 50/19A 6SM	G3	2567	141	150	107
I-6SDS 50/22A 6SM	G3	2912	141	150	124
I-6SDS 50/28A 6SM	G3	3602	141	150	152.5

TYPE	DN2	mm			kg Weight
		f	l4	l5	
I-6SDS 55/2I 6SM	G3	612	141	150	21
I-6SDS 55/3P 6SM	G3	727	141	150	28.5
I-6SDS 55/4P 6SM	G3	842	141	150	33
I-6SDS 55/5Q 6SM	G3	957	141	150	37.5
I-6SDS 55/6Z 6SM	G3	1072	141	150	40
I-6SDS 55/7Z 6SM	G3	1187	141	150	35.5
I-6SDS 55/8S 6SM	G3	1302	141	150	52
I-6SDS 55/9A 6SM	G3	1417	141	150	56.5
I-6SDS 55/11M 6SM	G3	1647	141	150	65
I-6SDS 55/13M 6SM	G3	1877	141	150	74
I-6SDS 55/15M 6SM	G3	2107	141	150	84
I-6SDS 55/18A 6SM	G3	2452	141	150	101.5
I-6SDS 55/21A 6SM	G3	2797	141	150	124

TYPE	DN2	mm			kg Weight
		f	l4	l5	
I-6SDS 64/2I 6SM	G4	612	141	150	26
I-6SDS 64/3K 6SM	G4	727	141	150	29.5
I-6SDS 64/4K 6SM	G4	842	141	150	35
I-6SDS 64/5M 6SM	G4	957	141	150	35.5
I-6SDS 64/6M 6SM	G4	1072	141	150	38
I-6SDS 64/7MN 6SM	G4	1187	141	150	44
I-6SDS 64/7A 6SM	G4	1187	141	150	49
I-6SDS 64/9A 6SM	G4	1417	141	150	73.3
I-6SDS 64/11K 6SM	G4	1647	141	150	62
I-6SDS 64/13K 6SM	G4	1877	141	150	76
I-6SDS 64/15K 6SM	G4	2107	141	150	117
I-6SDS 64/18A 6SM	G4	2452	141	150	92
I-6SDS 64/21A 6SM	G4	2797	141	150	124

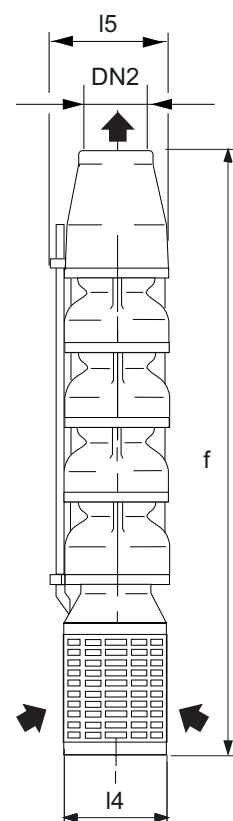

### MOTORS TO CONNECT

STANDARD coupling flange:  
 (6SM) NEMA 6, 6" motor;  
 (8SM) NEMA 8, 8", 10" motor;  
 (12SM) C 12 Coupling, 12", 14" motor;

## Dimensions and weights

TYPE	DN2	f	mm		kg Weight
			l4	l5	
I-8SDS 65/1D 6SM	G5	560	192	203	24.4
I-8SDS 65/1A 6SM	G5	560	192	203	24.4
I-8SDS 65/2T 6SM	G5	695	192	203	32.5
I-8SDS 65/2C 6SM	G5	695	192	203	32.5
I-8SDS 65/2A 6SM	G5	695	192	203	32.5
I-8SDS 65/3E 6SM	G5	830	192	203	40.7
I-8SDS 65/3JD 6SM	G5	830	192	203	40.7
I-8SDS 65/3K 6SM	G5	830	192	203	40.7
I-8SDS 65/4JC 6SM	G5	965	192	203	48.8
I-8SDS 65/4A 6SM	G5	965	192	203	48.8
I-8SDS 65/5KC 6SM	G5	1100	192	203	57
I-8SDS 65/5A 6SM	G5	1100	192	203	57
I-8SDS 65/6U 6SM	G5	1235	192	203	65.1
I-8SDS 65/6U 8SM	G5	1260.5	192	203	65.1
I-8SDS 65/6C 6SM	G5	1235	192	203	65.1
I-8SDS 65/6C 8SM	G5	1260.5	192	203	65.1
I-8SDS 65/7A 6SM	G5	1370	192	203	73.3
I-8SDS 65/7A 8SM	G5	1395.5	192	203	73.3
I-8SDS 65/9T 6SM	G5	1640	192	203	89.6
I-8SDS 65/9T 8SM	G5	1665.5	192	203	89.6
I-8SDS 65/10Z 8SM	G5	1800.5	192	203	97.7
I-8SDS 65/11A 8SM	G5	1935.5	192	203	105.9
I-8SDS 65/12A 8SM	G5	2070.5	192	203	114
I-8SDS 65/14A 8SM	G5	2340.5	192	203	130.3
I-8SDS 65/16A 8SM	G5	2610.5	192	203	146.6
I-8SDS 65/17A 8SM	G5	2745.5	192	203	154.8

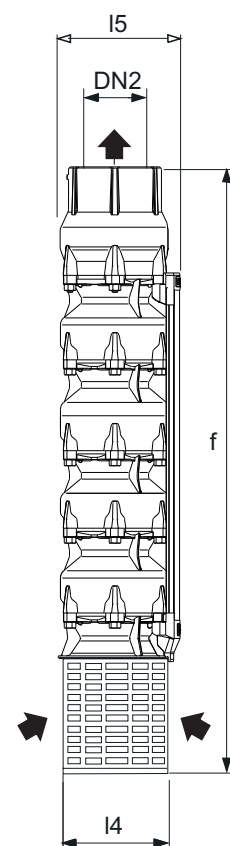

TYPE	DN2	f	mm		kg Weight
			l4	l5	
I-8SDS 95/1C 6SM	G5	565	192	203	25.8
I-8SDS 95/1A 6SM	G5	565	192	203	25.8
I-8SDS 95/2F 6SM	G5	705	192	203	34
I-8SDS 95/2DF 6SM	G5	705	192	203	34
I-8SDS 95/2D 6SM	G5	705	192	203	34
I-8SDS 95/2C 6SM	G5	705	192	203	34
I-8SDS 95/2A 6SM	G5	705	192	203	34
I-8SDS 95/3DJ 6SM	G5	845	192	203	42.2
I-8SDS 95/3C 6SM	G5	845	192	203	42.2
I-8SDS 95/3A 6SM	G5	845	192	203	42.2
I-8SDS 95/4D 6SM	G5	985	192	203	50.4
I-8SDS 95/4C 6SM	G5	985	192	203	50.4
I-8SDS 95/4C 8SM	G5	1010.5	192	203	50.4
I-8SDS 95/4A 6SM	G5	985	192	203	50.4
I-8SDS 95/4A 8SM	G5	1010.5	192	203	50.4
I-8SDS 95/5KC 6SM	G5	1125	192	203	58.6
I-8SDS 95/5KC 8SM	G5	1150.5	192	203	58.6
I-8SDS 95/5A 6SM	G5	1125	192	203	58.6
I-8SDS 95/5A 8SM	G5	1150.5	192	203	58.6
I-8SDS 95/6QC 6SM	G5	1125	192	203	66.8
I-8SDS 95/6QC 8SM	G5	1290.5	192	203	66.8
I-8SDS 95/7ZC 8SM	G5	1430.5	192	203	75
I-8SDS 95/7Z 8SM	G5	1430.5	192	203	75
I-8SDS 95/8Z 8SM	G5	1570.5	192	203	83.2
I-8SDS 95/10XC 8SM	G5	1850.5	192	203	99.6
I-8SDS 95/10A 8SM	G5	1850.5	192	203	99.6
I-8SDS 95/12C 8SM	G5	2130.5	192	203	116

### MOTORS TO CONNECT

STANDARD coupling flange:

(6SM) NEMA 6, 6" motor;

(8SM) NEMA 8, 8", 10" motor;

(12SM) C 12 Coupling, 12", 14" motor;

## Dimensions and weights

TYPE	DN2	mm			kg Weight
		f	l4	l5	
I-8SDS 135/1F 6SM	G5	565	192	203	24.8
I-8SDS 135/1D 6SM	G5	565	192	203	24.8
I-8SDS 135/1B 6SM	G5	565	192	203	24.8
I-8SDS 135/2G 6SM	G5	705	192	203	32.5
I-8SDS 135/2F 6SM	G5	705	192	203	32.5
I-8SDS 135/2E 6SM	G5	705	192	203	32.5
I-8SDS 135/2D 6SM	G5	705	192	203	32.5
I-8SDS 135/2B 6SM	G5	705	192	203	32.5
I-8SDS 135/3E 6SM	G5	845	192	203	40.2
I-8SDS 135/3D 6SM	G5	845	192	203	40.2
I-8SDS 135/3B 6SM	G5	845	192	203	40.2
I-8SDS 135/4D 6SM	G5	985	192	203	47.9
I-8SDS 135/4D 8SM	G5	1010.5	192	203	47.9
I-8SDS 135/4C 6SM	G5	985	192	203	47.9
I-8SDS 135/4C 8SM	G5	1010.5	192	203	47.9
I-8SDS 135/5D 6SM	G5	1125	192	203	55.6
I-8SDS 135/5D 8SM	G5	1150.5	192	203	55.6
I-8SDS 135/5B 6SM	G5	1125	192	203	55.6
I-8SDS 135/5B 8SM	G5	1150.5	192	203	55.6
I-8SDS 135/6C 8SM	G5	1290.5	192	203	63.3
I-8SDS 135/7C 8SM	G5	1430.5	192	203	71
I-8SDS 135/7A 8SM	G5	1430.5	192	203	71
I-8SDS 135/8C 8SM	G5	1570.5	192	203	78.7
I-8SDS 135/8A 8SM	G5	1570.5	192	203	78.7
I-8SDS 135/9C 8SM	G5	1710.5	192	203	86.4
I-8SDS 135/10C 8SM	G5	1850.5	192	203	94.1
I-8SDS 135/11C 8SM	G5	1990.5	192	203	101.8

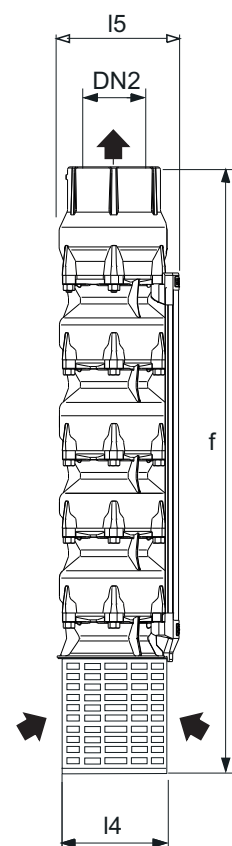

TYPE	DN2	mm			kg Weight
		f	l4	l5	
I-10SDS 200/1F 6SM	G6	714	235	250.5	63
I-10SDS 200/1E 6SM	G6	714	235	250.5	63
I-10SDS 200/1DE 6SM	G6	714	235	250.5	63.5
I-10SDS 200/1D 6SM	G6	714	235	250.5	63.5
I-10SDS 200/1C 6SM	G6	714	235	250.5	63.5
I-10SDS 200/1B 6SM	G6	714	235	250.5	64
I-10SDS 200/2E 6SM	G6	889	235	250.5	79
I-10SDS 200/2DE 6SM	G6	889	235	250.5	79
I-10SDS 200/2DE 8SM	G6	914.5	235	251	79
I-10SDS 200/2CD 6SM	G6	889	235	250.5	79.5
I-10SDS 200/2CD 8SM	G6	914.5	235	251	79.5
I-10SDS 200/2BC 6SM	G6	889	235	250.5	80
I-10SDS 200/2BC 8SM	G6	914.5	235	251	80
I-10SDS 200/2AB 8SM	G6	914.5	235	251	80.5
I-10SDS 200/3D 8SM	G6	1089.5	235	251	95
I-10SDS 200/3CD 8SM	G6	1089.5	235	251	95.5
I-10SDS 200/3BC 8SM	G6	1089.5	235	251	96.5
I-10SDS 200/3AB 8SM	G6	1089.5	235	251	97
I-10SDS 200/4D 8SM	G6	1264.5	235	251	111.5
I-10SDS 200/4BC 8SM	G6	1264.5	235	251	112.5
I-10SDS 200/4A 8SM	G6	1264.5	235	251	114
I-10SDS 200/5CD 8SM	G6	1439.5	235	251	128
I-10SDS 200/5AB 8SM	G6	1439.5	235	254	130
I-10SDS 200/6CD 8SM	G6	1614.5	235	251	144
I-10SDS 200/6BC 8SM	G6	1614.5	235	254	145
I-10SDS 200/6B 8SM	G6	1614.5	235	254	144.5
I-10SDS 200/7C 8SM	G6	1789.5	235	254	160
I-10SDS 200/7AB 8SM	G6	1789.5	235	259	163
I-10SDS 200/8C 8SM	G6	1964.5	235	259	176
I-10SDS 200/8C 12SM	G6	2085	235	290	190.5
I-10SDS 200/8B 8SM	G6	1964.5	235	259	176.5
I-10SDS 200/8A 12SM	G6	2085	235	290	193.5
I-10SDS 200/9C 12SM	G6	2260	235	290	206.5
I-10SDS 200/9A 12SM	G6	2260	235	290	210
I-10SDS 200/10A 12SM	G6	2435	235	340	227
I-10SDS 200/11B 12SM	G6	2610	235	340	243.5
I-10SDS 200/11A 12SM	G6	2610	235	290	243.5
I-10SDS 200/12JD 12SM	G6	2785	235	340	254.5
I-10SDS 200/13D 12SM	G6	2960	235	290	269
I-10SDS 200/14D 12SM	G6	3135	235	290	285

### MOTORS TO CONNECT

STANDARD coupling flange:

(6SM) NEMA 6, 6" motor;

(8SM) NEMA 8, 8", 10" motor;

(12SM) C 12 Coupling, 12", 14" motor;

## Dimensions and weights

TYPE	DN2	mm			kg Weight
		f	l4	l5	
I-10SDS 250/1I 6SM	G6	714	235	250,5	62
I-10SDS 250/1H 6SM	G6	714	235	250,5	62
I-10SDS 250/1F 6SM	G6	714	235	250,5	62.5
I-10SDS 250/1DE 6SM	G6	714	235	250,5	62.5
I-10SDS 250/1C 6SM	G6	714	235	250,5	63
I-10SDS 250/1A 6SM	G6	714	235	250,5	63
I-10SDS 250/1A 8SM	G6	739.5	235	251	63
I-10SDS 250/2HI 6SM	G6	889	235	250,5	77.5
I-10SDS 250/2H 6SM	G6	889	235	250,5	77.5
I-10SDS 250/2H 8SM	G6	914.5	235	251	77.5
I-10SDS 250/2F 6SM	G6	889	235	250,5	79
I-10SDS 250/2F 8SM	G6	914.5	235	251	79
I-10SDS 250/2G 6SM	G6	889	235	250,5	77.5
I-10SDS 250/2G 8SM	G6	914.5	235	251	77.5
I-10SDS 250/2DE 6SM	G6	889	235	250,5	79.5
I-10SDS 250/2DE 8SM	G6	914.5	235	251	79.5
I-10SDS 250/2C 8SM	G6	914.5	235	251	79.7
I-10SDS 250/2A 8SM	G6	914.5	235	251	80
I-10SDS 250/3EF 8SM	G6	1089.5	235	251	95.5
I-10SDS 250/3JE 8SM	G6	1089.5	235	251	96
I-10SDS 250/3C 8SM	G6	1089.5	235	251	96.5
I-10SDS 250/3A 8SM	G6	1089.5	235	251	97
I-10SDS 250/4EF 8SM	G6	1264.5	235	251	112
I-10SDS 250/4D 8SM	G6	1264.5	235	251	113
I-10SDS 250/4M 8SM	G6	1264.5	235	251	114
I-10SDS 250/5JE 8SM	G6	1439.5	235	251	127
I-10SDS 250/5BC 8SM	G6	1439.5	235	254	161.5
I-10SDS 250/5A 8SM	G6	1439.5	235	254	131
I-10SDS 250/6QC 8SM	G6	1614.5	235	254	148
I-10SDS 250/6S 8SM	G6	1614.5	235	259	148
I-10SDS 250/6MN 12SM	G6	1735	235	290	161
I-10SDS 250/6A 8SM	G6	1614.5	235	259	148
I-10SDS 250/7V 12SM	G6	1910	235	290	178
I-10SDS 250/8B 12SM	G6	2085	235	290	195
I-10SDS 250/8N 12SM	G6	2085	235	340	195
I-10SDS 250/9B 12SM	G6	2260	235	290	212
I-10SDS 250/10B 12SM	G6	2435	235	340	229
I-10SDS 250/10A 12SM	G6	2435	235	290	229

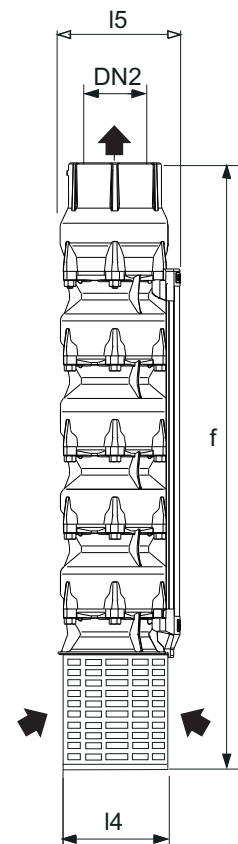

### MOTORS TO CONNECT

STANDARD coupling flange:

(6SM) NEMA 6, 6" motor;

(8SM) NEMA 8, 8", 10" motor;

(12SM) C 12 Coupling, 12", 14" motor;

TYPE	DN2	mm			kg Weight
		f	l4	l5	
I-10SDS 315/1CD 6SM	G6	714	235	250,5	63
I-10SDS 315/1BC 6SM	G6	714	235	250,5	63
I-10SDS 315/1BC 8SM	G6	739.5	235	251	63
I-10SDS 315/1AB 6SM	G6	714	235	250,5	63
I-10SDS 315/1AB 8SM	G6	739.5	235	251	63
I-10SDS 315/2DE 6SM	G6	889	235	250,5	62.5
I-10SDS 315/2DE 8SM	G6	914.5	235	251	79
I-10SDS 315/2CD 8SM	G6	914.5	235	251	79.5
I-10SDS 315/2BC 8SM	G6	914.5	235	251	79.5
I-10SDS 315/2B 8SM	G6	914.5	235	251	80
I-10SDS 315/2A 8SM	G6	914.5	235	251	80
I-10SDS 315/3W 8SM	G6	1089.5	235	251	96
I-10SDS 315/3A 8SM	G6	1089.5	235	251	95
I-10SDS 315/4B 8SM	G6	1264.5	235	254	114
I-10SDS 315/4A 8SM	G6	1264.5	235	254	110
I-10SDS 315/5B 8SM	G6	1439.5	235	259	131
I-10SDS 315/5M 12SM	G6	1560	235	290	143.5
I-10SDS 315/5I 8SM	G6	1439.5	235	259	131
I-10SDS 315/5A 12SM	G6	1560	235	290	143.5
I-10SDS 315/6I 12SM	G6	1910	235	290	177.5
I-10SDS 315/7X 12SM	G6	1910	235	290	177.5
I-10SDS 315/7A 12SM	G6	1735	235	340	177.5
I-10SDS 315/8A 12SM	G6	2085	235	290	194.5

## Dimensions and weights

TYPE	DN2	mm								kg Weight
		de	dk	f	j4	l4	l5	s	z	
I-12SDS 430/1D 8SM	221	290	264	974.5	221	290	303	15	9	116.4
I-12SDS 430/1CJ 8SM	221	290	264	974.5	221	290	303	15	9	116.4
I-12SDS 430/1CD 8SM	221	290	264	974.5	221	290	303	15	9	116.4
I-12SDS 430/1C 8SM	221	290	264	974.5	221	290	303	15	9	116.4
I-12SDS 430/1BC 8SM	221	290	264	974.5	221	290	303	15	9	116.4
I-12SDS 430/1B 8SM	221	290	264	974.5	221	290	303	15	9	116.4
I-12SDS 430/1A 8SM	221	290	264	974.5	221	290	303	15	9	116.4
I-12SDS 430/2E 8SM	221	290	264	1189.5	221	290	303	15	9	153.4
I-12SDS 430/2DE 8SM	221	290	264	1189.5	221	290	303	15	9	153.4
I-12SDS 430/2D 8SM	221	290	264	1189.5	221	290	303	15	9	153.4
I-12SDS 430/2CD 8SM	221	290	264	1189.5	221	290	303	15	9	153.4
I-12SDS 430/2C 8SM	221	290	264	1189.5	221	290	303	15	9	153.4
I-12SDS 430/2B 8SM	221	290	264	1189.5	221	290	303	15	9	153.4
I-12SDS 430/2AB 8SM	221	290	264	1189.5	221	290	303	15	9	153.4
I-12SDS 430/2A 12SM	221	290	264	1170	221	290	320,5	15	9	158.9
I-12SDS 430/2A 8SM	221	290	264	1189.5	221	290	303	15	9	153.4
I-12SDS 430/3CJ 8SM	221	290	264	1404.5	221	290	303	15	9	190.3
I-12SDS 430/3JD 8SM	221	290	264	1404.5	221	290	303	15	9	190.3
I-12SDS 430/3C 12SM	221	290	264	1385	221	290	320,5	15	9	195.8
I-12SDS 430/3Q 8SM	221	290	264	1404.5	221	290	303	15	9	190.3
I-12SDS 430/3W 12SM	221	290	264	1385	221	290	320,5	15	9	195.8
I-12SDS 430/3AB 12SM	221	290	264	1385	221	290	320,5	15	9	195.8
I-12SDS 430/3A 12SM	221	290	264	1385	221	290	320,5	15	9	195.8
I-12SDS E430/4D 12SM	221	290	264	1600	221	290	320,5	15	9	232.8
I-12SDS E430/4CD 8SM	221	290	264	1619.5	221	290	303	15	9	227.3
I-12SDS E430/4CD 12SM	221	290	264	1600	221	290	320,5	15	9	232.8
I-12SDS E430/4C 12SM	221	290	264	1600	221	290	320,5	15	9	232.8
I-12SDS E430/4M 12SM	221	290	264	1600	221	290	320,5	15	9	232.8
I-12SDS E430/4I 12SM	221	290	264	1600	221	290	320,5	15	9	232.8
I-12SDS E430/4A 12SM	221	290	264	1600	221	290	320,5	15	9	232.8
I-12SDS E430/5JD 12SM	221	290	264	1815	221	290	320,5	15	9	269.8
I-12SDS E430/5C 12SM	221	290	264	1815	221	290	320,5	15	9	269.8
I-12SDS E430/5BC 12SM	221	290	264	1815	221	290	320,5	15	9	269.8
I-12SDS E430/5B 12SM	221	290	264	1815	221	290	320,5	15	9	269.8
I-12SDS E430/5MN 12SM	221	290	264	1815	221	290	320,5	15	9	269.8
I-12SDS E430/5K 12SM	221	290	264	1815	221	290	320,5	15	9	269.8
I-12SDS E430/5A 12SM	221	290	264	1815	221	290	320,5	15	9	269.8
I-12SDS E430/6BJ 12SM	221	290	264	2030	221	290	320,5	15	9	306.7
I-12SDS E430/7D 12SM	221	290	264	2245	221	290	320,5	15	9	343.7
I-12SDS E430/7QC 12SM	221	290	264	2245	221	290	320,5	15	9	343.7
I-12SDS E430/7C 12SM	221	290	264	2245	221	290	320,5	15	9	343.7
I-12SDS E430/8D 12SM	221	290	264	2460	221	290	320,5	15	9	380.7
I-12SDS E430/9D 12SM	221	290	264	2675	221	290	320,5	15	9	417.7
I-12SDS E430/11D 12SM	221	290	264	3105	221	290	320,5	15	9	491.6

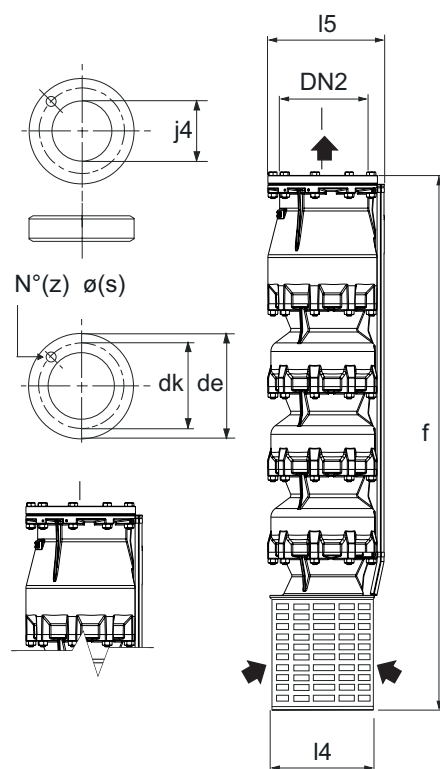

**MOTORS TO CONNECT**  
 STANDARD coupling flange:  
 (6SM) NEMA 6, 6" motor;  
 (8SM) NEMA 8, 8", 10" motor;  
 (12SM) C 12 Coupling, 12", 14" motor;

## Cables connection kit

It allows connection of electric cables with junction submerged in water.

The kit includes:

- 4 connectors
- 4 shrink-sheaths for protection of individual wires
- 1 shrink-sheath for protection of the 4-pole wire.

The shrinkage of the sheath occurs with the action of a heat source (flame or hair dryer) that causes the resin to escape, thus guaranteeing the watertightness of the joint.



## Plant examples

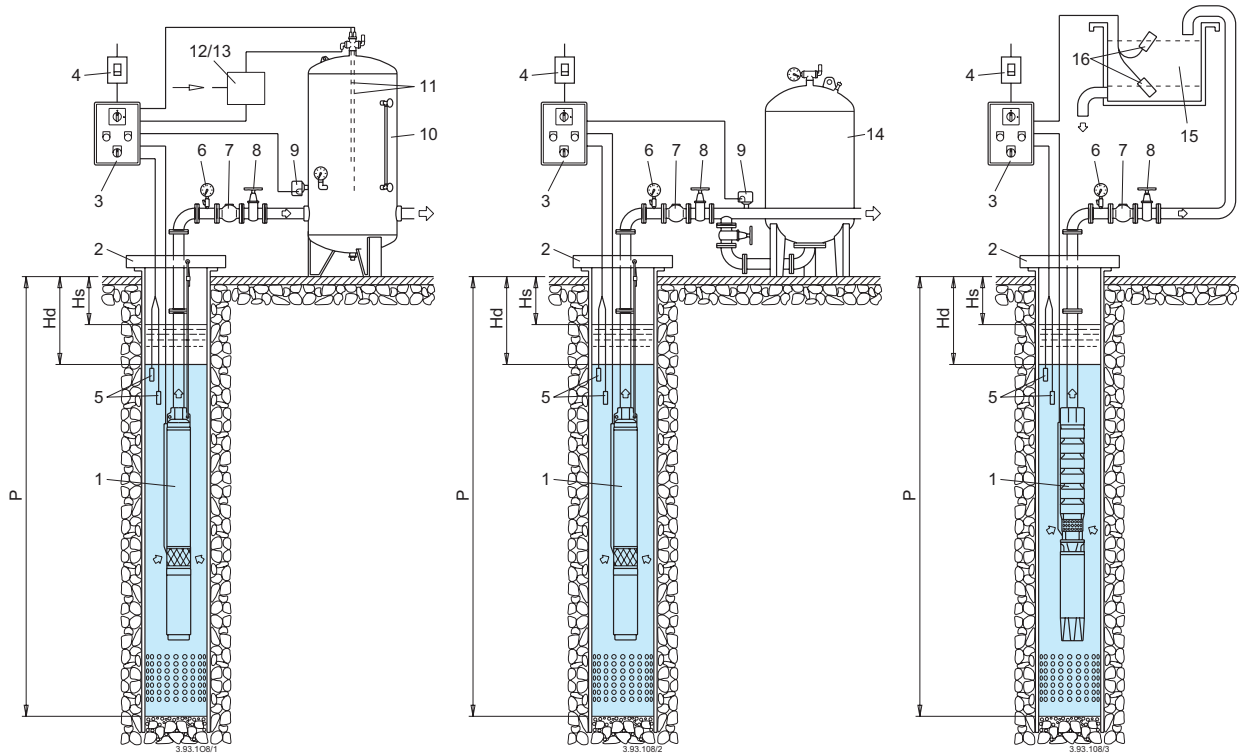

- 1 Submersible pump
- 2 Pump support system
- 3 Electric control board
- 4 Circuit breaker
- 5 Minimum level probes
- 6 Pressure gauge
- 7 Check valve
- 8 Throttle gate valve

- 9 Pressure switch
- 10 Pressure tank
- 11 Probes for air entry control
- 12 Electric valve
- 13 Compressor
- 14 Membrane tank
- 15 Storage tank
- 16 Start-stop probes

- Hs Static level
- Hd Dynamic level
- P Tubewell depth