

POMPE A GIRANTE FLESSIBILE

FLEXIBLE IMPELLER PUMPS

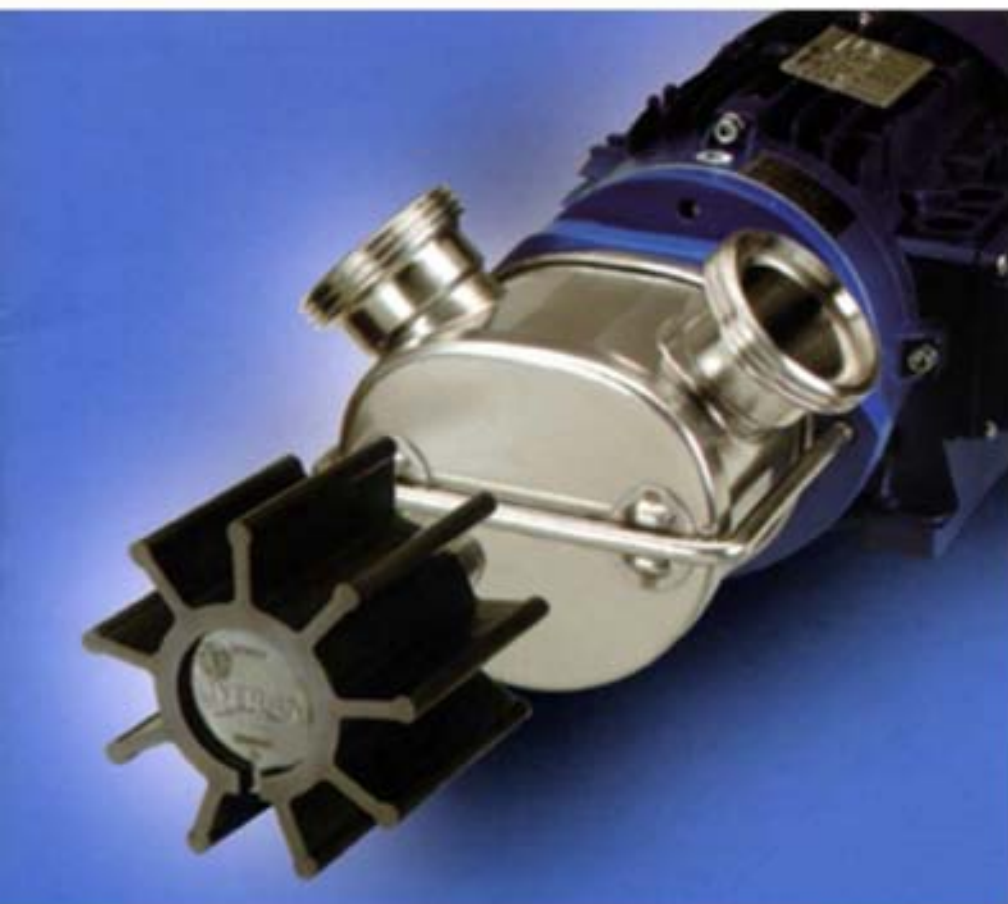

CATALOGO
TECNICO

TECHNICAL
CATALOGUE

LIVERANI

■ ■ ■ Tipologia pompe

<i>Pump range</i>	2-12
Pompe ad asse nudo	2
<i>Bare shaft pumps</i>	2
Pompe con motore idraulico orbitale	2
<i>Hydraulic orbital motor pumps</i>	2
Elettropompe coassiali.....	4
<i>Coaxial pumps</i>	4
Pomp	6
<i>Belt driven pumps on base or trolley</i>	6
Pompe con motoriduttore.....	8
<i>Gearmotor pumps</i>	8
Pompe con variatore o inverter	10
<i>Pumps with mechanical speed variator or frequency converter</i>	10

■ ■ ■ Tabella corrosione giranti

<i>Impeller corrosion table</i>	13-16
---------------------------------------	-------

■ ■ ■ Tabella raccordi

<i>Pipe fittings table</i>	17
----------------------------------	----

■ ■ ■ Quadri elettrici

<i>Control panels</i>	18
-----------------------------	----

■ ■ ■ Accessori

<i>Accessories</i>	19
Valvola by-pass	19
<i>Bypass valve</i>	19
Kit riempi barriques o fusti	19
<i>Kit for barrel filling</i>	19

■ ■ ■ Componenti

<i>Spare parts</i>	20-22
--------------------------	-------

BARE SHAFT PUMPS

HYDRAULIC ORBITAL MOTOR PUMPS



POMPE AD ASSE NUDO (S/P)
BARE SHAFT PUMPS (S/P)



POMPE CON MOTORE IDRAULICO ORBITALE (MID)
HYDRAULIC ORBITAL MOTOR PUMPS (S/P)

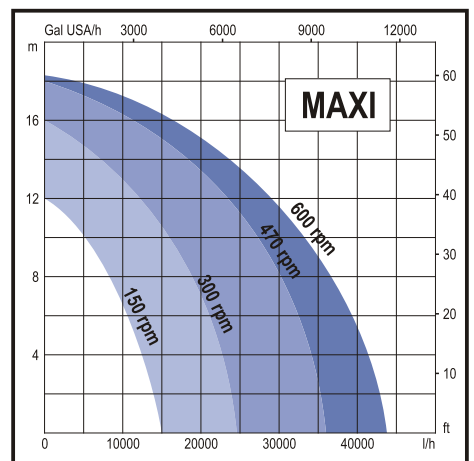
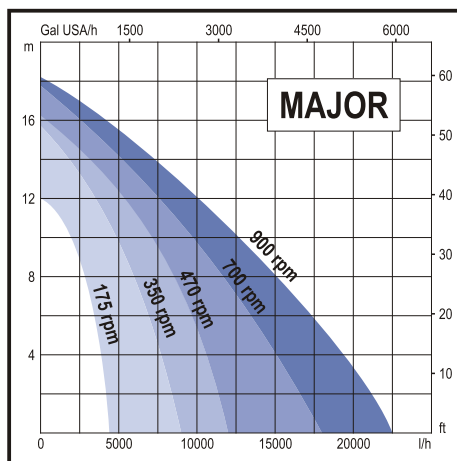
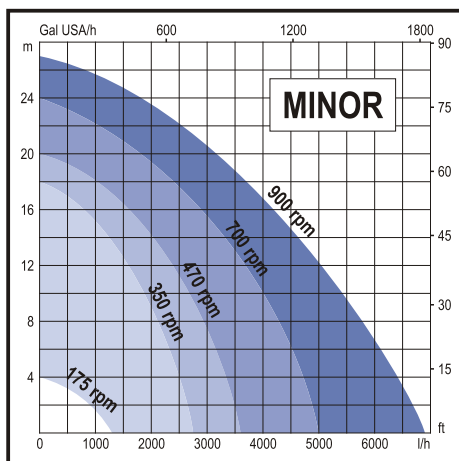

Type	/Weight		/min Rpm	H (m) =				Q (l/h) =				H	
	S/P	MID		0	4	8	12	16	18	20	24		24
MINOR 40	5,4 kg	11,7 kg	min 175	1320	0								Q
			350	2750	2500	2100	1600	800	0				
			470	3600	3300	2900	2400	1600	1000	0			
			700	5000	4700	4300	3700	3000	2520	1800	0		
			max 900	6900	6200	5760	5040	4200	3660	3200	1800	0	
MAJOR 60	9,7 kg	16 kg	min 175	4320	3840	3000	0						Q
			350	9000	7800	6000	3700	0					
			470	12000	10500	8700	5100	0					
			700	18000	15000	12000	8400	2500	0				
			max 900	22500	19560	15000	11220	3000	0				
MAXI 80	15,7 kg	22 kg	min 150	15000	12000	8700	0					Q	
			300	24600	22200	18900	12000	0					
			470	36000	34200	30000	24000	12000	0				
			max 600	43800	41400	36000	30000	16000	0				

MINOR

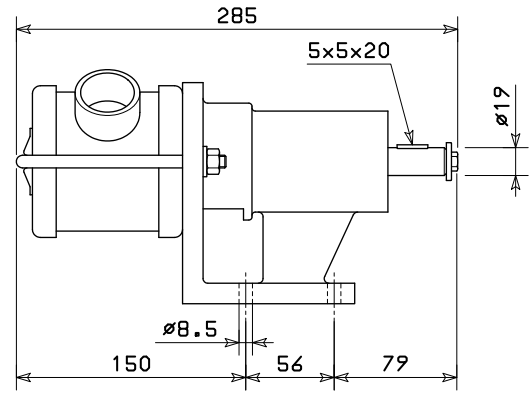
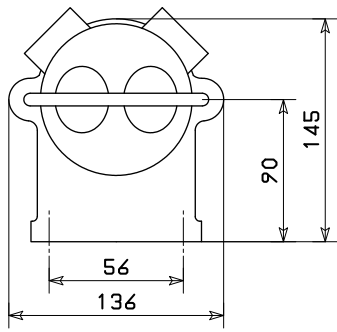

MAJOR

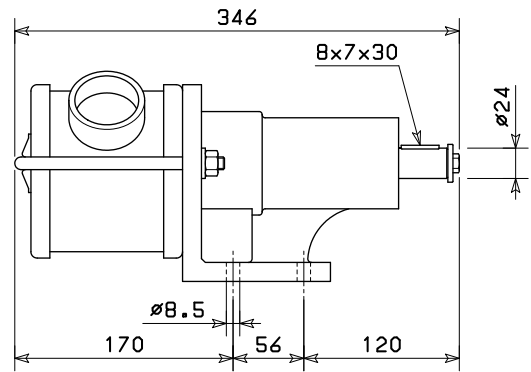
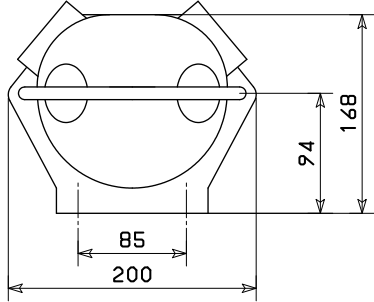

MAXI

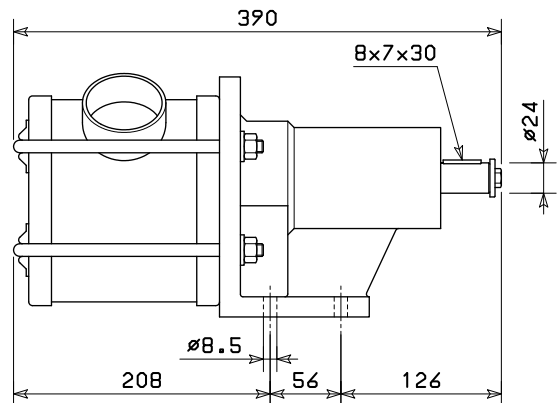
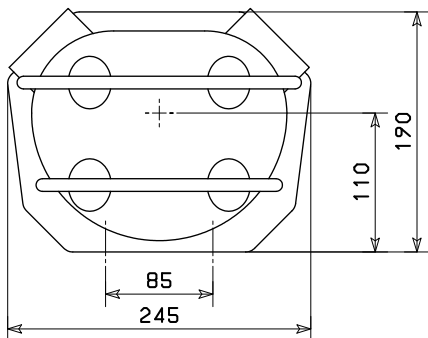

MID

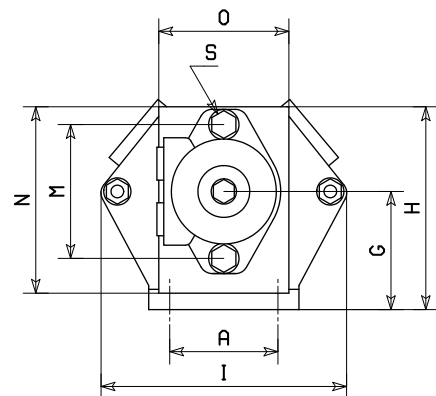
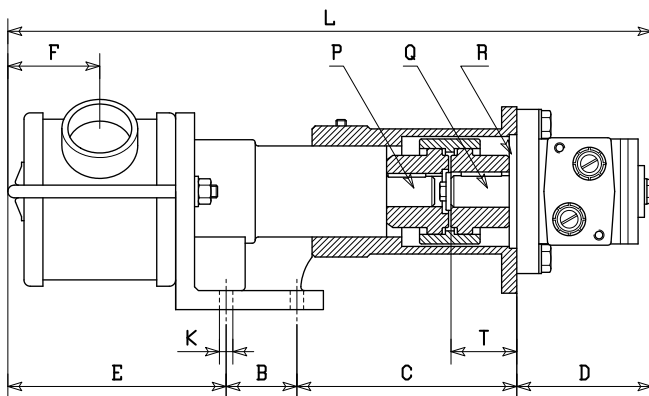

Tipo/Typ	A	B	C	D	E	F	G	H	I	K	L	M	N	O	P	Q	R	S	T
MINOR 40	56	56	141	107	150	60	90	157	136	Ø8.5	454	106	146	103	Ø19	Ø25	Ø82.5	M12	69
MAJOR 60	85	56	175	107	170	70	94	161	200	Ø8.5	508	106	146	103	Ø24	Ø25	Ø90	M12	52
MAXI 80	85	56	182	107	208	90	110	177	240	Ø8.5	553	106	146	103	Ø24	Ø25	Ø90	M12	52

COAXIAL PUMPS



EP MINI 3/4" - MIDEX 1" 1/4



EP MINOR 40 - MAJOR 60 - MAXI 80

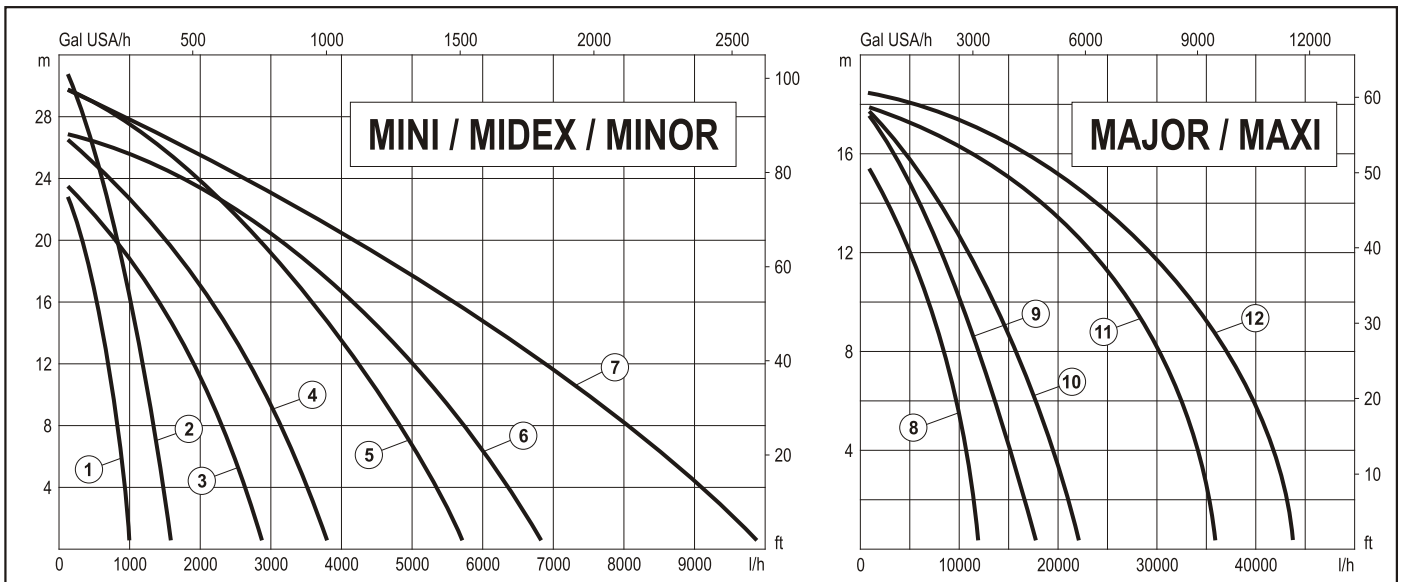

Type	Weight	/Type	HP	kW	Speed	/min Rpm	Ref.	H (m) =								H				
								Q (l/h) =												
								0	4	8	12	16	18	24	27	30	32			
EP MINI 3/4"	9,3 kg	MF TF	0,5	0,37	1	900	1	1000	900	840	720	540	450	0						
	9,0 kg	MF TF	0,75	0,56	1	1400	2	1620	1440	1320	1140	1020	900	600	400	180	0			
	10 kg	CC 12-24V	0,4	0,3	1	1400	2	1620	1440	1320	1140	1020	900	600	400	180	0			
EP MIDEX 1" 1/4	15 kg	MF TF	0,75	0,56	1	900	4	3840	3480	3180	2760	2160	1800	720	0					
	15 kg	MF TF	1	0,75	1	1400	5	5760	5160	4800	4320	3600	3180	1920	1200	0				
	15 kg	TF	0,75	0,56	2	1400	5	5760	5160	4800	4320	3600	3180	1920	1200	0				
	15,4 kg	CC 24V	0,7	0,5	1	900	4	3840	3480	3180	2760	2160	1800	720	0					
EP MINOR 40	20 kg	MF TF	2	1,5	1	900	6	6900	6200	5760	5040	4200	3660	1800	0					
	20 kg	TF	2	1,5	1	1400	7	10000	9000	8000	6900	5500	4900	2600	1700	0				
	27 kg	TF	2,5	1,87	2	1400	7	10000	9000	8000	6900	5500	4900	2600	1700	0				
EP MAJOR 60	38 kg	TF	1,5	1,1	1	470	8	12000	10500	8700	5100	0								
	31 kg	TF	2	1,5	1	700	9	18000	15000	12000	8400	2500	0							
	31 kg	TF	2,5	1,87	1	900	10	22500	19560	15000	11220	3000	0							
EP MAXI 80	68 kg	TF	4,5	3,4	1	470	11	36000	34200	30000	24000	12000	0							
	68 kg	TF	4,5	3,4	1	600	12	43800	41400	36000	30000	16000	0							

* MF = Monofase/Single-phase TF = Trifase/Three-phase CC = Corrente continua/Direct current

Pos.V

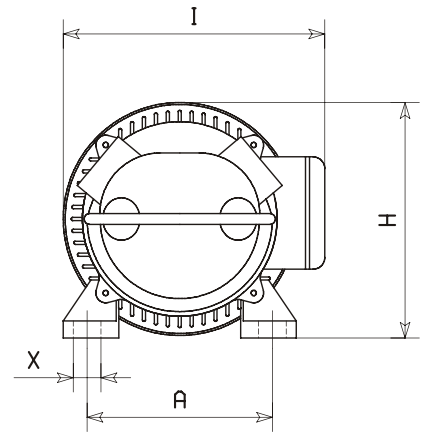
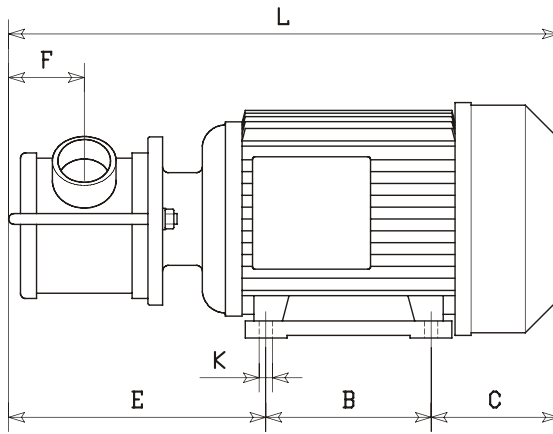

Pos. 90D

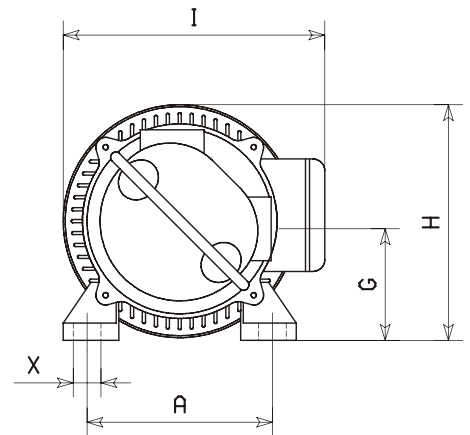
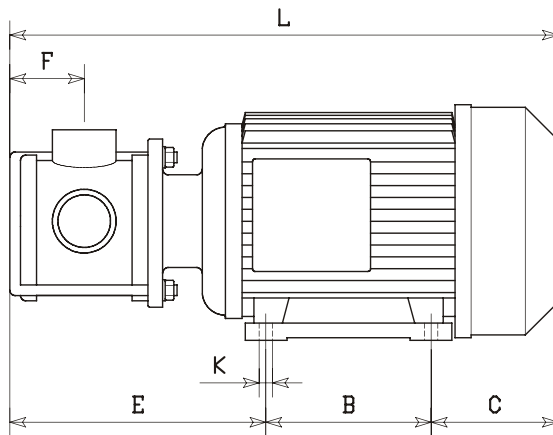

Pos. 90S

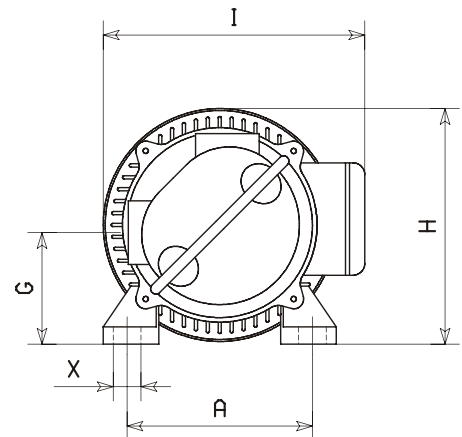
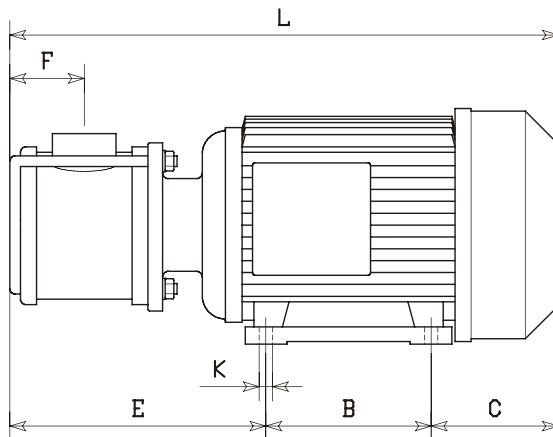

Tipo Typ	/min Rpm		L	H	I	A	B	C	E	F	G	K	X
EP MINI 3/4"	900	1400	276	140	180	112	90	80	106	26	70	7	12
	900	1400	338	159	215	125	100	85	153	38	70	8	16
EP MIDEK 1"1/4	700/1400		338	159	215	125	100	85	153	38	70	8	16
	900	1400	420	180	238	140	125	95	200	60	84	10	16
EP MINOR 40	900/1400		455	198	250	160	140	107	208	60	94	12	21
	700	900	490	198	250	160	140	107	243	70	82	12	21
EP MAJOR 60	470		514	225	275	190	140	115	259	70	82	12	22
	470	600	630	261	330	216	178	143	309	90	115	12	22

BELT DRIVEN PUMPS ON BASE OR TROLLEY

6



GRUPPO A PULEGGIA SU BASE
BELT DRIVEN PUMP ON BASE



GRUPPO A PULEGGIA SU CARRELLO
BELT DRIVEN PUMP ON TROLLEY

Tipo Typ	* Weight *	Motore/Motor **			Speed	/min Rpm	Ref.	H (m) =				Q (l/h) =				H		
		Tipo/Typ	HP	kW				0	4	8	12	16	18	20	24			
GR MINOR 40	36-38 kg	MF TF	2	1,5	I	300	2	2400	2150	1800	1400	700	0				Q	
	36-38 kg	MF TF	2	1,5	I	470	4	3600	3300	2900	2400	1600	1000	0				
	36-38 kg	MF TF	2	1,5	I	700	5	5000	4700	4300	3700	3000	2520	1800	0			
	45-46 kg	TF	2,4	1,8	2	470	4	3600	3300	2900	2400	1600	1000	0				
				1,4	I	235	I	1800	1600	1300	750	0						
	40-41 kg	TF	3	2,2	2	700	5	5000	4700	4300	3700	3000	2520	1800	0			
			2	1,5	2	350	3	2750	2500	2100	1600	800	0					
GR MAJOR 60	42-44 kg	MF TF	2	1,5	I	470	8	12000	10500	8700	5100	0						
	42-44 kg	TF	2,5	1,86	I	700	9	18000	15000	12000	8400	2500	0					
	51-53 kg	TF	2,4	1,8	2	470	8	12000	10500	8700	5100	0						
				1,4	I	235	6	6300	5100	2700	0							
	44-45 kg	TF	3	2,2	2	700	9	18000	15000	12000	8400	2500	0					
			2	1,5	2	350	7	9000	7800	6000	3700	0						
GR MAXI 80	65-67 kg	TF	5,5	4	I	470	10	36000	34200	30000	24000	12000	0					
	65-67 kg	TF	5,5	4	I	600	11	43800	41400	36000	30000	16000	0					

* Gruppo su base - Gruppo su carrello / Group on base - Group on trolley

** MF = Monofase/Single-phase TF = Trifase/Three-phase

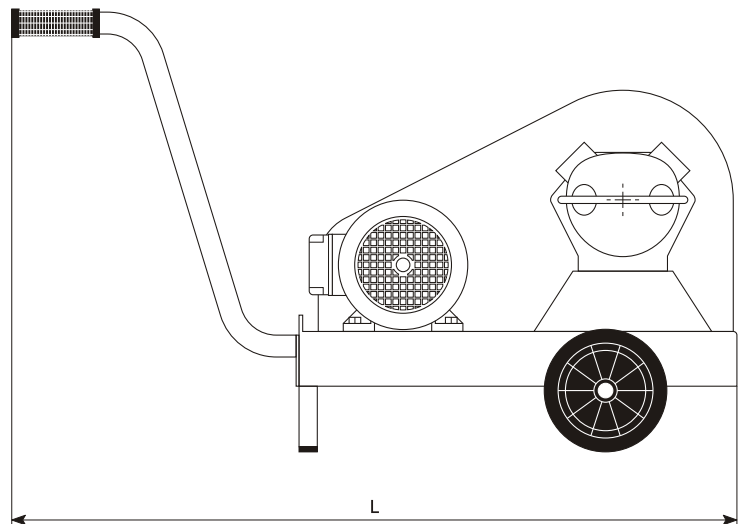
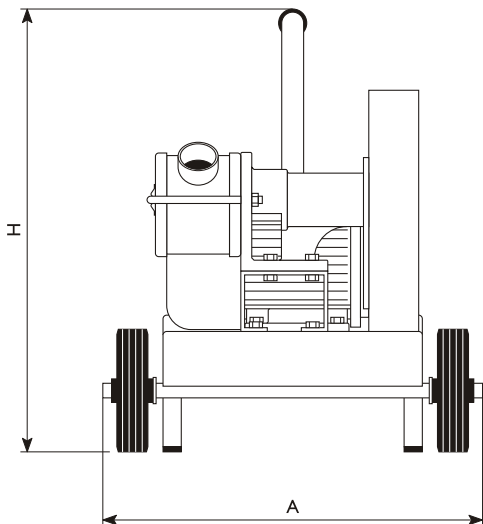
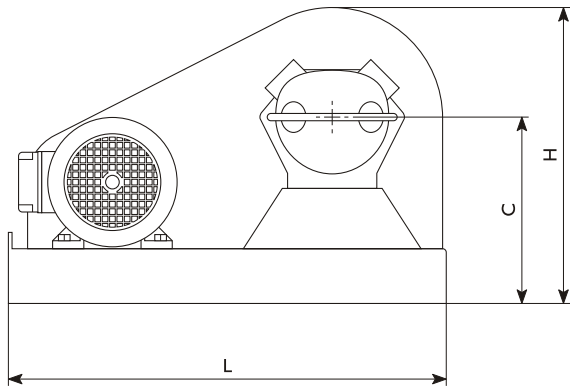
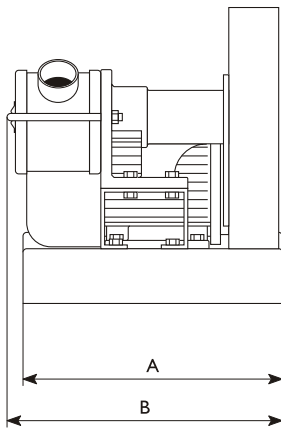
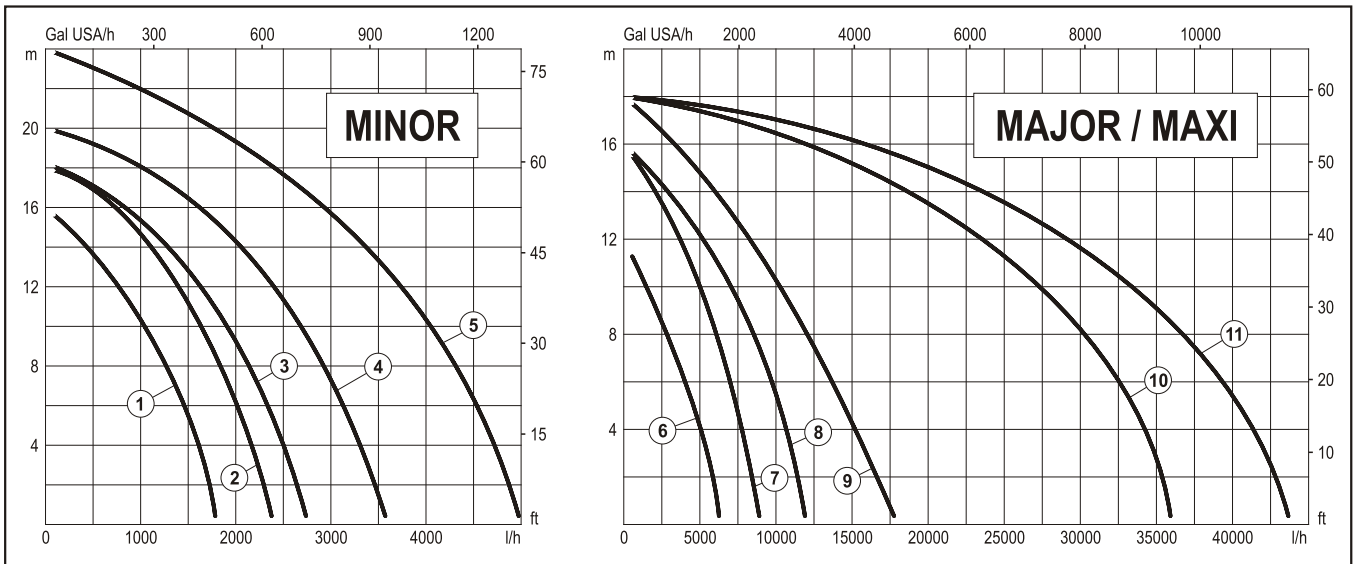

Tipo Typ	/Group on base					/Group on trolley		
	A	B	C	H	L	A	H	L
GR MINOR 40	350	-	245	400	600	500	610	1000
GR MAJOR 60	350	375	250	400	600	500	610	1000
GR MAXI 80	350	430	265	400	600	500	610	1000

PUMPS WITH GEARMOTOR



RID MINOR 40 - MAJOR 60 - MAXI 80



RID MAXI Double



RID MAXI Double 2Q



RID MAXI Double 2H

Tipo Typ	Weight	Motor *			Speed	/min Rpm	Ref.	H (m) =				Q (l/h) =				H		
		Tipo/Typ	HP	kW				0	4	12	16	18	20	24	32		40	
RID MINOR 40	38 kg	TF	2	1,5	1	350	1	2750	2500	1600	800	0						
	38 kg	TF	2	1,5	1	700	2	5000	4700	3700	3000	2520	1800	0				
	38 kg	TF	3	2,2	2	700	2	5000	4700	3700	3000	2520	1800	0				
															2	1,5	1	2750
RID MAJOR 60	48 kg	TF	3	2,2	1	470	5	12000	10500	5100	0							
	48 kg	TF	3	2,2	1	700	6	18000	15000	8400	2500	0						
	48 kg	TF	3	2,2	2	470	5	12000	10500	5100	0							
												2	1,5	3	6300	5100	0	
	48 kg	TF	3	2,2	2	700	6	18000	15000	8400	2500	0						
													2	1,5	4	9000	7800	3700
RID MAXI 80	79 kg	TF	5,5	4	1	470	9	36000	34200	24000	12000	0						
	79 kg	TF	5,5	4	1	600	11	43800	41400	30000	16000	0						
	79 kg	TF	6	4,5	2	470	9	36000	34200	24000	12000	0						
													4,5	3,3	7	19200	18000	9600
	79 kg	TF	6	4,5	2	600	11	43800	41400	30000	16000	0						
													4,5	3,3	8	24600	22200	12000
RID MAXI Double 2Q	185 kg	TF	7,5	5,5	1	470	12	72000	65000	45000	30000	20000	0					
	200 kg	TF	7,5	5,5	2	470	12	72000	65000	45000	30000	20000	0					
4														3	10	36000	33000	20500
RID MAXI Double 2H	185 kg	TF	7,5	5,5	1	470	14	36000	35000	32000	29700	28400	27000	23600	14300	0		
	200 kg	TF	7,5	5,5	2	470	14	36000	35000	32000	29700	28400	27000	23600	14300	0		
4																	3	13

* TF = Trifase/Three-phase

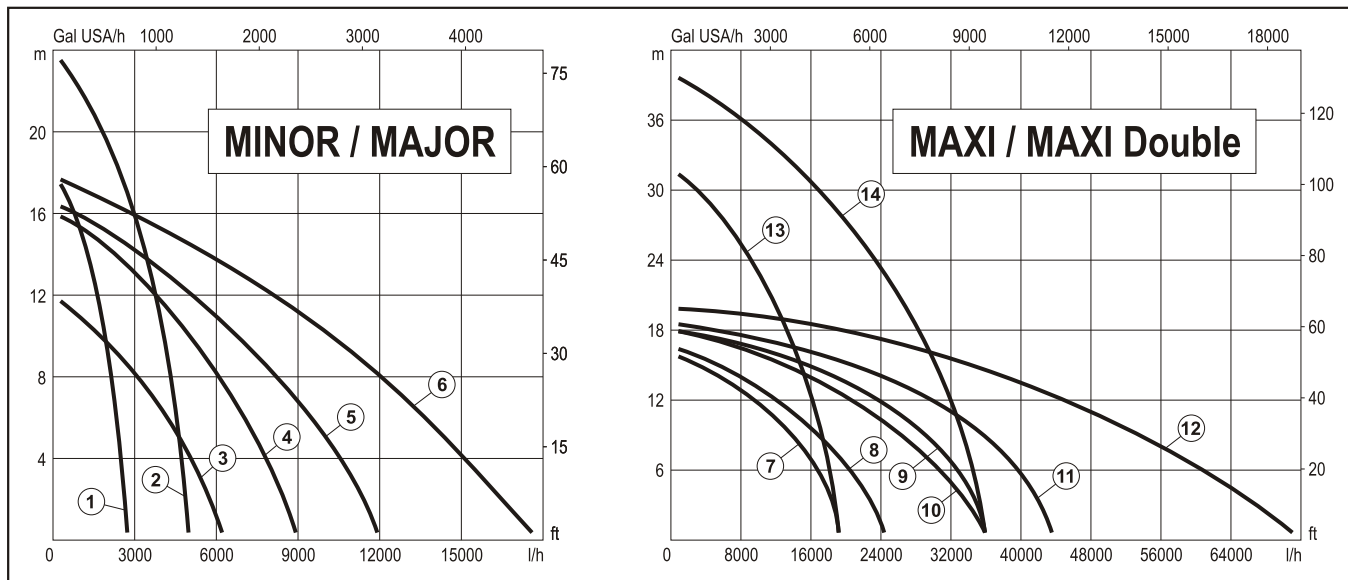

RID MINOR - MAJOR - MAXI

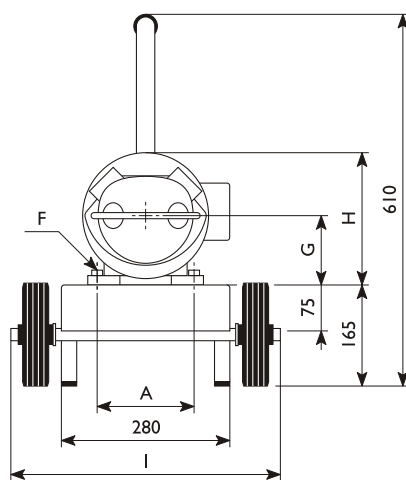
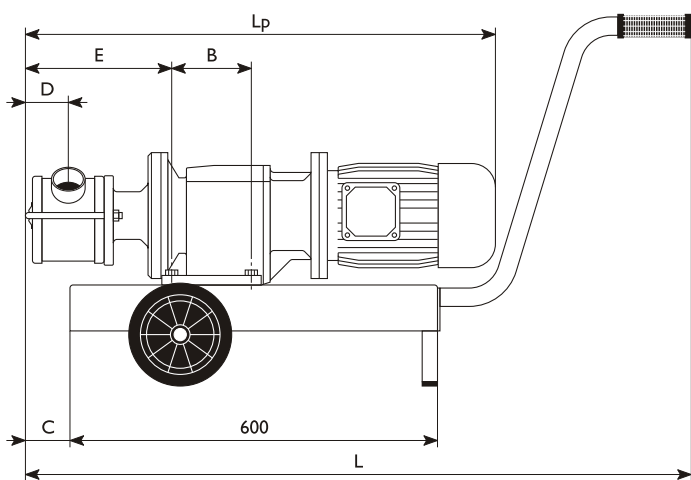

RID MAXI Double

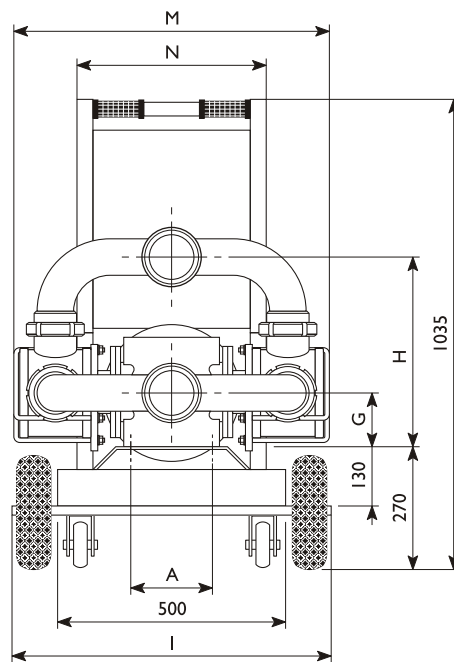
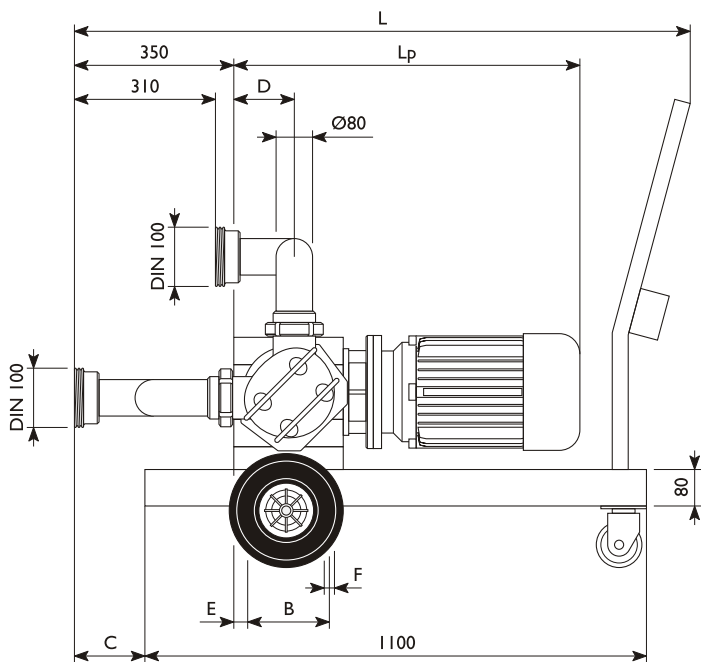

Tipo/Typ	A	B	C	D	E	F	G	H	I	L	Lp	M	N
RID MINOR 40	130	107,5	70	60	183	Ø11	103	202	440	1050	688	-	-
RID MAJOR 60	160	130	135	70	245	Ø11	110	210	440	1145	770	-	-
RID MAXI 80	180	149,5	160	90	255	Ø14	130	255	440	1200	850	-	-
RID MAXI Double	175	170	155	135	35	Ø14	120	416	700	1350	730	695	415

PUMPS WITH MECHANICAL SPEED VARIATOR OR FREQUENCY CONVERTER

10



POMPE CON VARIATORE (VA)
PUMPS WITH MECH. SPEED VARIATOR (VA)

POMPE CON INVERTER (INV)
PUMPS WITH FREQUENCY CONVERTER (INV)

Tipo Typ	/Feeding		/min Rpm	H (m) =					Q (l/h) =					H		
	Tipo/Typ *	HP		kW	0	4	8	12	16	18	20	24	27		32	40
VA MINOR 40	TF 230-400V 50 Hz	2	1,5	min 175	1320	0										
				350	2750	2500	2100	1600	800	0						
				700	5000	4700	4300	3700	3000	2520	1800	0				
				max 900	6900	6200	5760	5040	4200	3660	3200	1800	0			
VA MAJOR 60	TF 230-400V 50 Hz	2,5	1,87	min 175	4320	3840	3000	0								
				350	9000	7800	6000	3700	0							
				700	18000	15000	12000	8400	2500	0						
				max 900	22500	19560	15000	11220	3000	0						
VA MAXI 80	TF 230-400V 50 Hz	5,5	4	min 150	12000	10000	7500	0								
				300	24600	22200	18900	12000	0							
				470	36000	34200	30000	24000	12000	0						
				max 600	43800	41400	36000	30000	16000	0						
INV MINI 3/4"	MF 230V 50 Hz	TF 400V 50 Hz	0,75	0,56	min 180	150	0									
					600	700	560	390	150	0						
					900	1000	900	840	720	540	450	350	0			
					max 1400	1620	1440	1320	1140	1020	900	800	600	400	0	
INV MIDEX 1"1/4	MF 230V 50 Hz	TF 400V 50 Hz	1	0,75	min 180	600	480	0								
					600	2600	2300	2000	1400	800	400	0				
					900	3840	3480	3180	2760	2160	1800	1600	720	0		
					max 1400	5760	5160	4800	4320	3600	3180	2800	1920	1200	0	
INV MINOR 40	MF 230V 50 Hz	TF 400V 50 Hz	2,5	1,87	min 50	380	0									
					175	1320	800	0								
					350	2750	2500	2100	1600	800	0					
					700	5000	4700	4300	3700	3000	2520	1800	0			
INV MAJOR 60	MF 230V 50 Hz	TF 400V 50 Hz	3	2,2	min 900	6900	6200	5760	5040	4200	3660	3200	1800	0		
					max 900	6900	6200	5760	5040	4200	3660	3200	1800	0		
					min 50	1230	0									
					175	4320	3840	3000	0							
INV MAXI 80	TF 230V 50 Hz	TF 400V 50 Hz	5,5	4	350	9000	7800	6000	3700	0						
					700	18000	15000	12000	8400	2500	0					
					max 900	22500	19560	15000	11220	3000	0					
					min 50	3800	0									
INV MAXI Double 2Q	TF 230V 50 Hz	TF 400V 50 Hz	7,5	5,5	150	12000	10000	7500	0							
					300	24600	22200	18900	12000	0						
					470	36000	34200	30000	24000	12000	0					
					max 600	43800	41400	36000	30000	16000	0					
INV MAXI Double 2H	TF 230V 50 Hz	TF 400V 50 Hz	7,5	5,5	min 50	7600	0									
					175	27000	24000	20000	13000	0						
					235	36000	33000	27500	20500	10000	0					
					350	54000	48500	41500	33000	22000	14000	0				
INV MAXI Double 2H	TF 230V 50 Hz	TF 400V 50 Hz	7,5	5,5	max 470	72000	65000	56000	45000	30000	20000	0				
					min 50	3800	2000	0								
					175	14100	13500	12600	11400	9700	8600	7400	4500	0		
					235	19200	18500	17500	16200	14300	13200	12000	9000	5900	0	
INV MAXI Double 2H	TF 230V 50 Hz	TF 400V 50 Hz	7,5	5,5	350	27600	26700	25500	24000	22200	21000	20000	17200	14800	9700	0
					max 470	36000	35000	33600	32000	29700	28400	27000	23600	20600	14300	0

* MF = Monofase/Single-phase TF = Trifase/Three-phase

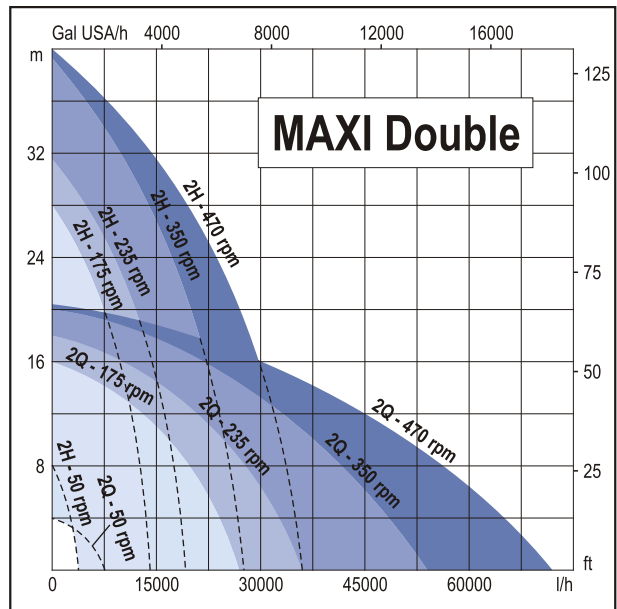
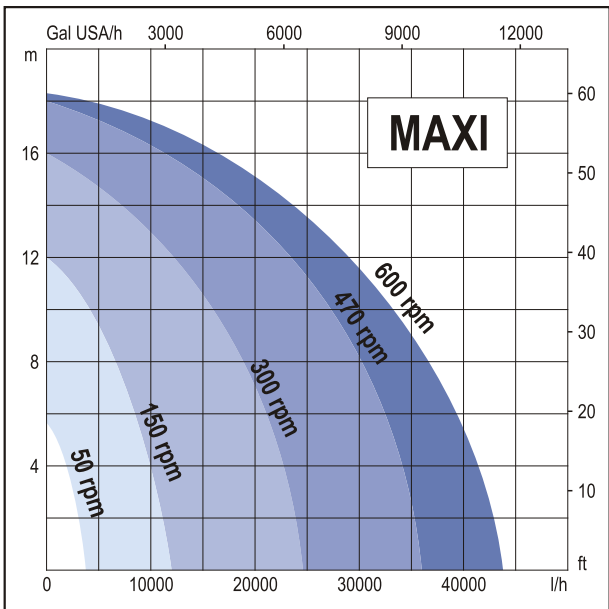
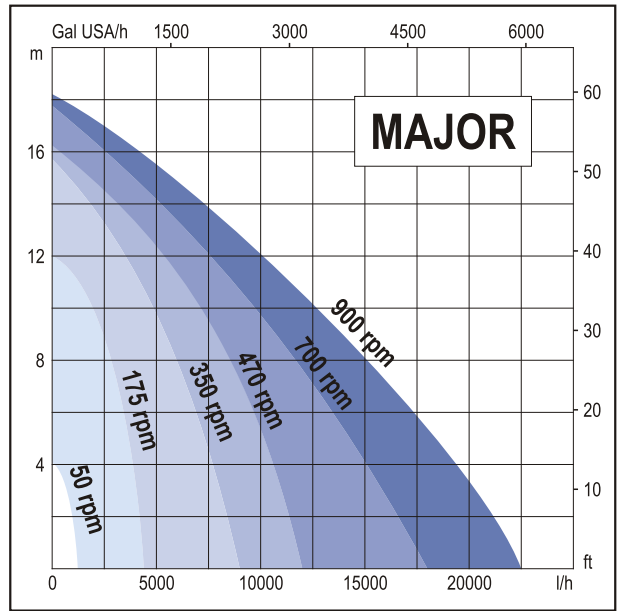
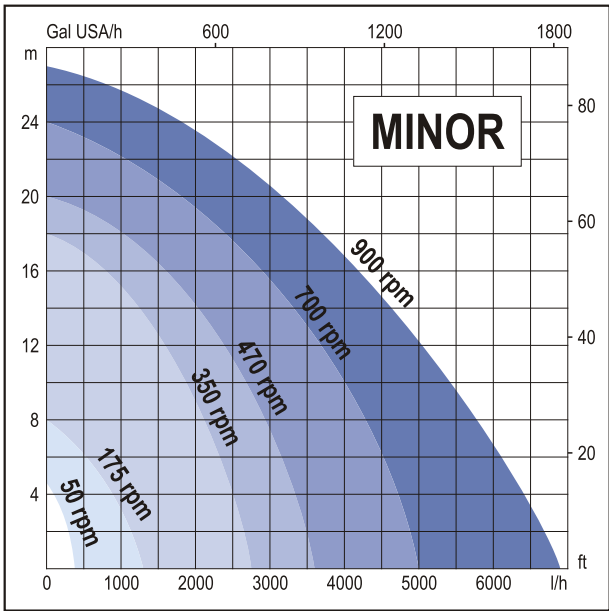
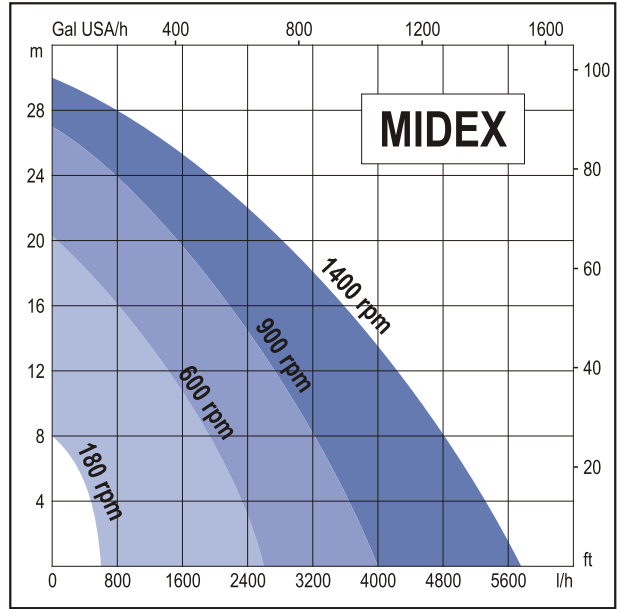
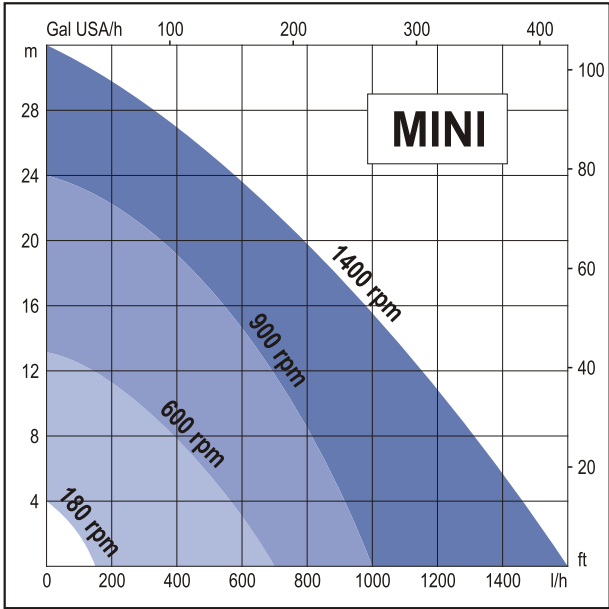

VA MINOR - MAJOR - MAXI

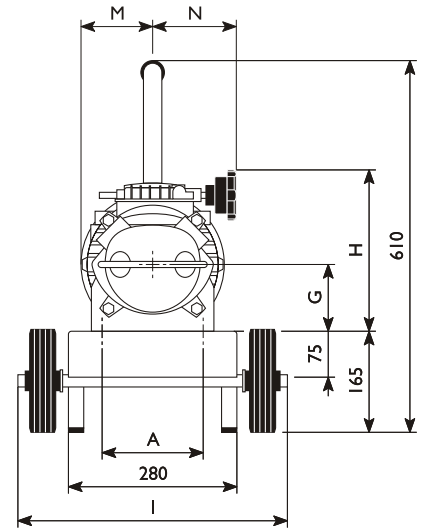
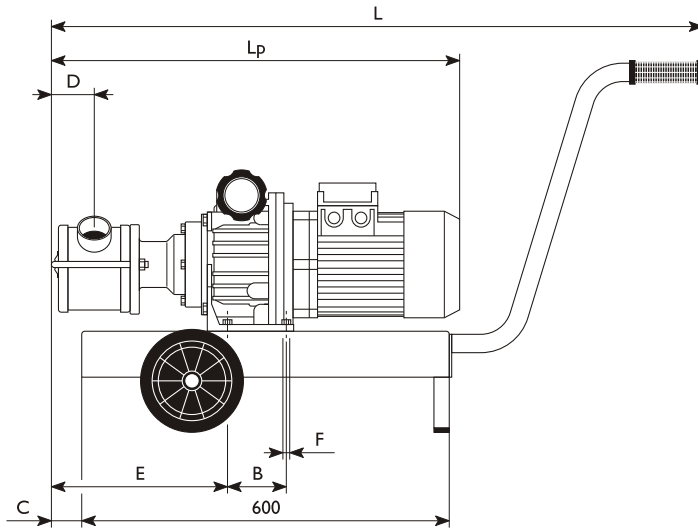

INV MINI - MIDEX

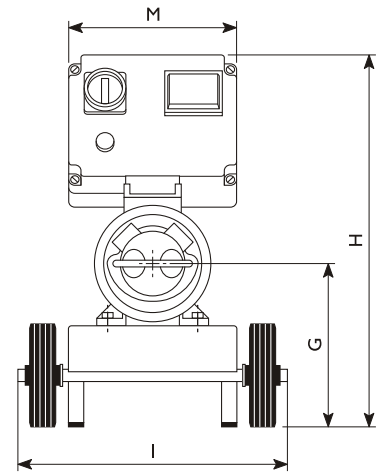
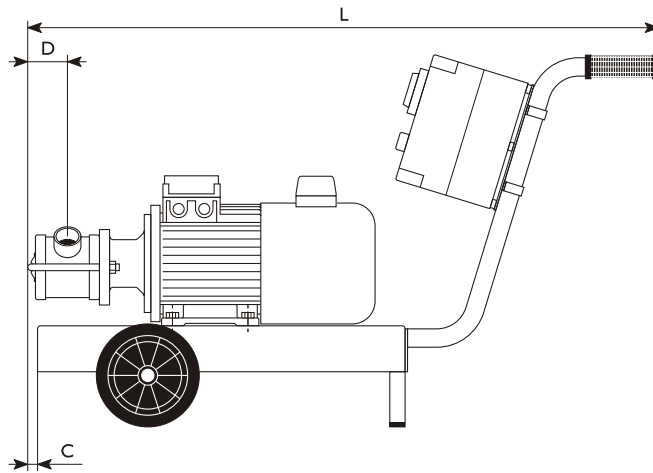

INV MINOR - MAJOR - MAXI

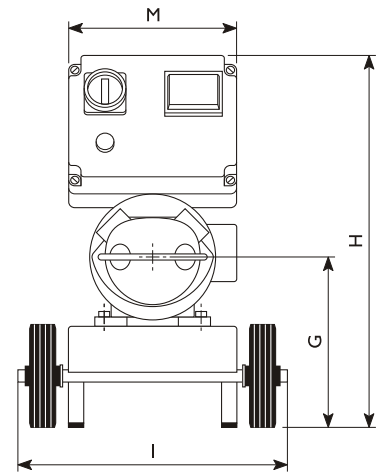
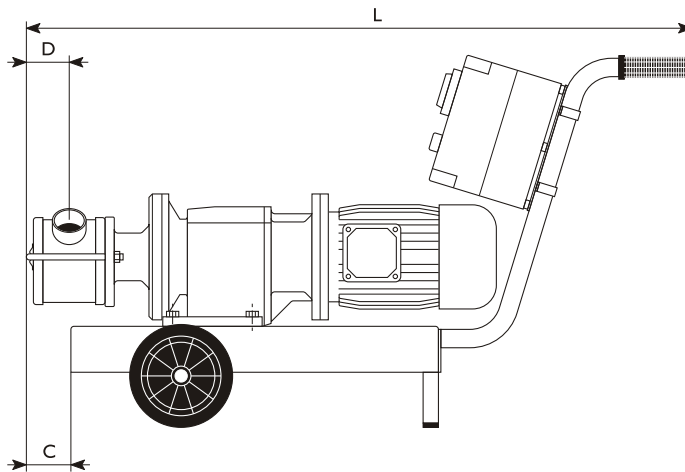

Tipo/Type	/Weight	A	B	C	D	E	F	G	H	I	L	Lp	M	N
VA MINOR 40	63 kg	164	96	20	60	260	Ø11	109	264	440	1030	640	117	137
VA MAJOR 60	67 kg	164	96	55	70	295	Ø11	109	264	440	1065	675	117	137
VA MAXI 80	109 kg	200	120	115	90	305	M12	132	337	440	1125	770	136	172,5
INV MINI 3/4"	17 kg	-	-	-	26	-	-	175	550	340	790	-	285	-
INV MIDEX 1"1/4	23 kg	-	-	15	38	-	-	175	550	340	805	-	285	-
INV MINOR 40	45 kg	-	-	70	60	-	-	268	610	440	1050	-	285	-
INV MAJOR 60	55 kg	-	-	135	70	-	-	275	610	440	1145	-	285	-
INV MAXI 80	95 kg	-	-	160	90	-	-	295	610	440	1200	-	285	-
INV MAXI Double 2Q/2H	185/200 kg	Dimensioni p.9 / Dimensions p.9												

IMPELLER CORROSION TABLE

		Material
NBR	Nitrile	Nitrile
EPDM	Epdm	Epdm
CR	Neoprene	Neoprene rubber
NR	Gomma naturale	Natural rubber
VMQ	Silicone	Silicon

		Characteristic
A	Ottimo	Excellent
B	Discreto/Buono	Fair/Good
C	Sconsigliato/Scarso	Not advisable/Poor
*	Variabile	Variable
-	Non disponibile	Not available

Le temperature riportate tra parentesi sono da considerarsi come temperature massime di utilizzo. La temperatura di 20° C rappresenta all'incirca la temperatura ambiente.

Il termine "Variabile" indica che all'interno della stessa famiglia di polimeri si possono avere comportamenti diversi in funzione del tipo di polimero, della concentrazione del prodotto e della temperatura di utilizzo.

Temperatures reported in parentheses must be considered the highest temperatures that can be used. The temperature of 20° C corresponds to an average room temperature.

The term "Variable" means that within the same family of polymers there can be different behaviours according to the kind of polymer, the concentration of the product and the temperature at which it is used.















Prodotto	NBR	EPDM	CR	NR	VMQ
Acetato di etile	C	A (55° C) C (70° C)	C	C	B (20° C)
Aceto	B (20° C) * (60° C)	A (60-90° C)	B (90° C)	B (20° C)	A (20° C)
Acido Acetico (30%)	B (20° C)	A	B (20° C)	B (20° C)	-
Acido Borico	A (60° C) B (90° C)	A (60° C) B (90° C)	A (70° C) B (90° C)	A (20° C) B (85° C)	A (20° C)
Acido Bromico (40%)	C	A (90° C)	*	B (20° C)	C
Acido Cianidrico	B (60° C)	A (60° C)	*	-	B (20° C)
Acido Citrico	A (90° C) B (100° C)	A	A	A (20° C)	A (20° C)
Acido Cloridrico concentrato	C	C	C	*	C
Acido Cloroacetico	C	B (70-90° C)	A (20° C) C (40° C)	*	*
Acido Cromico	C	B	*	*	*
Acido Fluoridrico (50%)	C	B (60° C)	*	C (20° C)	*
Acido Fluoridrico concentrato	C	C	C	C	C
Acido Fluoroborico	A (60° C) B (85° C)	A (60° C) B (80° C)	A (60° C) B (85° C)	A (20° C) B (65° C)	A (20° C)
Acido Formico	*	A (90° C)	*	B (20° C)	B (20° C)
Acido Fosforico (85%)	C	A (80° C)	A (40° C)	B (65° C)	C
Acido Lattico concentrato	A (20° C)	A (60° C)	A (20° C) B (60° C) C (80° C)	-	-
Acido Nitrico (10%)	C	A (40° C) C (80° C)	C (40° C)	C	B (20° C)
Acido Nitrico (70%)	-	C	C	C	C
Acido Ossalico concentrato	B (60° C)	A (120° C)	B (60° C)	B (20° C)	B (20° C)
Acido Palmitico	A (70° C)	B (20° C)	B (20-70° C)	B (20° C)	C
Acido Picrico	C	A (20° C)	B (20° C)	C	C
Acido Picrico (10%)	B (70° C)	B (90° C)	A (20° C) C (40° C)	B (20° C)	C
Acido Solforico (50%)	A (20° C) C (80° C)	B (60-80° C)	B (70° C)	B (26° C)	*

Prodotto	NBR	EPDM	CR	NR	VMQ
Acido Solforico (80%)	B (40° C) C (60-80° C)	A (60° C) C (80° C)	C	C	C
Acido Stearico	A (120° C)	B (60° C)	B (60-70° C)	*	B (20° C)
Acqua	A (80° C)	A (135° C)	B (100° C)	A (20° C) B (80° C)	B (80° C)
Alcol Benzilico	C	B (40° C) C (60° C)	*	C	-
Alcol Etilico	A (60° C) B (85° C)	A (90° C)	A (70° C) B (80° C)	A (20° C) B (65° C)	B (20° C)
Alcol Metilico	B (65° C)	A (70° C) B (80° C)	A (60° C) B (80° C)	B (37° C)	A (70° C)
Alcol Propilico	B (90° C)	B (90° C)	A (60° C) B (90° C)	A (20° C) B (65° C)	A (20° C)
Ammonio Idrato concentrato (38%)	A (90° C)	-	A (90° C)	A (65° C)	-
Anidride Solforosa	C	C (20° C)	C (20° C)	C	A (20° C)
Anilina	C	A (90° C)	C	C	B (20° C)
Benzina	A (120° C)	C	C	C	C
Birra	A (60° C) B (120° C)	A (60° C) B (80° C)	A (60° C)	A (20° C)	A (20° C)
Bromo gas	C	C	C	C	C
Burro	A (60° C)	A (60° C)	B (20° C) C (60° C)	C	B (20° C)
Butadiene	*	*	*	C	C
Butano	A (90° C) B (120° C)	C	A (60° C)	C	C
Calcio Idrato	A (20° C) B (90° C)	A (20° C)	A (20° C) B (90° C)	A (20° C) B (65° C)	A (20° C)
Calcio Ipoclorito	C	A (120° C)	C	C	B (20° C)
Cherosene	A (120° C)	C	B (20° C)	C	C
Cloro Umido	C	*	C	C	C
Cloroformio	C	C	C	C	C
Gelatina	A (90° C)	A (80° C)	A (60° C) B (80° C)	A (20° C) B (65° C)	A (20° C)
Glicerina	A (120° C)	A (80° C) B (90° C)	A (70° C)	A (20° C) B (65° C)	A (20° C)
Glucosio	A (90° C)	A (80° C)	A (60° C)	A (20° C) B (48° C)	A (20° C)
Iodio	B (60° C) A (20° C) 6,5%	B (70° C) A (20° C) 6,5%	C	C	C
Latte	A (60° C)	A (120° C)	A (60° C)	A (20° C) B (37° C)	A (20° C)
Magnesio Cloruro	A (80° C) B (100° C)	A (80° C) B (100° C)	A (80° C) B (100° C)	A (20° C) B (85° C)	A (20° C)
Magnesio Solfato	A (80° C) B (100° C)	A (80° C) B (100° C)	A (80° C) B (90° C)	B (85° C)	A (20° C)
Mercurio	A (60° C)	A (60° C)	A (60° C)	A (20° C)	A (20° C)
Metiltilchetone	C	A (60° C) B (90° C)	C	C	C
Nafta	A (120° C)	C	C	C	C
Olio di Anilina	C	B (20° C)	C	C	C
Olio di Cotone	A (90° C) B (100° C)	A (20° C) C (80° C)	B (65° C)	C	A (20° C)
Olio di fegato di merluzzo	A (20° C) B (50° C)	A (20° C)	B (20° C)	C	B (20° C)
Olio di Granoturco	A (120° C)	*	B (20° C)	C	A (20° C)
Olio di Lino	A (90° C)	B (20° C)	B (80° C)	C	C
Olio di Oliva	A (120° C)	B (20° C)	*	C	*
Olio di Pino	B (120° C)	C	C	C	C
Olio di Ricino	A (100° C)	A (60° C)	A (70° C)	A (25° C)	A (20° C)
Olio di Soia	A (120° C)	*	B (20° C)	C	C
Olio Idraulico (esteri fosforici)	C	A (120° C)	C	C	*
Olio SAE n.10	A (120° C)	C	*	C	*
Olio vegetale	A (90° C)	*	C (20° C)	C	A (20° C)
Paraffina	A (60° C)	C	B (20° C)	*	C
Percloroetilene	*	C	C	C	*
Sodio Cloruro	A (70° C)	B (90° C)	A (100° C)	A (65° C)	B
Sodio Idrato	B (65° C)	A (20° C)	B (90° C)	A (20° C) B (65° C)	C (20° C)
Succo di frutta	A (60° C)	A (120° C)	A (60° C)	*	A (20° C)
Succo di pomodoro	A (60° C)	A (20° C)	A (60° C)	-	-

Prodotto	NBR	EPDM	CR	NR	VMQ
Toluolo	C	C	C	C	C
Tricloroetilene	C	C	C	C	C
Trietanolammina	C (20° C) 100% B (37° C) 80%	A (70° C)	A (70° C)	B (26° C)	C
Vino	A (90° C)	A (90° C)	A (90° C)	A (20° C) B (65° C)	A (20° C)
Whisky	A (90° C)	A (90° C)	A (60° C) C (90° C)	A (20° C) B (65° C)	A (20° C)
Xilolo	C	C	C	C	C
Zolfo fuso 120° C	C	A (120° C)	A (20° C)	C (20° C)	A (20° C) C (120° C)
Zucchero di canna	A (60° C) B (90° C)	A (80° C)	A (20° C) B (90° C)	A (20° C)	A (20° C)

	NBR	EPDM	CR	NR	VMQ
Acetic Acid (30%)	B (20° C)	A	B (20° C)	B (20° C)	-
Ammonium Hydroxide (38%)	A (90° C)	-	A (90° C)	A (65° C)	-
Aniline	C	A (90° C)	C	C	B (20° C)
Aniline Oil	C	B (20° C)	C	C	C
Beer	A (60° C) B (120° C)	A (60° C) B (80° C)	A (60° C)	A (20° C)	A (20° C)
Benzyl Alcohol	C	B (40° C) C (60° C)	*	C	-
Boric Acid	A (60° C) B (90° C)	A (60° C) B (90° C)	A (70° C) B (90° C)	A (20° C) B (85° C)	A (20° C)
Bromic Acid (40%)	C	A (90° C)	*	B (20° C)	C
Butadiene	*	*	*	C	C
Butane	A (90° C) B (120° C)	C	A (60° C)	C	C
Butter	A (60° C)	A (60° C)	B (20° C) C (60° C)	C	B (20° C)
Calcium Hydrate	A (20° C) B (90° C)	A (20° C)	A (20° C) B (90° C)	A (20° C) B (65° C)	A (20° C)
Calcium Hypochlorite	C	A (120° C)	C	C	B (20° C)
Cane Sugar liquide	A (60° C) B (90° C)	A (80° C)	A (20° C) B (90° C)	A (20° C)	A (20° C)
Castor Oil	A (100° C)	A (60° C)	A (70° C)	A (25° C)	A (20° C)
Chlorine (damp)	C	*	C	C	C
Chloroacetic Acid		B (70-90° C)	A (20° C) C (40° C)	*	*
Chloroform	C	C	C	C	C
Chromic Acid	C	B	*	*	*
Citric Acid	A (90° C) B (100° C)	A	A	A (20° C)	A (20° C)
Cod-Liver Oil	A (20° C) B (50° C)	A (20° C)	B (20° C)	C	B (20° C)
Corn Oil	A (120° C)	*	B (20° C)	C	A (20° C)
Cotton Oil	A (90° C) B (100° C)	A (20° C) C (80° C)	B (65° C)	C	A (20° C)
Diesel Oil	A (120° C)	C	C	C	C
Ethyl Acetate	C	A (55° C) C (70° C)	C	C	B (20° C)
Ethyl Alcohol	A (60° C) B (85° C)	A (90° C)	A (70° C) B (80° C)	A (20° C) B (65° C)	B (20° C)
Fluoboric Acid	A (60° C) B (85° C)	A (60° C) B (80° C)	A (60° C) B (85° C)	A (20° C) B (65° C)	A (20° C)
Formic Acid	*	A (90° C)	*	B (20° C)	B (20° C)
Fruit Juices	A (60° C)	A (120° C)	A (60° C)	*	A (20° C)
Gelatine	A (90° C)	A (80° C)	A (60° C) B (80° C)	A (20° C) B (65° C)	A (20° C)
Glucose	A (90° C)	A (80° C)	A (60° C)	A (20° C) B (48° C)	A (20° C)
Glycerine	A (120° C)	A (80° C) B (90° C)	A (70° C)	A (20° C) B (65° C)	A (20° C)

	NBR	EPDM	CR	NR	VMQ
Hydraulic Oil	C	A (120° C)	C	C	*
Hydrochloric Acid (concentrated)	C	C	C	*	C
Hydrocyanic Acid	B (60° C)	A (60° C)	*	B (20° C)	B (20° C)
Hydrofluoric Acid (50%)	C	B (60° C)	*	C (20° C)	*
Hydrofluoric Acid (concentrated)	C	C	C	C	C
Iodine	B (60° C) A (20° C) 6,5%	B (70° C) A (20° C) 6,5%	C	C	C
Kerosene	A (120° C)	C	B (20° C)	C	C
Lactic Acid (concentrated)	A (20° C)	A (60° C)	A (20° C) B (60° C) C (80° C)	-	-
Linseed Oil	A (90° C)	B (20° C)	B (80° C)	C	C
Magnesium Chloride	A (80° C) B (100° C)	A (80° C) B (100° C)	A (80° C) B (100° C)	A (20° C) B (85° C)	A (20° C)
Magnesium Sulphate	A (80° C) B (100° C)	A (80° C) B (100° C)	A (80° C) B (90° C)	B (85° C)	A (20° C)
Mercury	A (60° C)	A (60° C)	A (60° C)	A (20° C)	A (20° C)
Methyl Alcohol	B (65° C)	A (70° C) B (80° C)	A (60° C) B (80° C)	B (37° C)	A (70° C)
Methyl-ethyl-ketone	C	A (60° C) B (90° C)	C	C	C
Milk	A (60° C)	A (120° C)	A (60° C)	A (20° C) B (37° C)	A (20° C)
Nitric Acid (10%)	C	A (40° C) C (80° C)	C (40° C)	C	B (20° C)
Nitric Acid (70%)	-	C	C	C	C
Olive Oil	A (120° C)	B (20° C)	*	C	*
Oxalic Acid (concentrated)	B (60° C)	A (120° C)	B (60° C)	B (20° C)	B (20° C)
Palmitic Acid	A (70° C)	B (20° C)	B (20-70° C)	B (20° C)	C
Paraffin	A (60° C)	C	B (20° C)	*	C
Perchloroethylen	*	C	C	C	*
Petrol	A (120° C)	C	C	C	C
Phosphoric Acid (85%)	C	A (80° C)	A (40° C)	B (65° C)	C
Picric Acid	C	A (20° C)	B (20° C)	C	C
Picric Acid (10%)	B (70° C)	B (90° C)	A (20° C) C (40° C)	B (20° C)	C
Pine Oil	B (120° C)	C	C	C	C
Propylic Alcohol	B (90° C)	B (90° C)	A (60° C) B (90° C)	A (20° C) B (65° C)	A (20° C)
SAE n. 10 Oil	A (120° C)	C	*	C	*
Sodium Chloride	A (70° C)	B (90° C)	A (100° C)	A (65° C)	B
Sodium Hydrate	B (65° C)	A (20° C)	B (90° C)	A (20° C) B (65° C)	C (20° C)
Soybean Oil	A (120° C)	*	B (20° C)	C	C
Stearic Acid	A (120° C)	B (60° C)	B (60-70° C)	*	B (20° C)
Sulphur (fused 120° C)	C	A (120° C)	A (20° C)	C (20° C)	A (20° C) C (120° C)
Sulphur Dioxide	C	C (20° C)	C (20° C)	C	A (20° C)
Sulphuric Acid (50%)	A (20° C) C (80° C)	B (60-80° C)	A (70° C)	B (26° C)	*
Sulphuric Acid (80%)	B (40° C) C (60-80° C)	A (60° C) C (80° C)	C	C	C
Toluol	C	C	C	C	C
Tomatoes Juices	A (60° C)	A (20° C)	A (60° C)	-	-
Trichloroethylene	C	C	C	C	C
Triethanolamine	C (20° C) 100% B (37° C) 80%	A (70° C)	A (70° C)	B (26° C)	C
Vegetable Oil	A (90° C)	*	C (20° C)	C	A (20° C)
Vinegar	B (20° C) * (60° C)	A (60-90° C)	B (90° C)	B (20° C)	A (20° C)
Water	A (80° C)	A (135° C)	B (100° C)	A (20° C) B (80° C)	B (80° C)
Whisky	A (90° C)	A (90° C)	A (60° C) C (90° C)	A (20° C) B (65° C)	A (20° C)
Wine	A (90° C)	A (90° C)	A (90° C)	A (20° C) B (65° C)	A (20° C)
Xylol	C	C	C	C	C

Tipo Typ		MINI	MIDEX	MINOR	MAJOR	MAXI
						
Garolla		<i>Non disponibile Not available</i>	Garolla 40	Garolla 40 Garolla 50	Garolla 50 Garolla 60 Garolla 70	Garolla 70 Garolla 80 Garolla 100
DIN 11851		DIN 25	DIN 32 DIN 40	DIN 40 DIN 50	DIN 50 DIN 65	DIN 65 DIN 80 DIN 100
BSP-M		BSP-M 3/4"	BSP-M 1"1/4	BSP-M 1"1/4 BSP-M 1"1/2	BSP-M 2"	BSP-M 2"1/2 BSP-M 3"
BSP-F		<i>Non disponibile Not available</i>	BSP-F 1"	BSP-F 1" BSP-F 1"1/4	BSP-F 1"1/2 BSP-F 2"	BSP-F 2"1/2 BSP-F 3"
Macon		<i>Non disponibile Not available</i>	Macon 40	Macon 40 Macon 50	Macon 40 Macon 50	Macon 70
Triclover		Triclover 1"	Triclover 1"1/2	Triclover 1"1/2	Triclover 2"	Triclover 3"
SMS		SMS 25	SMS 38	SMS 38	SMS 51	SMS 76
BSM (RJT)		BSM 1"	BSM 1"1/2	BSM 1"1/2	BSM 2" BSM 2"1/2	BSM 3"
Friederich		<i>Non disponibile Not available</i>	Friederich 40	Friederich 40	Friederich 40 Friederich 60	Friederich 60

CONTROL PANELS

18

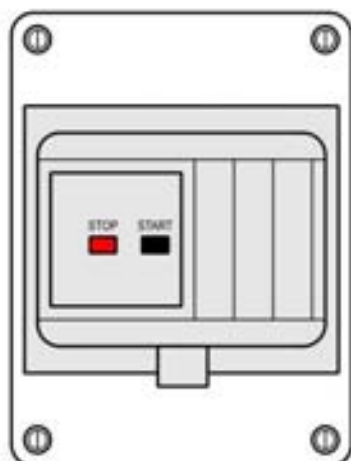

Impianto elettrico CE
CE control panel

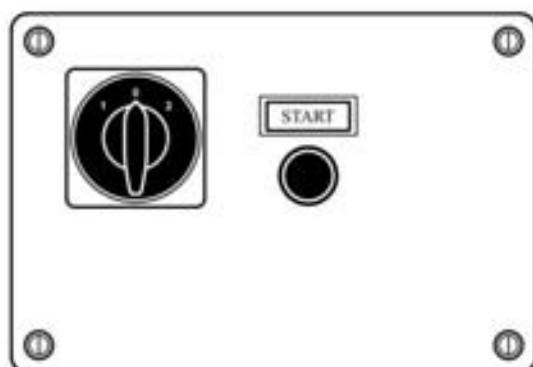

Impianto elettrico CE con derivazione
supplementare 24V NC per sensore di temperatura,
pressostato, sensore di livello, ecc.
CE control panel with supplementary 24V NC shunt trip
for temperature sensor, pressure switch, level sensor, etc...

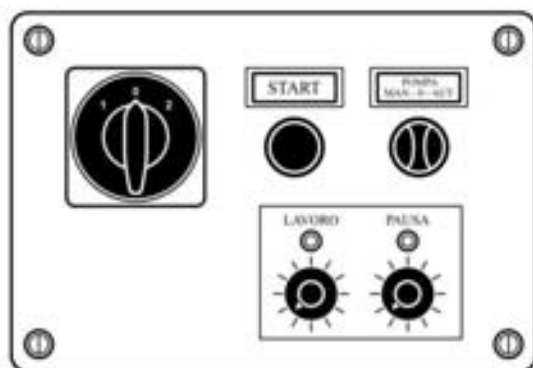

Impianto elettrico CE con temporizzatore con
2 selettori, 12 posizioni per pausa e lavoro e con
2 range di temporizzazioni disponibili (da specificare in
caso di ordine):
Tipo LIV 1: lavoro 2-24 minuti, pausa 10-120 minuti
Tipo LIV 2: lavoro 2-24 minuti, pausa 1-12 ore
CE control panel with 2 selector switch timer,
with 12 possible selections each and with
2 time rate options (to be stated in case of order):
Option 1: LIV 1 run 2-24 minutes, pause 10-120 minutes
Option 2: LIV 2 run 2-24 minutes, pause 1-12 hours

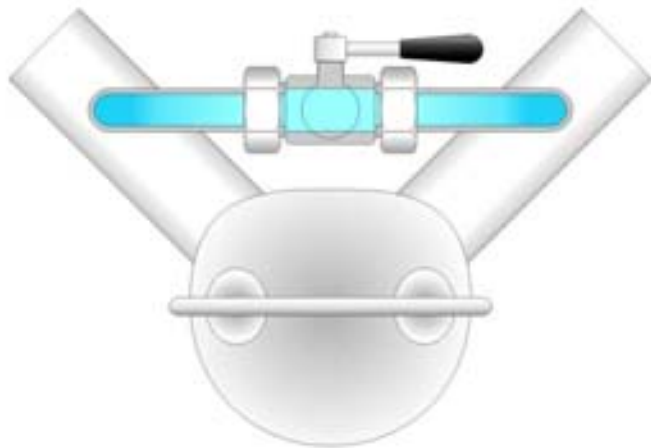

By-pass con valvola a sfera per i modelli: Mini, Minor, Major, Maxi.
Ball bypass valve for pump types: Mini, Minor, Major, Maxi.

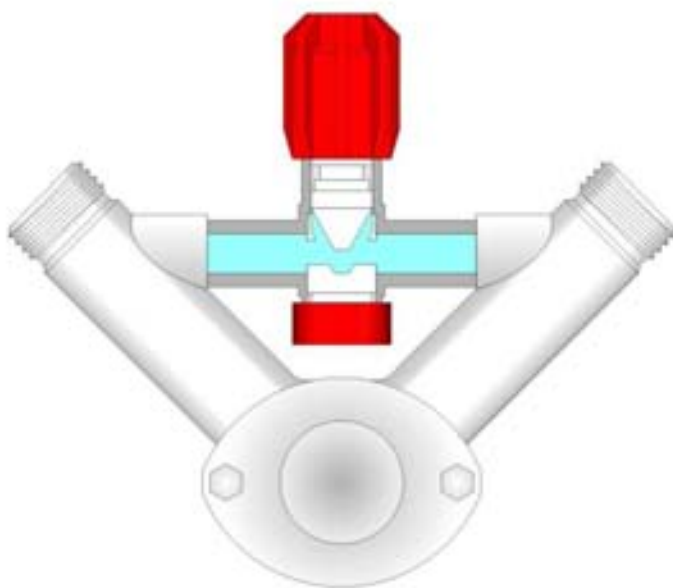

By-pass con valvola a molla per modello Midex.
Spring bypass valve for Midex pump types.

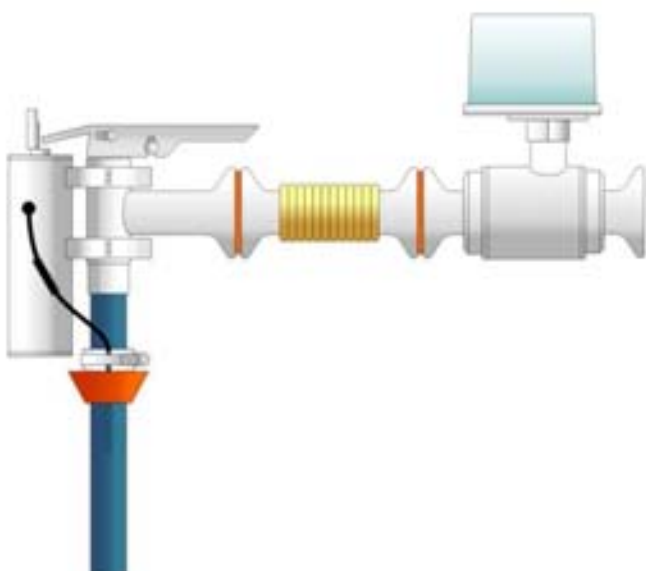

Kit riempi barriques o fusti.
Kit for barrel filling.

Pistola automatica inox con valvola di non ritorno e pressostato.
Stainless steel automatic gun with no return valve and pressure switch.

Il kit può essere utilizzato solo con quadro elettrico del tipo con derivazione supplementare 24V NC.
 In caso di pompa con inverter quest'ultimo deve essere dotato di derivazione supplementare NC.
The kit must be used only with a control panel with a supplementary 24V NC shunt trip.
In case of pump driven by frequency converter, the last must be fitted with a supplementary NC trip.

SPARE PARTS

Pos.			MINI	MIDEX	MINOR	MAJOR	MAXI
1	CULATTA ANTERIORE / FRONT COVER	INOX AISI 304 / STAINLESS STEEL AISI 304			x	x	x
		INOX AISI 316 / STAINLESS STEEL AISI 316	x	x			
2	ANELLO OR CULATTA / O RING COVER	GOMMA NBR / RUBBER (NBR)	x	x	x	x	x
3	CORPO POMPA / CASING	INOX AISI 304 / STAINLESS STEEL AISI 304			x	x	x
		INOX AISI 316 / STAINLESS STEEL AISI 316	x	x			
7	GIRANTE / IMPELLER	GOMMA NATURALE (NR) / NATURAL RUBBER (NR)	x	x	x	x	x
		NEOPRENE (CR) / NEOPRENE (CR)	x	x	x	x	x
		NITRILE (NBR) / NITRILE (NBR)	x	x	x	x	x
		EPDM / EPDM	x	x	x	x	x
8	CULATTA POSTERIORE / REAR COVER	INOX AISI 304 / STAINLESS STEEL AISI 304			x	x	x
		INOX AISI 316 / STAINLESS STEEL AISI 316	x	x			
9	TENUTA MECCANICA / MECHANICAL GASKET	INOX-GRAFITE-NBR / STAINLESS STEEL-GRAPHITE-NBR	x	x	x	x	x
		CARB. DI TUNGSTENO-NBR / TUNGSTEN CARBIDE-NBR	x	x	x	x	x
		CARB. DI TUNGSTENO-VITON / TUNGSTEN CARBIDE-VITON	x	x	x	x	x
10	SUPPORTO S/P / SUPPORT S/P	ALLUMINIO / ALUMINIUM			x	x	x
	SUPPORTO MID / SUPPORT MID	ALLUMINIO / ALUMINIUM			x	x	x
11	RONDELLA / WASHER	INOX AISI 304 / STAINLESS STEEL AISI 304			x	x	x
12	DADO / NUT	OTTONE CROMATO / CHROMATE BRASS			x	x	x
13	CUSCINETTO / BALL BEARING	COMMERCIALE / COMMERCIAL			x	x	x
14	ALBERO / SHAFT	INOX AISI 420 / STAINLESS STEEL AISI 420			x	x	x
15	CHIAVETTA / FLAT KEY	INOX AISI 304 / STAINLESS STEEL AISI 304			x	x	x
16	ANELLO SEEGER / SEEGER RING	ACCIAIO / STEEL			x	x	x
17	PULEGGIA / PULLEY	ALLUMINIO / ALUMINIUM			x	x	x
18	RONDELLA / WASHER	INOX AISI 304 / STAINLESS STEEL AISI 304			x	x	x
19	VITE / BOLT	INOX AISI 304 / STAINLESS STEEL AISI 304			x	x	x
20	ANELLO DI PROTEZIONE / GUARD RING	GOMMA NBR / RUBBER (NBR)	x		x	x	
21	CAVALLOTTO / U-BOLT	INOX AISI 304 / STAINLESS STEEL AISI 304			x	x	x
	VITE / BOLT	INOX AISI 304 / STAINLESS STEEL AISI 304	x	x			
22	CAVALLOTTO / U-BOLT	INOX AISI 304 / STAINLESS STEEL AISI 304					x
	ANELLO DISTANZIALE / SPACING RING	INOX AISI 304 / STAINLESS STEEL AISI 304		x	x	x	
23	ANELLO SEEGER / SEEGER RING	INOX AISI 304 / STAINLESS STEEL AISI 304		x	x	x	
	CUSCINETTO / BALL BEARING	COMMERCIALE / COMMERCIAL					x
24	CHIAVETTA / FLAT KEY	INOX AISI 304 / STAINLESS STEEL AISI 304	x				
25	FLANGIA MID / MID FLANGE	ALLUMINIO / ALUMINIUM			x	x	x
26	VITE / BOLT	ACCIAIO / STEEL			x	x	x
27	GIUNTO POMPA / PUMP COUPLING	ACCIAIO / STEEL			x	x	x
28	VITE / BOLT	ACCIAIO / STEEL			x	x	x
29	MANICOTTO DI COLL.TO / BOX COUPLING	NYLON / NYLON			x	x	x
30	GIUNTO MOTORE / MOTOR COUPLING	ACCIAIO / STEEL			x	x	x
31	MOTORE ORBITALE / ORBITAL MOTOR	COMMERCIALE / COMMERCIAL			x	x	x
32	ANELLO DI CENTRAGGIO / CENTER RING	INOX AISI 304 / STAINLESS STEEL AISI 304			x	x	x
33	CHIAVETTA / FLAT KEY	ACCIAIO / STEEL			x	x	x
34	RONDELLA / WASHER	INOX AISI 304 / STAINLESS STEEL AISI 304			x	x	x
35	VITE / BOLT	INOX AISI 304 / STAINLESS STEEL AISI 304			x	x	x

MINI

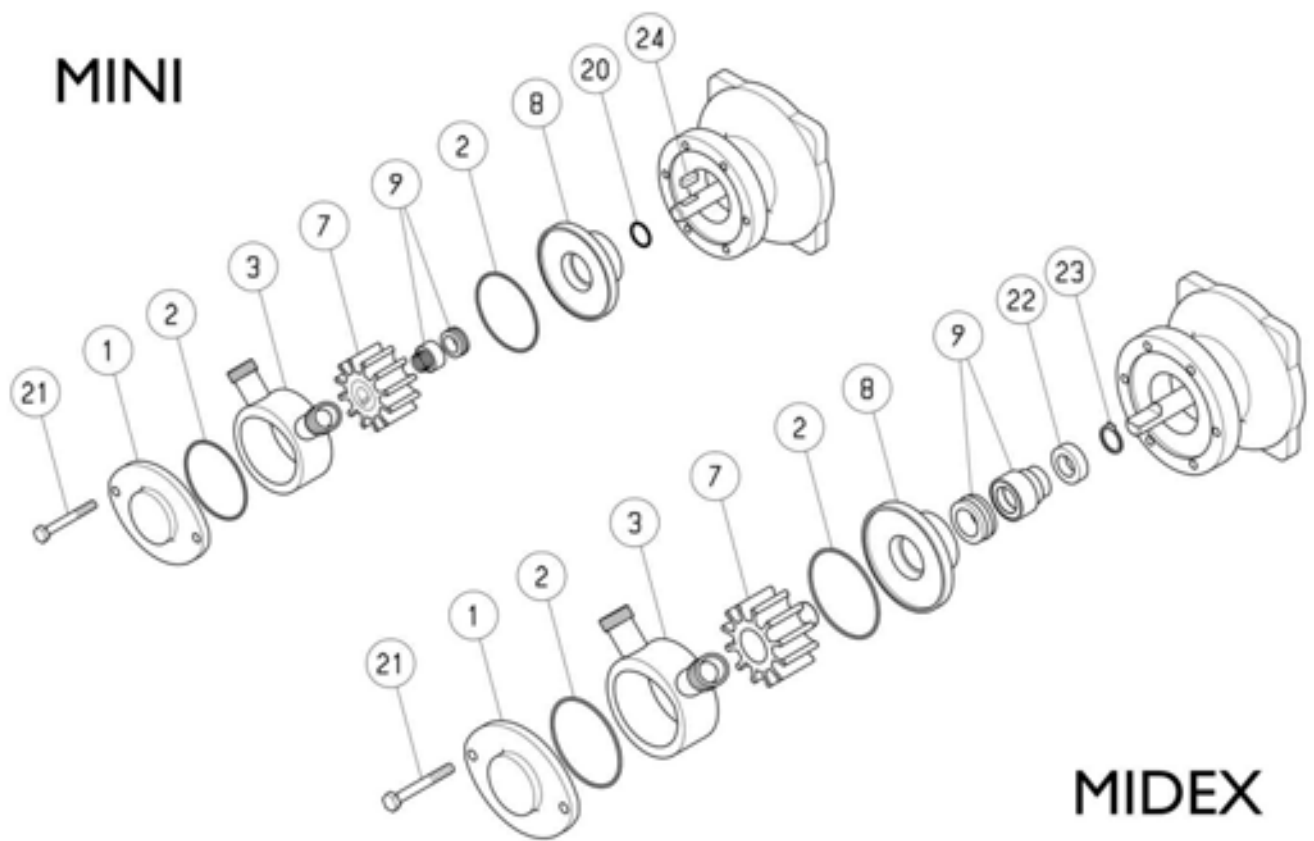

MIDEX

MINOR

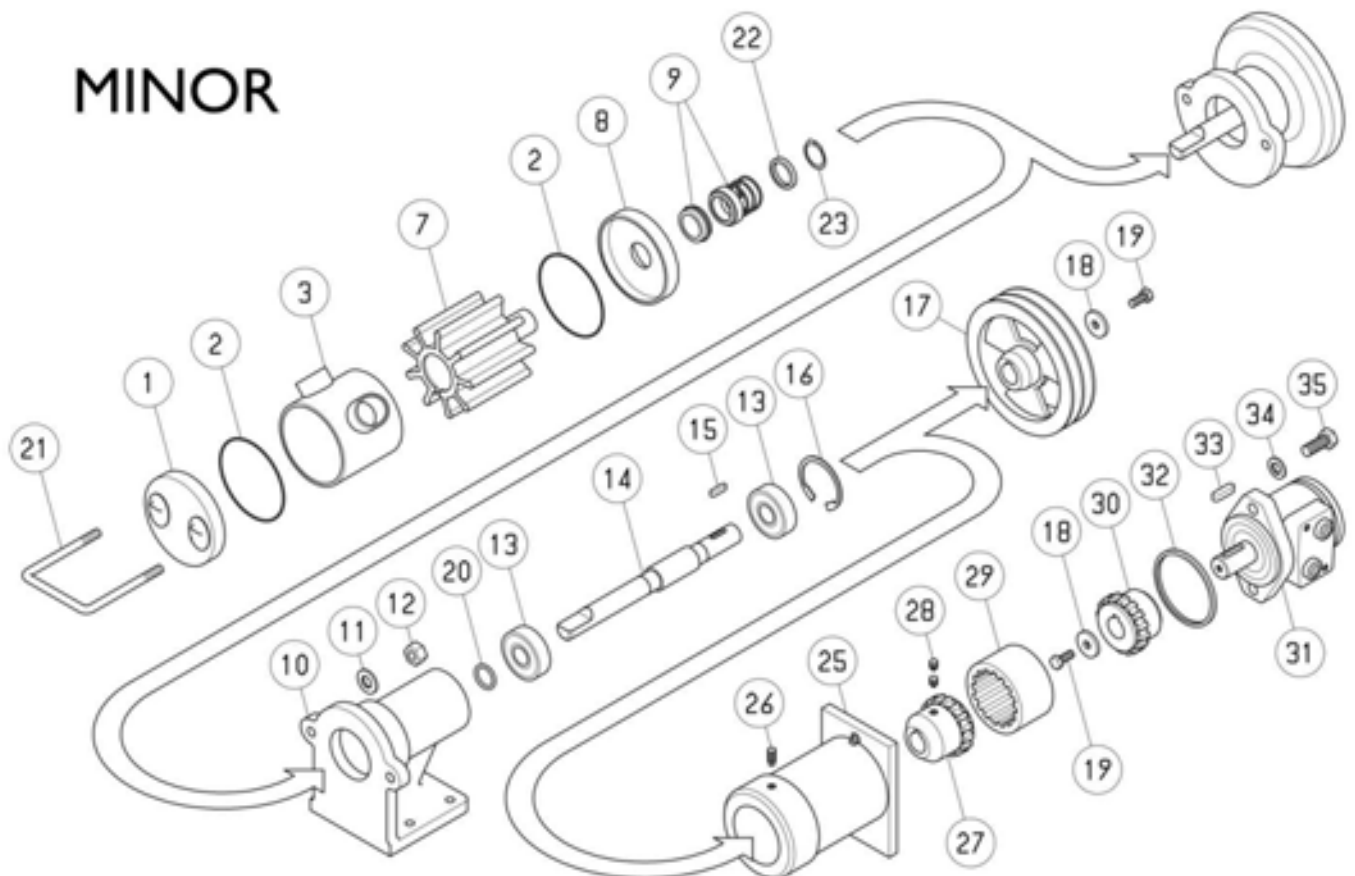

MAJOR

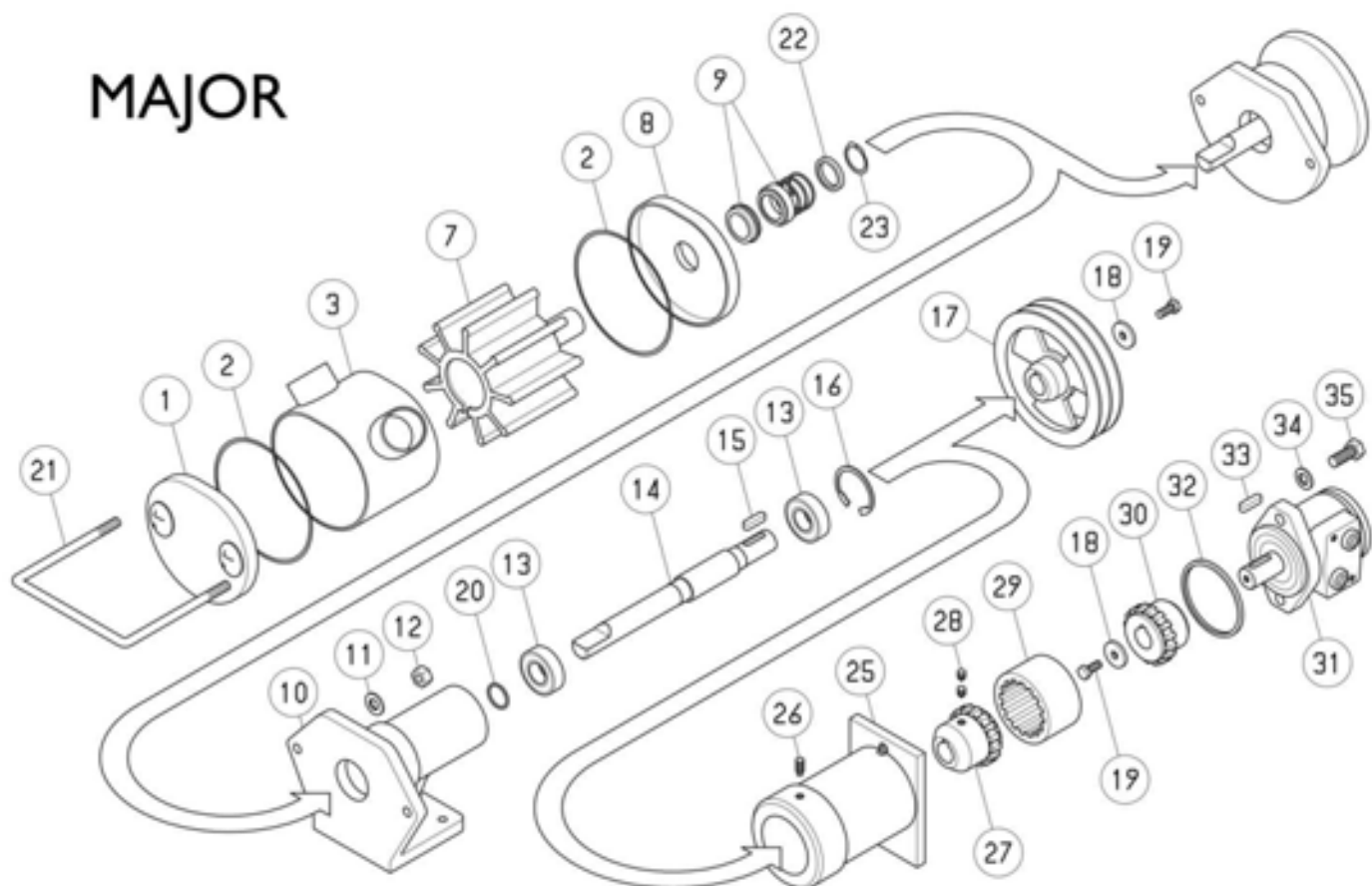

MAXI

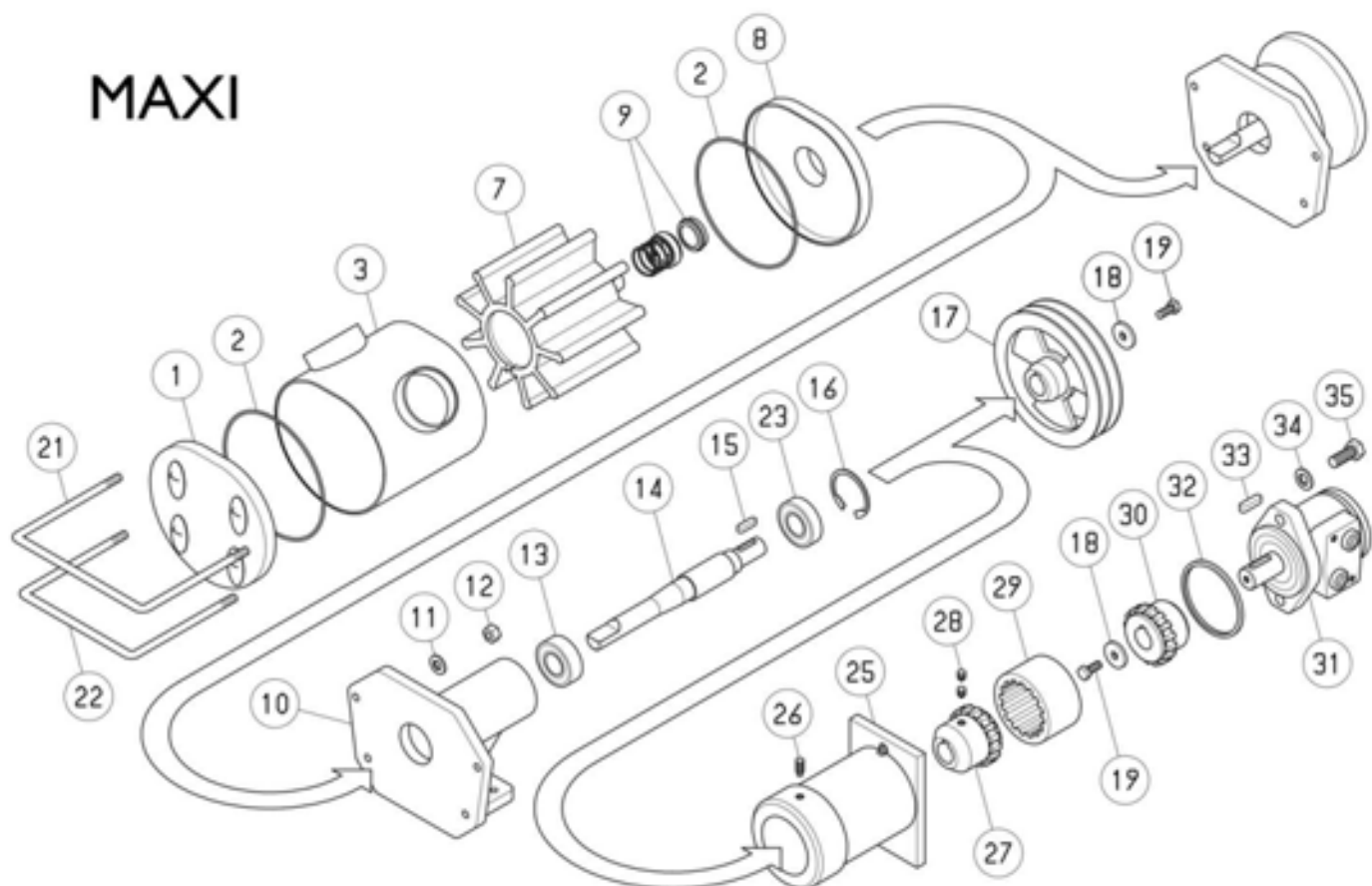



LIVERANI

FLUID TRANSFER TECHNOLOGY

Via De' Brozzi, 94 - 48022 Lugo (Ra) ITALY
Tel. ++39 0545 22379 - Fax ++39 0545 30350
E-mail: liverani@liverani.com
www.liverani.com

Distributore Distributor